



Camber

**Specialty
Products
Company®**

Caster

**TRADITIONAL
PERFORMANCE**

**RACING
MUSCLE**

**OFF-ROAD
HEAVY DUTY**

Toe

**Total Wheel
Alignment
SourceBook
2013-14 Full Line**

\$5.00 USD



Innovative Solutions/New Products

Look for our "New" logo throughout this Sourcebook for the latest in alignment technology. Over 30 new parts and tools have been added including:

Brake Drum Spacers	107
Chevy Camaro/Pontiac G8 Rear Cam	88
Chevy/GMC Caster/Camber Kit	83
Chrysler 200 Dodge Avenger Rear Arm	60
Colorado Front Adjustable Control Arms	57
Dodge Caster/Pinion Cams	82
Dodge/Jeep Front Camber/Caster Kit	81
Dodge/Jeep Rear Camber Arm	66
Dodge Pin Joint Adjusting Wrench	135
Ford/Mercury Bushing Adjusting Tool	134
GM Camber/Caster Tool	132
GM Rear Toe and Camber Shims	72
Honda 24mm Toe Adjusting Tool	134
Jeep Wrangler JK JounceShock™ System ...	120
Lexus IS & GS Adjustable Rear Arm	68

Muscle Car Coilover Mount/Spacer Plates	95
Nissan Altima Adjustable Rear Arm	76
Peterbilt Air Leaf Pinion Angle Shim	101
Pin Wrench Set	118
Racing Wide Mouth Adjustable Arm Plates ...	115
S Cam Bushing Extractor	110
SPC 'EZ On' Wheel Centering Sleeves	106
SPC 'EZ On' Wheel Centering Tool Set	105
Sprinter Van Front Adjuster Kit	57
Subaru/Scion Front Camber Adjuster	80
Subaru/Scion Adjustable Rear Arm	70
T-Bird, Mark VIII, Cougar Front Cam Kit	89
Toyota Cam Bolt Kit	56
Toyota Front Adjustable Control Arms	56
xAxis™ Sealed Flex Joint	116

A win/win

For almost a decade SPC Performance has partnered with Papadakis Racing. Joining Stephan when he was driving and building Honda S2000s running SPC's adjustable ball joints (page 64), SPC has been there throughout the amazing growth of Papadakis Racing. Today Stephan is one of the acknowledged leaders and innovators of drifting, winning worldwide with his Scion sponsored race team and attracting world-class drivers such as Tanner Foust and his current driver Fredric Aasbø. SPC Performance parts have been part of Stephan's winning teams, and SPC is continuing that partnership with Papadakis Racing and Aasbø's FR-S running our newest rear adjustable lower control arms and toe arms (page 70) along with EZ Cams™ (page 79) correcting front camber. By drifting these parts in Europe SPC has a perfect platform for high stress testing on these popular tuner parts. **Papadakis Racing and SPC - a winning combination!**

Scion Racing



Scion Racing



Larry Chen / Speedhunters



TOLL FREE
800-525-6505
www.specprod.com



SPC
PERFORMANCE.

Entire contents © 2013
Niwot Corporation,
dba
Specialty Products
Company®.



**TOOL
ICON**

When you see our "wrench"
next to a part it means there
is a special tool available to
assist you in the installation



**SPC-TV
& QR
ICON**

When you see a "TV" next
to a part it means there is an
installation video to help
you install the part at
www.SPC-TV.com
OR

Scan the QR Code with your
smart phone's Bar Code
App for videos and more
information

The design, shape,
format and
arrangement of
this catalog constitutes
a trademark of
Specialty Products
Company.
Printed in U.S.A.

All rights reserved,
reproduction in whole or in part
without permission is prohibited.
Total Wheel Alignment Sourcebook
is a trademark of
Niwot Corporation.

Table of Contents

INTRO/APPLICATIONS 2-46

Here is where you find our part and tools - a quick look-up for everything from a 2003 Honda Accord to a Peterbilt Truck.

Includes our Muscle Car Applications!

How to Use the Sourcebook	2
How to Sell Alignment	2
Training Resources	3
Explanation of Alignment	4-6
Passenger Car/Mini-Van/Truck & SUV Applications	7-45
Estimated Installation Times	46

PARTS 47-100

Find out more about the part you need. In this section you will find detailed information about our parts such as degree of change, install times, and helpful tech tips.

Inventory Control Boards	47-48
Alignment Parts	49-95
Muscle Car Parts	91-95
Coil Spring Spacers	96-100

HEAVY DUTY 101-111

We carry a complete line of alignment parts, tools and accessories for OTR vehicles. From Freightliners to Tandem Alignment systems, we have you covered.

Heavy Duty Truck Shims & Parts	101-104
Wheel Centering Products	105-107
Truck Gauges and Heavy Duty Truck Tools	108-111

RACING/OFF ROAD 112-121

SPC is the builder's choice for the best in suspension tuning - From adjustable, rugged upper control arms to our xAxis™ sealed flex joints and JounceShocks™, our component systems are the perfect fit to dial in your racing or off road suspension.

Customize your Arm	112
Pre-built Arms	113
Component Parts - Cross shafts, Adjusting Sleeves, Plates, More ..	114-115
Chassis Components - xAxis™, Rod Ends & Receivers, More ..	116-117
JounceShocks™ - Components and Complete Vehicle Systems ..	118-120
Racing Tools and Equipment	121

TOOLS 122-136

Find our innovative FasTrax™ Camber/Caster Gauge to specific camber/caster/toe tools that installers need to correctly install our parts in this section. We also carry an extensive line of wheel service tools, strut and ball joint tools, plus more!

ACCESSORIES 137-138

Alignment turntables, wheel stands, toe bars and more! This is the section that alignment technicians turn to for specialized equipment that makes their job easier and more profitable.

BRAKE & CV 139-142

We have a variety of consumables for the brake repair specialist. An extensive line of lathe inserts, drum tools, rotor silencers along with CV Boots and accessories.

Lathe Inserts/Drum Tools, and Rotor Silencers	139-140
Brake Tools, Radial Run-Out Gauges	141
CV Boots, Tools and Accessories	142

SPC GEAR & INDEXES 143-152

You can wear SPC - shirts, hats, gloves and more, along with banners and stickers for your shop or vehicle. With two indexes, numerical and alphabetical quickly find just what you need.

SPC Gear	143-145
Numerical Index/Retail Pricing	146-151
Alphabetical Index	152



www.specprod.com

Call for your nearest distributor, product info or
Technical Assistance • In the USA and Canada

1-800-525-6505

Applications
Parts
Heavy Duty
Racing/Off Road
Tools
Accessories
Brake & CV
Gear/Index

HOW TO USE

The Alignment Sourcebook™

This Sourcebook has been designed with you in mind. Each section has tabs that allow you to quickly flip to the section you need without having to look through the entire Sourcebook. But it is a good idea to review the entire Sourcebook to check out new products and solutions for all your alignment needs.

Each new product is marked with our "NEW" logo for instant identification (shown at right). These new products are on the cutting edge of alignment technology.

There are several ways to use this Sourcebook:

- 1** If you are looking for a specific part for a specific vehicle, check for the vehicle make and model in the Applications Section starting on page 7.
- 2** If you know the part number of the part you need, the numerical index starts on page 146. Look there first.
- 3** If you have an idea of the part name, but not the part number, then the alphabetical index on page 152 is your first stop.

At Specialty Products Company our goal is to assist you in every way to make car and truck alignment fast, accurate and profitable. We are committed to finding accurate, easily installed solutions to automotive driving and handling problems. Our products include excellent service and industry leading technical support.

THIS TOTAL WHEEL ALIGNMENT SOURCEBOOK™ WILL ASSIST YOU IN MAKING THE CORRECT RECOMMENDATIONS TO YOUR CUSTOMERS. THE SOURCEBOOK CONTAINS EVERYTHING NEEDED TO DETERMINE ESTIMATES AND RECOMMENDATIONS.



Our "NEW" logo throughout this Sourcebook highlights the latest in alignment technology.

SPC PERFORMANCE

SPC Performance is your source for alignment products that meet the specific needs of lowered and performance vehicles as well as popular muscle cars, street rods & racers.

For serious off-road enthusiasts, SPC Performance's JounceShock™ greatly improves vehicle mobility and handling.

HOW TO SELL

Proper Alignment

- 1** When a set of new tires are installed or suspension parts changed, discuss frequency and need for total wheel alignment. Explain unusual tire wear or handling problems.
- 2** To determine the type of alignment required, refer to the Application section (pages 7-45) in this Sourcebook. Also refer to this section for the correct selection of original equipment and aftermarket replacement parts available from Specialty Products.
- 3** Use your Sourcebook and a showroom tire to explain tire wearing and control angles.
- 4** Explain to the customer the benefits of 4 Wheel and Thrust Wheel Alignments:

- ✓ Prolong Tire Life
- ✓ Help Eliminate "Pulls"
- ✓ Improve Handling
- ✓ Increase Fuel Mileage
- ✓ Minimize Premature Wear of Suspension Parts

- 5** *Ask for the sale.* Your customer will appreciate the benefits.

THE PROPER WHEEL ALIGNMENT SAVES THE CUSTOMER MONEY AND INCREASES CUSTOMER SATISFACTION BY DOING THE JOB RIGHT THE FIRST TIME.



**TOOL
ICON**

When you see our "wrench" next to a part it means there is a special tool available to assist you in the installation

**SPC-TV
& QR
ICON**



When you see a "TV" next to a part it means there is an installation video to help you install the part at

www.SPC-TV.com

OR

Scan the QR Code with your smart phone's Bar Code App for videos and more information

Check our Website at www.specprod.com to get our class schedules and fees for 2013 and 2014

OR

Call for class availability, future schedules and more **800-525-6505**



Want more?

We have videos on everything from installing our newest 370Z arms to learning more about alignment angles at www.SPC-TV.com

And you can earn great prizes by watching the videos.

You earn points that can be redeemed for SPC Gear. Log on to find out more!



Keep up to date with what's new and follow Specialty Products on



Facebook



Twitter



YouTube

Basic Hands On Alignment Class

This four day Basic course is designed for the entry-level Technician with less than one year of hands-on alignment experience. The course consists of presentations and demonstrations with 60% classroom and 40% hands-on instruction. There will be a pre-test on the first day that will enable us to focus on where you need individual attention. Tests are given each morning that allows us to track your progress.

- Describe basic alignment angles and why they are needed on the vehicle.
- Describe front and rear suspension types and how to properly inspect them.
- Explain why total alignment and thrust alignment are needed.
- Demonstrate proper use of the alignment specification manual.
- Perform proper wheel alignment procedures for front wheel and rear wheel drive vehicles along with light trucks.
- Perform proper installation of aftermarket alignment aids.

Advanced Hands On Alignment Class

This four day Advanced course is designed for the Technician that has been working in the trade for a period of at least two years. The course consists of presentations and demonstrations with 50% classroom and 50% hands-on instruction. There will be a pre-test on the first day that will enable us to focus on where you need individual attention. Tests are given each morning that allows us to track your progress

- Describe front and rear suspension types and how to properly inspect them.
- Explain why total alignment and thrust alignment are needed.
- Describe more advanced alignment angles such as Turning Radius, Setback, Bump Steer, Steering Axis Inclination, Included Angle and Scrub Radius and how they can be used to help diagnose alignment and suspension problems.
- Explain to the customer how these advanced alignment angles affect the handling and performance of the vehicle.
- Demonstrate the proper procedure for measuring basic and advanced alignment angles.
- Perform proper installation of Ford truck sleeves and understand how to achieve the correct adjustment the first time.
- Perform proper installation of aftermarket alignment aids.
- Explain the issues involved and describe how to properly adjust lowered and lifted vehicles.

Field Clinics

Our three hour Field Clinics will provide you with reliable information to enable you to diagnose and align any vehicle correctly the first time. SPC's professional ASE trainers provide specific alignment and suspension information on new model vehicles. Topics include; adjustment methods, problems associated with suspension and alignment, technical service bulletins, and service procedures. See your WD for a clinic near you, or call Specialty Products Toll-Free at 800-525-6505.

Online Training

If you want to stay competitive in today's high-tech automotive aftermarket Specialty Products Company now has both Basic and Advanced courses available online at www.specprod.com. This training course was developed by our ASE Master Certified technicians.

You can now get comprehensive training in the changing alignment field on your schedule. Available in 2 modules, this training will take you from basic alignment angle descriptions, to vehicle specific applications that you see weekly in your shop.



Go To www.specprod.com

Training Aids 85560

ASE TEST PREP. BOOK FOR SUSPENSION AND STEERING

This book contains information on test taking strategies, task lists and overviews, sample test questions, ASE-style exams along with explanations to the answers. (Delmar Test A4 2nd Ed.)



www.specprod.com

Call for your nearest distributor, product info or Technical Assistance • In the USA and Canada

1-800-525-6505

ALIGNMENT TERMS

Caster

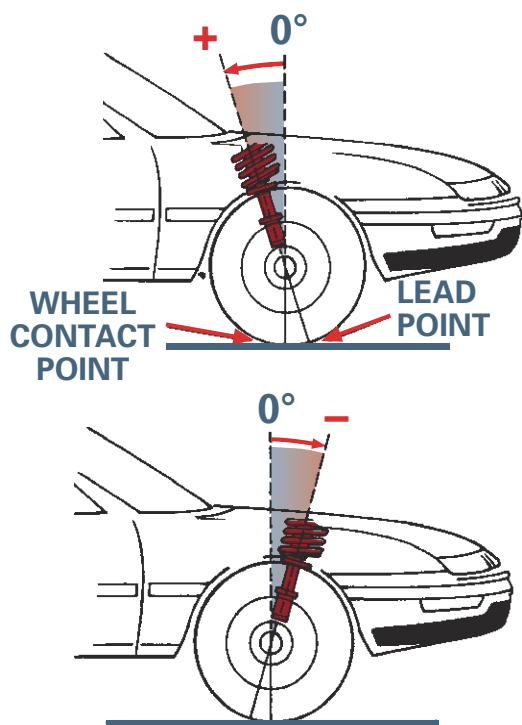

DEFINITION: The forward or backward tilt of the upper ball joint, or top of the strut, relative to the lower ball joint.

PURPOSE: Caster affects steering stability and steering wheel returnability.

METHODS OF CASTER ADJUSTMENT: (1) Shims (2) Cams (3) Slotted Frame (4) Strut Rod (5) Strut Rotation (6) Cradle Movement (7) Offset Ball Joint (8) Sliding Ball Joint

0 CASTER: The upper ball joint or top strut bearing and lower ball joint are in the same plane as viewed from the side of the vehicle.

POSITIVE CASTER: The upper ball joint or top strut bearing is toward the rear of the vehicle in relation to the lower ball joint as viewed from the side of the vehicle.

NEGATIVE CASTER: The upper ball joint or top strut bearing is toward the front of the vehicle in relation to the lower ball joint as viewed from the side of the vehicle.

SYMPTOMS OF NEG. CASTER: (1) Steering wheel shows lack of "returnability" after a turn. (2) Steering is touchy at high speed (wander and weave).

Effect: Vehicle pulls to the side with the Lowest Caster.

Example: Left front set at 1/2° positive Caster, right front set at 1-1/2° positive Caster. This vehicle will pull to the left.

Camber

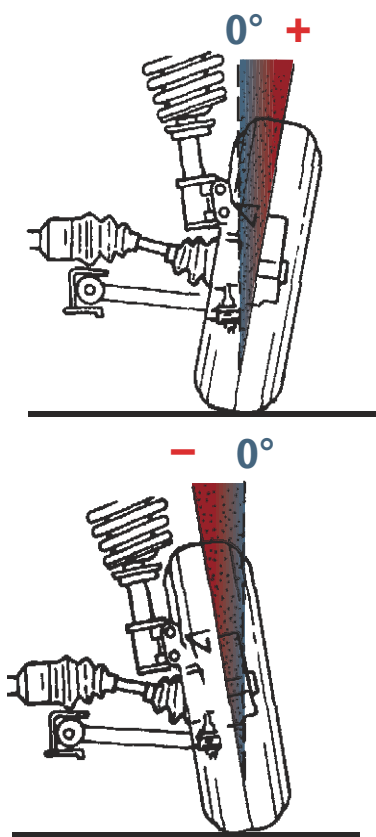

DEFINITION: Inward or outward tilt of the top of the wheel.

PURPOSE: Adjustment centers the vehicle's load on the tire, eliminating pull. Proper adjustment reduces camber tire wear and pulling.

METHODS OF CAMBER ADJUSTMENT: (1) Shim (2) Cams (3) Slotted Frame (4) Strut Rotation (5) Wedges (6) Ball Joint Rotation (7) Offset Bearing Plates (8) Cam Bolts (9) Eccentrics (10) Offset Ball Joints (Offset Bushings)

0 CAMBER: When wheel and tire assembly are in exact vertical position.

POSITIVE CAMBER: When the top of the wheel and tire assembly is tilted out, or away from the engine.

TOO MUCH POS. CAMBER CAUSES: (1) Wear on the outside of the tire. (2) Extra wear on the suspension parts with positive camber. (3) The vehicle will pull to the side with the **most positive** camber.

NEGATIVE CAMBER: The top of the wheel and tire assembly is tilted in, toward the engine.

TOO MUCH NEG. CAMBER CAUSES: (1) Wear on the inside portion of the tire. (2) Extra wear on the suspension parts with negative camber (3) The vehicle will pull to the side with the **most positive** camber.

UNEQUAL CAMBER From side to side causes: (1) Vehicle to pull to the side with the more positive camber.

Example: Left front set at 1° positive. Right front set at 1/2°. This vehicle may pull left.

Setback

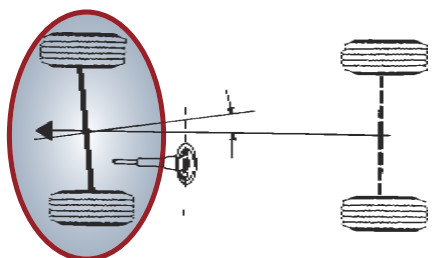

DEFINITION: One wheel set back further than the other.

SETBACK IS CAUSED BY: (1) Manufacture. (Sometimes they build them this way). (2) Collision.

Normally up to .5" Setback will cause no problems other than steering wheel misalignment when using some types of alignment equipment.

DEFINITION:	The difference between leading edges and trailing edges of the front of the wheel & tire assembly, measured at spindle height.
PURPOSE:	Minimize tire wear and rolling friction.
FRONT TOE ADJUSTMENTS:	(1) Tie Rod Adjusters
REAR TOE:	(1) Manufacturer's built-in adjuster (2) Cams (3) Cam bolts (4) Slots (5) Eccentrics (Offset Bushings) (6) Shims (7) EZ Arms XR™
0 TOE:	Distances across the front and trailing edges of the wheel and tire assemblies are equal.
TOE IN (+):	Distance across the front edges of the wheel and tire assemblies is less than across the trailing edges.
TOO MUCH TOE IN CAUSES:	(1) Rapid wear on outside edge of tire. (a) On radial tires too much Toe In resembles pos. camber wear. (b) Wear patterns are saw-toothed or scuffed . (c) Feeling sharp edges when rubbing your hand across the tire tread, from inside toward outside , reveals excessive Toe In . (2) Steering instability (extreme). (a) Wander (b) Shimmy
TOE OUT (-):	Distance across the front edges of the wheel and tire assemblies is wider than the trailing edges.
TOO MUCH TOE OUT CAUSES:	(1) Rapid tire wear-inside edge of tire. (a) On radial tires too much Toe Out resembles neg. Camber wear. (b) Wear pattern is saw-toothed or scuffing . (c) Feeling sharp edges when rubbing your hand across the tire tread, from outside to inside, reveals excessive Toe Out . (2) Steering instability (extreme). (a) Wander (b) Shimmy

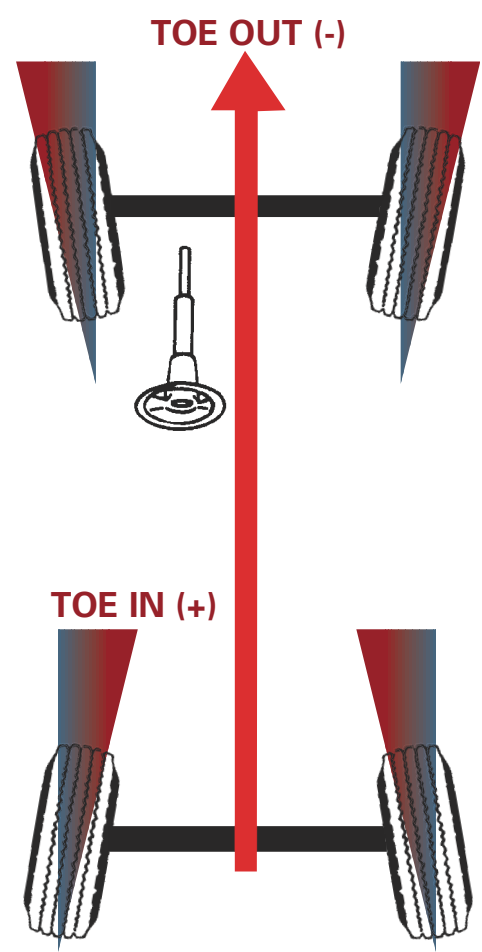

DEFINITION:	The relative position of the front wheels during a turn.
REFERRED TO AS:	(1) Toe out on turns (2) Turning radius
PURPOSE:	To prevent tire side slip. To prevent excessive tire wear. To prevent tire squeal on turns.
DIAGNOSE FOR BENT PARTS:	If readings differ more than 1-1/2° from specifications on most vehicles, and the tires squeal when cornering, the vehicle may have a bent steering arm. Most Turning Angles are non-adjustable angles but can be corrected by replacing bent parts.

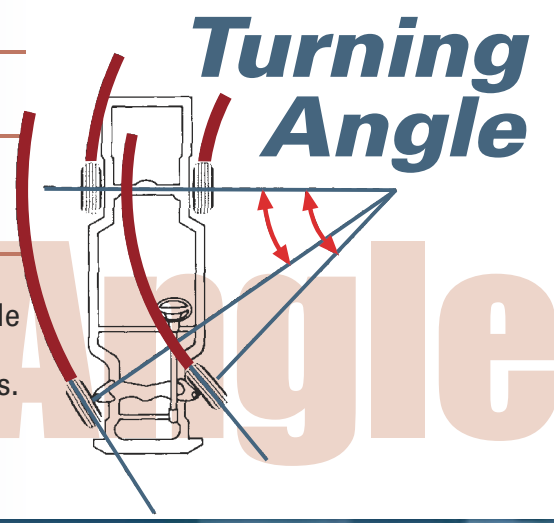

DEFINITION:	The direction the rear wheels are positioned in reference to the vehicle centerline.
REAR WHEEL THRUST WILL CAUSE:	(1) Tire wear (2) Steering wheel misalignment (3) Car pulls (4) "Dog Tracking" (5) Crooked steering wheel
THRUST CAN BE CORRECTED BY:	(1) Adjustment of built in toe adjuster. (2) Installing tapered shims between spindle and hub. (3) Cams or other aftermarket adjusters. (4) Specialty Products Thrust Plate (#63020, #63030 Kits - page 57).

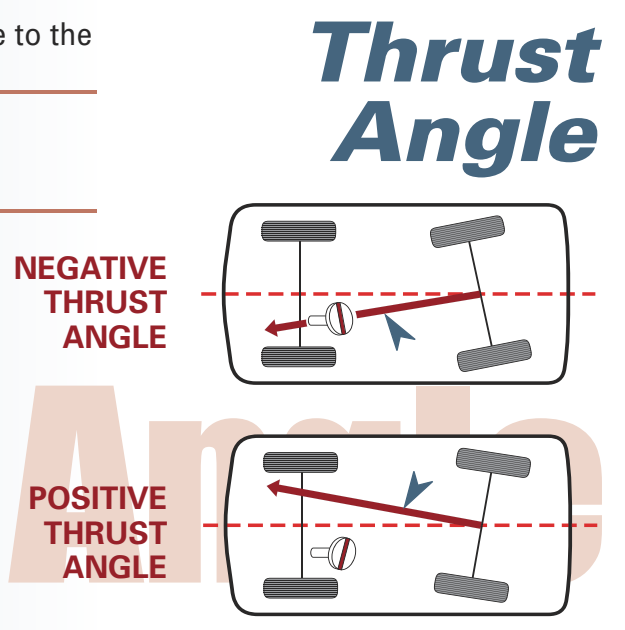

S.A.I.

I.A.

Scrub Radius

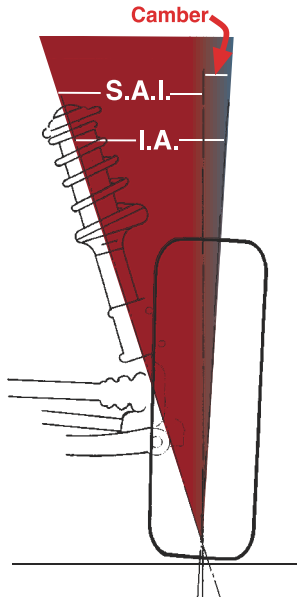

DEFINITION OF S.A.I. (Steering Axis Inclination):

The angle between a true vertical line starting at the center of the tire at the road contact point and a line drawn through the center of the strut (or upper ball joint) and lower ball joint. S.A.I. is a non-adjustable angle on most vehicles. OR...

The angle formed by the intersection of a line drawn through the upper and lower suspension mounting points (as viewed from the front of the vehicle) and true vertical.

NOTE: A bent lower control arm can also change S.A.I. The strut suspension on a unibody vehicle has many variables and locating the damaged part may be difficult.

DEFINITION OF I.A. (Included Angle):

S.A.I. angle plus actual camber (positive) or minus actual camber (negative) is the included angle. When camber is positive, add it to the S.A.I. angle. If camber is negative, subtract it from the S.A.I. angle. This angle is used as a diagnostic tool to determine if structural misalignment is present or suspension parts are bent.

DEFINITION OF SCRUB RADIUS:

When compared at ground level, the distance between the S.A.I. line (drawn through the steering pivots) and the centerline of the tire tread is called the Scrub Radius. When this line is toward the inside of the tread, the vehicle is said to have Positive Scrub Radius. When the line is toward the outside of the tire tread, the vehicle is said to have Negative Scrub Radius.

NOTE: Negative Scrub Radius will be found on FWD MacPherson Strut vehicles.

PURPOSE:

Directional Control Stability. • Steering Wheel Returnability. • Vehicle Load Placement.

S.A.I., I.A. and Camber can be used to locate areas of the strut system on unibodies which may have damaged or misaligned parts. I.A. (Included Angle) is used to determine if there is a damaged spindle or strut tube. The S.A.I. (Steering Axis Inclination) is used to determine if the unibody is misaligned.

S.A.I. Diagnostic Guide

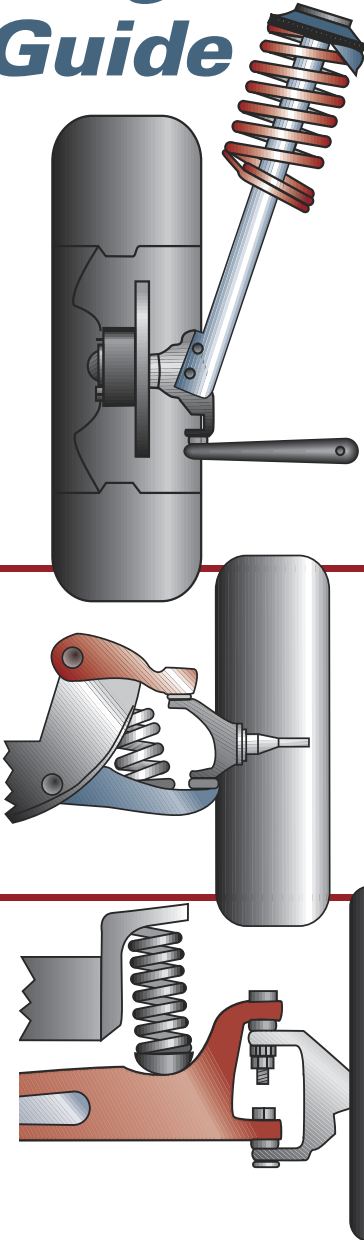

MACPHERSON STRUT SUSPENSIONS

SAI	CAMBER	INC. ANGLE	PROBABLE PROBLEM AREA
Within Spec	Less than Spec	Less than Spec	Bent Spindle Assembly and/or Bent Strut.
Within Spec	Greater than Spec	Greater than Spec	Bent Spindle Assembly and/or Bent Strut.
Less than Spec	Greater than Spec	Within Spec	Bent Control Arm, or Top of Strut Tower Pushed Outward, or Mis-Aligned Engine Cradle.
Greater than Spec	Less than Spec	Within Spec	Top of Strut Tower Pushed In, or Engine Cradle Mis-Aligned.
Less than Spec	Greater than Spec	Greater than Spec	Bent Control Arm, or Top of Strut Tower Pushed Out PLUS Bent Spindle Assembly and/or Bent Strut.
Less than Spec	Greater than Spec	Less than Spec	Bent Control Arm, or Top of Strut Tower Pushed Out PLUS Bent Spindle Assembly and/or Bent Strut.
Less than Spec	Less than Spec	Less than Spec	Bent Control Arm, or Top of Strut Tower Pushed Out PLUS Bent Spindle Assembly

SHORT/LONG ARM SUSPENSIONS

SAI	CAMBER	INC. ANGLE	PROBABLE PROBLEM AREA
Within Spec	Less than Spec	Less than Spec	Bent Spindle Assembly
Less than Spec	Greater than Spec	Within Spec	Bent Lower Control Arm or Bent Frame
Greater than Spec	Less than Spec	Within Spec	Bent Upper Control Arm or Bent Frame
Less than Spec	Greater than Spec	Greater than Spec	Bent Lower Control Arm, or Bent Spindle and/or Bent Strut.

FORD TWIN "I-BEAM" SUSPENSIONS

SAI	CAMBER	INC. ANGLE	PROBABLE PROBLEM AREA
Within Spec	Greater than Spec	Greater than Spec	Bent Spindle Assembly
Greater than Spec	Less than Spec	Within Spec	Bent "I" Beam
Less than Spec	Greater than Spec	Within Spec	Bent "I" Beam
Less than Spec	Greater than Spec	Greater than Spec	Bent "I" Beam & Bent Spindle Assembly

CAR/MINI-VAN/SUV/TRUCK APPLICATIONS

ACURA			REAR			FRONT			
Model/Body Style	Year	Drive Type	CAMBER/TOOL	TOE/TOOL	Page	Thrust Plate	CASTER/TOOL	CAMBER/TOOL	Page
CL <i>67075 Repl. Front Ball Joint-Pg. 62</i>	01-04	FWD	67090	OEMA	62		N/A	67125/40920 67320(8)/40920	63/125 65/125
CL <i>With 33.5mm Front Ball Joint Dia.</i>	96-99	FWD	67065 67265(8)	OEMA	61 64		84690,84695	67145/40920 67340(8)/40920	83,63/125 65/125
CL <i>With 35.3mm Front Ball Joint Dia.</i>	96-99	FWD	67065 67265(8)	OEMA	61 64		84690,84695	67125/40920 67320(8)/40920	83,63/125 65/125
CSX	06-10	FWD	67470 67465/75980,72509	OEMA	67 67/113,129		N/A	81260	79
EL	03-05	FWD	67230 69300 (Lower Arm)/ 69330(14)	OEMA	64 71 128		N/A	81280	79
EL	01-02	FWD	67230 69300 (Lower Arm)/ 69330(14)	OEMA	64 71 128		N/A	81260	79
EL <i>67245 Repl. Front Ball Joint-Pg. 64</i>	96-00	FWD	67030 69100 (Lower Arm)	OEMA 69250 69450	61 71,71 71		62010	62010 67135/40920 67330(8)/40920	59,59 63/125 65/125
ILX	13-14	FWD	67470 67465/75980,72509	N/A/87560	134 67/113,129		N/A	81290	79
Integra <i>65100 - Rear Trailing Arm Bushing Extractor - Page 127</i>	94-01	FWD	67030 69200 (except Type R) (Lower Arm)	OEMA 69250 69450	61 71,71 71		N/A	67135/40920 67330(8)/40920	63/125 65/125
Integra	90-93	FWD	67030 69200 (Lower Arm)	OEMA 69250 69450	71 71,71 71		N/A	67135/40920 67330(8)/40920	63/125 65/125
Integra	86-89	FWD	N/A	N/A			N/A	N/A	
Legend	91-96	FWD	N/A	OEMA			N/A	67135/40920 67330(8)/40920	63/125 65/125
Legend	86-90	FWD	N/A	OEMA			OEMA	N/A	
MD-X w/ Air Susp	07-13	AWD	N/A	OEMA			N/A	81290	79
MD-X w/o Air Susp	07-13	AWD	67570	OEMA	67		N/A	81290	79
MD-X	01-06	AWD	67290	OEMA	65		N/A	81280	79
NSX	91-06	RWD	OEMA	OEMA			OEMA	OEMA	
RDX	07-13	AWD	N/A	OEMA			N/A	81280	79
RL	05-13	AWD	N/A	OEMA			N/A	OEMA	
RL	96-04	FWD	67090	OEMA	62		N/A	67135/40920 67330(8)/40920	63/125 65/125
RSX	02-07	FWD	67230 69400 (Lower Arm)/ 69330(14)	OEMA	64 71 128		N/A	81280	79
RSX S-Type <i>start VIN2C003184</i>	02-07	FWD	67230 69400 (Lower Arm)/ 69330(14)	OEMA	64 71 128		N/A	81280	79
RSX S-Type <i>VIN2C003183 end</i>	02-02	FWD	67230 69400 (Lower Arm)/ 69330(14)	OEMA	64 71 128		N/A	81260	79
SLX	96-00	RWD	N/A	N/A			OEMA(5)	OEMA(5)	
TL (Inc. SH-AWD)	09-13	FWD/AWD	67540 67545(12)	OEMA 67540 67550 67555	68 68,68 68 68		N/A	67135/40920 67330(8)/40920	63/125 65/125
TL (Inc. Type S) <i>67075 Repl. Front Ball Joint-Pg. 62</i>	04-08	FWD	67095	OEMA	62		N/A	67125/40920 67320(8)/40920	63/125 65/125
TL (Inc. Type S) <i>67075 Repl. Front Ball Joint-Pg. 62</i>	99-03	FWD	67090	OEMA	62		84690, 84695	67125/40920 67320(8)/40920	83,63/125 65/125
TL 2.5 (Inc. Type S) <i>67075 Repl. Front Ball Joint-Pg. 62</i>	96-98	FWD	67065 67265(8)	OEMA	61 64		84690, 84695	67125/40920 67320(8)/40920	83,63/125 65/125
TL 3.2 (Inc. Type S) <i>67075 Repl. Front Ball Joint-Pg. 62</i>	96-98	FWD	67065 67265(8)	OEMA	61 64		84690, 84695	67135/40920 67330(8)/40920	83,63/125 65/125

ALIGNMENT FOOTNOTES BOLD PART NUMBER INDICATES PREFERRED CORRECTION METHOD

- (1) = CAUTION: Check for caliper to rotor clearance with disc brakes. Use spacer set 75970 (pg. 78) as necessary to keep caliper centered on rotor • (2) = All EXCEPT RWD 1500
 (3) = Honda S2000 Ball Joint - Rear Application - Only for 17" rims or larger • (4) = Check Bolt Length BEFORE Cutting Hole • (5) = Shims (pg. 58)
 (6) = LH Tie Rod Adjusting Sleeve Replacement (pg. 53) • (7) = Bolts, 73415, are necessary for changes greater than 3/4" (pg. 77) • (8) = Recommended for vehicles lowered more than 1.5"
 (9) = Will not work on 1988-89 models with welded-in ball joint • (10) = M3 Only, caster will decrease by 2 degrees • (11) = Pinion Angle Adj. Part No. 82370 (pg. 81)
 (12) = Limited camber range of ±1.0° • (13) = Center stock camber and toe adjusters before calculating shim change • (14) = 69330 included w/69300 or 69400 • (15) = Not for use w/disc brake
 ■ = Thrust Alignment Plate can correct thrust angle and setback (pg. 59) / Check frame angle with Angle Gauge Part No. 64225 (pg. 127)
 N/A = No Available Adjuster • OEMA = Original Equipment Manufacturer Adjustment • (*) = Series P/N, for correct size • SW = Station Wagon

©2013 Niwot Corp. dba Specialty Products Co.®

All products from Specialty Products Company are intended for use by professional installers only.



www.specprod.com

Call for your nearest distributor, product info or
Technical Assistance • In the USA and Canada

1-800-525-6505

Applications

Parts

Heavy Duty

Racing/Off Road

Tools

Accessories

Brake & CV

Gear/Index

Applications

CAR/MINI-VAN/SUV/TRUCK APPLICATIONS

ACURA-cont.

Model/Body Style	Year	Drive Type	REAR CAMBER/TOOL	TOE/TOOL	Page	Thrust Plate	FRONT CASTER/TOOL	CAMBER/TOOL	Page
TSX <i>67550 or 67555 must be used with 67540</i>	09-13	FWD	67540 67545(12)	OEMA 67540 67550 67555	68 68,68 68 68		N/A	67135/40920 67330(8)/40920	63/125 65/125
TSX <i>67075 Repl. Front Ball Joint-Pg. 62</i>	04-08	FWD	67290	OEMA	65		N/A	67125/40920 67320(8)/40920	63/125 65/125
Vigor <i>67075 Repl. Rear Ball Joint-Pg. 62</i>	92-94	FWD	67065 67265(8)	OEMA	61 64		84690, 84695	67165/40920 67360(8)/40920	83,63/125 65/125
ZDX	10-13	AWD	67570	OEMA	69		N/A	81290	79

AMC

Concord	80-83	RWD	N/A	N/A			OEMA	OEMA	
Eagle	80-87	AWD	N/A	N/A			OEMA	OEMA	
Spirit	80-83	RWD	N/A	N/A			OEMA	OEMA	

AUDI

80, 90 Quattro	88-96	AWD	OEMA	OEMA			N/A	OEMA	
80, 90	88-93	FWD	N/A	N/A			N/A	OEMA	
100	87-96	FWD	N/A	N/A			N/A	OEMA	
100 Quattro	87-96	AWD	OEMA	OEMA			N/A	OEMA	
100	70-77	FWD	75400(1)	75400(1)	78,78		N/A	OEMA	
200	87-96	FWD	N/A	N/A			N/A	OEMA	
200 Quattro	87-96	AWD	OEMA	OEMA			N/A	OEMA	
4000	80-87	FWD	75200(1)+10408	75200(1)+10408	78,49		N/A	OEMA	
4000 Quattro	80-87	AWD	OEMA	OEMA			N/A	OEMA	
5000 Quattro	86-88	AWD	OEMA	OEMA			N/A	OEMA	
5000	80-86	FWD	75400(1)+10408	75400(1)+10408	78,49		N/A	OEMA	
A3	06-13	FWD	OEMA	OEMA			N/A	N/A	
A4, RS4, S4	09-13	FWD/AWD	OEMA	OEMA			81360	81360	80,80
A4, RS4, S4	98-08	FWD/AWD	OEMA	OEMA			81350	81350	80,80
A4 Quattro	98-01	FWD/AWD	OEMA	OEMA			81350	81350	80,80
A4	96-97	FWD/AWD	N/A	OEMA			N/A	N/A	
A5, S5	09-13	FWD/AWD	OEMA	OEMA			81360	81360	80,80
A5, S5	07-08	FWD	OEMA	OEMA			81350	81350	80,80
A6, Quatro, RS6, S6	05-13	FWD/AWD	OEMA	OEMA			N/A	N/A	
A6, Quatro, RS6, S6	98-04	FWD/AWD	N/A	N/A			81350	81350	80,80
A7, S7	10-13	FWD/AWD	OEMA	OEMA			81360	81360	80,80
A8, S8	96-13	FWD	OEMA	OEMA			N/A	N/A	
Cabriolet	94-98	FWD	N/A	N/A			N/A	OEMA 81260	79
Fox	75-79	FWD	75200(1)+10408	75200(1)+10408	78,49		N/A	OEMA	
Q5	09-13	FWD	OEMA	OEMA			81360	81360	80,80
Q7	07-13	AWD	OEMA	OEMA			OEMA	OEMA	
Quattro	82-86	AWD	OEMA	OEMA			N/A	OEMA	
SQ5	13-13	AWD	OEMA	OEMA			81360	81360	80,80
TT	07-13	FWD	OEMA	OEMA			N/A	N/A	
TT Quattro	00-06	AWD	N/A	OEMA			81340	81340	80,80
TT	00-06	FWD	71530*/87530	71520*/87530	72/134		81340	81340	80,80

BMW

Vehicles w/ 14mm bolt	63-88	RWD	N/A	N/A			N/A	83115/73010(4)	82/129
Vehicles w/ 12mm bolt	63-88	RWD	N/A	N/A			N/A	N/A	
1 Series (F20)	11-13	RWD/AWD	N/A	N/A			N/A	N/A	
1 Series (E81, E82, E87, E88)	08-11	AWD	OEMA	OEMA			72070/72095	OEMA 72070/72095	74/129 74/129
1 Series (E81, E82, E87, E88)	08-11	RWD	OEMA	OEMA			72190/72095	OEMA 72190/72095	75/129 75/129
3 Series (F30)	12-13	RWD/AWD	OEMA	OEMA			N/A	OEMA	
3 Series (F31)	12-13	RWD/AWD	N/A	N/A			N/A	N/A	
3 Series Z4 (E89)	09-13	RWD	OEMA	OEMA			N/A	N/A	
3 Series Cpe. and Conv. (E92, 93)	07-12	AWD	OEMA	OEMA			72070/72095	OEMA 72070/72095	74/129 74/129
3 Series Cpe. and Conv. (E92, 93)	07-12	RWD	OEMA	OEMA			72190/72095	OEMA 72190/72095	75/129 75/129
3 Series M3 (E90)	07-12	RWD	OEMA	OEMA			N/A	OEMA	

CAR/MINI-VAN/SUV/TRUCK APPLICATIONS

BMW-cont.			REAR			FRONT			
Model/Body Style	Year	Drive Type	CAMBER/TOOL	TOE/TOOL	Page	Thrust Plate	CASTER/TOOL	CAMBER/TOOL	Page
3 Series Sedan and Wagon (E90, 91)	06-12	AWD	OEMA	OEMA			72070/ 72095	OEMA 72070/ 72095	74/ 129 74/ 129
3 Series Sedan and Wagon (E90, 91)	06-12	RWD	OEMA	OEMA			72190/ 72095	OEMA 72190/ 72095	75/ 129 75/ 129
3 Series Cpe. and Conv. (E46)	05-06	RWD/AWD	OEMA 67110 72110	OEMA	62 74		72090/ 72095	OEMA 72090/ 72095	74/ 129 74/ 129
3 Series Sedan and Wagon (E46)	04-05	RWD/AWD	OEMA 67110 72110	OEMA	62 74		72090/ 72095	OEMA 72090/ 72095	74/ 129 74/ 129
3 Series Z4 (E85)	03-08	RWD	OEMA 67110 72110	OEMA	62 74		72090/ 72095	OEMA 72090/ 72095	74/ 129 74/ 129
3 Series M3 (E46)	00-06	RWD	OEMA	OEMA			N/A	OEMA	
3 Series Cpe. and Conv. (E46)	00-04	RWD/AWD	OEMA 67110 72110	OEMA	62 74		72080/ 72095	OEMA 72080/ 72095	74/ 129 74/ 129
3 Series Sedan and Wagon (E46)	99-03	RWD/AWD	OEMA 67110 72110	OEMA	62 74		72080/ 72095	OEMA 72080/ 72095	74/ 129 74/ 129
3 Series Z3 & M Cpe./Rdstr. (E36)	96-02	RWD	N/A	N/A			72070(10)/ 72095	72070(10)/ 72095	74/ 129 129
3 Series 318, 323, 325, 328 M3 (E36)	92-99	RWD	OEMA 67110 72110	OEMA	62 74		72070(10)/ 72095	72070(10)/ 72095	74/ 129 129
3 Series 318Ti (E30)	92-99	RWD	N/A	N/A			72090/ 72095	72090/ 72095	74/ 129
3 Series (E30)	84-91	RWD/AWD	N/A	N/A			72065/ 72095	72065/ 72095	74/ 129
5 Series (F07)	10-13	RWD/AWD	N/A	N/A			N/A	N/A	
5 Series, inc. M5 (F10,F11)	10-13	RWD/AWD	OEMA	OEMA			N/A	N/A	
5 Series (E60, 61)	06-09	AWD	OEMA	OEMA			N/A	N/A	
5 Series (E60, 61)	04-09	RWD	OEMA	OEMA			N/A	OEMA	
5 Series 528i w/EDC, 540i, 540iT, M5 (E39)	96-04	RWD	OEMA 72185/ 72509	OEMA 72185/ 72509	75/ 129		72180/ 72095	72180/ 72095	75/ 129
5 Series (E39) 525i, 528i w/o EDC, 528iT, 530i	96-03	RWD	OEMA 72185/ 72509	OEMA 72185/ 72509	75/ 129		72080/ 72095	72080/ 72095	74/ 129
5 Series (E23, E34)	87-95	RWD	N/A	N/A			N/A	N/A	
6 Series Coupe, Conv. (F12, F13)	11-13	RWD/AWD	OEMA	OEMA			N/A	N/A	
6 Series M6 (E63)	04-11	RWD	72185/ 72509	72185/ 72509	75/ 129		N/A	N/A	
6 Series	80-89	RWD	N/A	N/A			N/A	N/A	
7 Series (F01,F02)	09-13	RWD/AWD	OEMA	OEMA			N/A	N/A	
7 Series High Security (F03)	09-13	RWD/AWD	OEMA	OEMA			N/A	N/A	
7 Series Hybrid (F04)	09-13	RWD/AWD	OEMA	OEMA			N/A	N/A	
7 Series (E65,66,67,68)	02-08	RWD	OEMA	OEMA			N/A	OEMA	
7 Series 740, 750 (E38)	95-01	RWD	OEMA	OEMA			N/A	N/A	
7 Series 733, 735, 740, 750 (E23, 32)	87-94	RWD	N/A	N/A			N/A	N/A	
8 Series Z8 Rdstr. (E52)	00-04	RWD	OEMA	OEMA			N/A	N/A	
8 Series (E31)	90-99	RWD	N/A	N/A			N/A	N/A	
X-1 (E84)	12-13	RWD/AWD	N/A	N/A			N/A	N/A	
X-3 (F25)	11-13	AWD	OEMA	OEMA			N/A	OEMA	
X-3 (E83)	05-10	AWD	OEMA	OEMA			N/A	OEMA	
X-5 (E70)	07-13	AWD	OEMA	OEMA			N/A	N/A	
X-5 (E53)	00-06	AWD	OEMA	OEMA			N/A	81280	79
X-6 (E71)	08-13	AWD	OEMA	OEMA			N/A	N/A	

ALIGNMENT FOOTNOTES BOLD PART NUMBER INDICATES PREFERRED CORRECTION METHOD

- (1) = CAUTION: Check for caliper to rotor clearance with disc brakes. Use spacer set 75970 (pg. 78) as necessary to keep caliper centered on rotor • (2) = All EXCEPT RWD 1500
- (3) = Honda S2000 Ball Joint - Rear Application - Only for 17" rims or larger • (4) = Check Bolt Length BEFORE Cutting Hole • (5) = Shims (pg. 58)
- (6) = LH Tie Rod Adjusting Sleeve Replacement (pg. 53) • (7) = Bolts, 73415, are necessary for changes greater than 3/4" (pg. 77) • (8) = Recommended for vehicles lowered more than 1.5"
- (9) = Will not work on 1988-89 models with welded-in ball joint • (10) = M3 Only, caster will decrease by 2 degrees • (11) = Pinion Angle Adj. Part No. 82370 (pg. 81)
- (12) = Limited camber range of ±1.0° • (13) = Center stock camber and toe adjusters before calculating shim change • (14) = 69330 included w/69300 or 69400 • (15) = Not for use w/disc brake
- = Thrust Alignment Plate can correct thrust angle and setback (pg. 59) / Check frame angle with Angle Gauge Part No. 64225 (pg. 127)
- N/A = No Available Adjuster • OEMA = Original Equipment Manufacturer Adjustment • (*) = Series P/N, for correct size • SW = Station Wagon

©2013 Niwot Corp. dba Specialty Products Co.®

All products from Specialty Products Company are intended for use by professional installers only.



www.specprod.com

Call for your nearest distributor, product info or
Technical Assistance • In the USA and Canada

1-800-525-6505

Applications
Parts
Heavy Duty
Facing/All Road
Tools
Accessories
Brake & CV
Gear/Index

Applications

CAR/MINI-VAN/SUV/TRUCK APPLICATIONS

BUICK			REAR			FRONT			
Model/Body Style	Year	Drive Type	CAMBER/TOOL	TOE/TOOL	Page	Thrust Plate	CASTER/TOOL	CAMBER/TOOL	Page
Apollo 'X' Body <i>Pro Springs-Pg. 94</i>	73-74	RWD	N/A	N/A			OEMA(5) 94305 94374 (Lower)	OEMA(5) 94305	92,92 94
Century	97-05	FWD	81260	OEMA	79		N/A	81260	79
Century	82-96	FWD	75600 or 75800(1)	75600 or 75800(1)	78,78		N/A	82110/85130	81/133
Century	73-77	RWD	N/A	N/A			OEMA(5) 94340 94378 (Lower)	OEMA(5) 94340	92,92 94
Electra	85-90	FWD	81280 82120/85130	OEMA	79 81/133		OEMA	81280 82120/85130	79 81/133
Enclave	08-13	FWD/AWD	OEMA	OEMA			N/A	81280	79
Encore	13-14	FWD	71060*	71050*	72,72		N/A	81260	79
Estate SW	80-90	RWD	N/A	N/A			OEMA(5)	OEMA(5)	
Grand National <i>Pro Springs-Pg. 94</i>	78-87	RWD	N/A	N/A			OEMA(5) 94330, 94331 94332(8) 95336 (Lower)	OEMA(5) 94330, 94331 94332(8)	92,92 92,92 95
Grand National <i>Pro Springs-Pg. 94</i>	73-77	RWD	N/A	N/A			OEMA(5) 94340 94378 (Lower)	OEMA(5) 94340	92,92 94
GS	64-72	RWD	N/A	N/A			OEMA(5) 94320 94344 (Lower)	OEMA(5) 94320	92,92 93
LaCrosse/Allure w/o Perf. Package	10-13	FWD/AWD	OEMA	OEMA			N/A	81250	79
LaCrosse/Allure	05-09	FWD	81260	OEMA	79		N/A	81250	79
LeSabre	00-06	FWD	75600 or 75800(1)	OEMA 75600 or 75800(1)	78,78 78,78		OEMA	81280 82120/85130	79 81/133
LeSabre	86-99	FWD	81280 82120/85130	OEMA	79 81/133		OEMA	81280 82120/85130	79 81/133
LeSabre <i>Pro Springs-Pg. 94</i>	71-85	RWD	N/A	N/A			OEMA(5) 94340 94378 (Lower)	OEMA(5) 94340	92,92 94
Lucerne	06-11	FWD	75600 or 75800(1)	OEMA 75600 or 75800(1)	78,78 78,78		N/A	81280 82120/85130	79 81/133
Park Avenue	97-05	FWD	75600 or 75800(1)	OEMA 75600 or 75800(1)	78,78 78,78		OEMA	81280 82120/85130	79 81/133
Park Avenue	90-96	FWD	81280 82120/85130	OEMA	79 81/133		OEMA	81280 82120/85130	79 81/133
Rainier	04-07	RWD/4WD	N/A	N/A			OEMA/83785	OEMA/83785	132,132
Reatta	89-91	FWD	75600 or 75800(1)	OEMA 75600 or 75800(1)	78,78 78,78		OEMA	81280 82120/85130	79 81/133
Regal	11-13	FWD	OEMA	OEMA			N/A	81250	79
Regal	97-04	FWD	81260	OEMA/83850	79/133		N/A	81260	79
Regal <i>40930 - Front Strut Set-Page 126</i>	88-96	FWD	81280 82120/85130	OEMA/83850	79/133 81/133		N/A	N/A/85130	133
Regal <i>Pro Springs-Pg. 94</i>	78-87	RWD	N/A	N/A			OEMA(5) 94330, 94331 94332(8) 95336 (Lower)	OEMA(5) 94330, 94331 94332(8)	92,92 92,92 95
Regal <i>Pro Springs-Pg. 94</i>	73-77	RWD	N/A	N/A			OEMA(5) 94340 94378 (Lower)	OEMA(5) 94340	92,92 94
Rendezvous	02-07	AWD	OEMA	OEMA			N/A	81260	79
Rendezvous	02-07	FWD	75600 or 75800(1)	75600 or 75800(1)	78,78		N/A	81260	79
Riviera	95-99	FWD	75600 or 75800(1)	OEMA 75600 or 75800(1)	78,78 78,78		OEMA	81280 82120/85130	79 81/133
Riviera	86-93	FWD	75600 or 75800(1)	OEMA/83775 75600 or 75800(1)	78,78/132 78,78		OEMA	OEMA 81280 82120/85130	79 81/133
Riviera	79-85	FWD	75600 or 75800(1)	OEMA/83775 75600 or 75800(1)	78,78/132 78,78		OEMA	OEMA	
Roadmaster & SW	91-96	RWD	N/A	N/A			OEMA(5)	OEMA(5)	
Skyhawk	82-89	FWD	75400(1)	75400(1)	78,78		N/A	81280 82120/85130	79 81/133
Skylark	96-98	FWD	75400(1)	75400(1)	78,78		N/A	81260	79

CAR/MINI-VAN/SUV/TRUCK APPLICATIONS

BUICK-cont.			REAR			Thrust Plate	FRONT		
Model/Body Style	Year	Drive Type	CAMBER/TOOL	TOE/TOOL	Page		CASTER/TOOL	CAMBER/TOOL	Page
Skylark	86-95	FWD	75400(1)	75400(1)	78,78		N/A	81280 82120/ 85130	79 81/ 133
Skylark	80-85	FWD	75400(1)	75400(1)	78,78		N/A	82110/ 85130	81/ 133
Skylark 'X' Body <i>Pro Springs-Pg. 94</i>	75-79	RWD	N/A	N/A			OEMA(5) 94340 94378 (Lower)	OEMA(5) 94340	92,92 94
Skylark <i>Pro Springs-Pg. 94</i>	64-72	RWD	N/A	N/A			OEMA(5) 94320 94344 (Lower)	OEMA(5) 94320	92,92 93
Special <i>Pro Springs-Pg. 94</i>	64-72	RWD	N/A	N/A			OEMA(5) 94320 94344 (Lower)	OEMA(5) 94320	92,92 93
Somerset	85-89	FWD	75400(1)	75400(1)	78,78		N/A	81280 82120/ 85130	79 81/ 133
Terraza	05-06	AWD	OEMA	OEMA			N/A	81260	79
Terraza	05-07	FWD	75600 or 75800(1)	75600 or 75800(1)	78,78		N/A	81260	79
Verano	12-14	FWD	71040*	71030*	72,72		N/A	81250	79

CADILLAC									
Model/Body Style	Year	Drive Type	CAMBER/TOOL	TOE/TOOL	Page	Thrust Plate	CASTER/TOOL	CAMBER/TOOL	Page
Allante	93-93	FWD	OEMA	OEMA			OEMA/ 85130	81280 82120/ 85130	133 /79 81/ 133
Allante	87-92	FWD	N/A	OEMA			OEMA/ 85130	81280 82120/ 85130	133 /79 81/ 133
ATS	13-13	RWD/AWD	N/A	N/A			N/A	N/A	
Brougham	85-92	RWD	N/A	N/A			OEMA(5)	OEMA(5)	
Catera	97-01	RWD	N/A	OEMA			N/A	81250	79
Cimarron	82-88	FWD	75400(1)	75400(1)	78,78		N/A	81280 82120/ 85130	79 81/ 133
Concours (94)	94-99	FWD	OEMA	OEMA			OEMA	81280 82120/ 85130	79 81/ 133
CTS/CTS V	08-13	RWD/AWD	OEMA	OEMA			OEMA/ 83785	OEMA/ 83785	132,132
CTS	03-08	RWD/AWD	OEMA	OEMA			OEMA/ 83850, 83775, 83785	OEMA/ 83850, 83775, 83785	133,133 132,132
Deville	00-05	FWD	75600 or 75800(1)	OEMA 75600 or 75800(1)	78,78 78,78		OEMA	81280 82120/ 85130	79 81/ 133
Deville	94-99	FWD	OEMA	OEMA			OEMA	81280 82120/ 85130	79 81/ 133
Deville	85-93	FWD	OEMA 82120/ 85130	OEMA	81/ 133		OEMA/ 85130	OEMA 82120/ 85130	133 81/ 133
DTS	06-11	FWD	75600 or 75800(1)	OEMA 75600 or 75800(1)	78,78 78,78		OEMA	81280 82120/ 85130	79 81/ 133
Eldorado	93-03	FWD	OEMA	OEMA			OEMA/ 85130	81280 82120/ 85130	133 /79 81/ 133
Eldorado	86-92	FWD	75600 or 75800(1)	OEMA/ 83775 75600 or 75800(1)	78,78/ 132 78,78		OEMA	OEMA 81280 82120/ 85130	79 81/ 133
Eldorado	80-85	FWD	75600 or 75800(1)	OEMA/ 83775 75600 or 75800(1)	78,78/ 132 78,78		OEMA	OEMA	
ELR	13-14	FWD	71040*	71030*	72,72		N/A	81250	79
Escalade ESV/EXT <i>JounceShock System Avail.-Pg. 120</i>	02-13	RWD/4WD	N/A	N/A			OEMA/ 45940 86320, 86325, 86375	OEMA/ 45940 86350/ 72509, 79500 86320, 86325, 86375	127,127 85/ 129,131 85,85,86,86
Escalade	99-00	RWD/4WD	N/A	N/A			OEMA 87400/ 74910 83790/ 74910	OEMA 87400/ 74910 83790/ 74910	88/ 129 83/ 129
Fleetwood	85-93	FWD	OEMA	OEMA			OEMA/ 85130	OEMA 82120/ 85130	133 81/ 133
Seville STS/SLS	98-04	FWD	75600 or 75800(1)	OEMA 75600 or 75800(1)	78,78 78,78		OEMA	81280 82120/ 85130	79 81/ 133
Seville STS/SLS	93-97	FWD	OEMA	OEMA			N/A	81280 82120/ 85130	79 81/ 133

ALIGNMENT FOOTNOTES BOLD PART NUMBER INDICATES PREFERRED CORRECTION METHOD

- (1) = CAUTION: Check for caliper to rotor clearance with disc brakes. Use spacer set 75970 (pg. 78) as necessary to keep caliper centered on rotor • (2) = All EXCEPT RWD 1500
 (3) = Honda S2000 Ball Joint - Rear Application - Only for 17" rims or larger • (4) = Check Bolt Length BEFORE Cutting Hole • (5) = Shims (pg. 58)
 (6) = LH Tie Rod Adjusting Sleeve Replacement (pg. 53) • (7) = Bolts, 73415, are necessary for changes greater than 3/4" (pg. 77) • (8) = Recommended for vehicles lowered more than 1.5"
 (9) = Will not work on 1988-89 models with welded-in ball joint • (10) = M3 Only, caster will decrease by 2 degrees • (11) = Pinion Angle Adj. Part No. 82370 (pg. 81)
 (12) = Limited camber range of ±1.0° • (13) = Center stock camber and toe adjusters before calculating shim change • (14) = 69330 included w/69300 or 69400 • (15) = Not for use w/disc brake
 ■ = Thrust Alignment Plate can correct thrust angle and setback (pg. 59) / Check frame angle with Angle Gauge Part No. 64225 (pg. 127)
 N/A = No Available Adjuster • OEMA = Original Equipment Manufacturer Adjustment • (*) = Series P/N, for correct size • SW = Station Wagon

©2013 Niwot Corp. dba Specialty Products Co.®

All products from Specialty Products Company are intended for use by professional installers only.



www.specprod.com

Call for your nearest distributor, product info or
Technical Assistance • In the USA and Canada

1-800-525-6505

Applications
Parts
Heavy Duty
Facing/Off Road
Tools
Accessories
Brake & CV
Gear/Index

CAR/MINI-VAN/SUV/TRUCK APPLICATIONS

CADILLAC-cont.

Model/Body Style Year Drive Type REAR CAMBER/TOOL TOE/TOOL Page Thrust Plate FRONT CASTER/TOOL CAMBER/TOOL Page

Seville	86-92	FWD	75600 or 75800(1)	OEMA/83775 75600 or 75800(1)	78,78/132 78,78		OEMA	OEMA 81280 82120/85130	79 81/133
Seville	80-85	FWD	75600 or 75800(1)	OEMA/83775 75600 or 75800(1)	78,78/132 78,78		OEMA	OEMA	
SRX	10-13	FWD/AWD	OEMA 75400(1)(13)	OEMA 75400(1)(13)	78,78		N/A	81280	79
SRX	04-09	RWD/AWD	OEMA	OEMA/83850	132		OEMA/83775, 83785	OEMA/83775, 83785	132,132 132,132
STS	05-11	RWD/AWD	OEMA	OEMA			OEMA/83785	OEMA/83785	132,132
XLR/XLR V	04-09	RWD	OEMA	OEMA			OEMA	OEMA	
XTS	13-13	RWD/AWD	N/A	N/A			N/A	N/A	

CHEVROLET/GMC

1500, Silverado, Sierra <i>JounceShock System Avail.-Pg. 120</i>	99-13	RWD/4WD	N/A	N/A		■	OEMA/45940 86320 86325, 86375	OEMA/45940 86350/72509, 79500 83620, 86325, 86375	127,127 85/129,131 85,85,86,86
1500HD Crew Cab	01-06	RWD/4WD	N/A	N/A		■	OEMA/45940 86320 86325, 86375 23960/72509	OEMA/45940 86330/72509, 79500 86320, 86325, 86375 23960/72509	127,127 85/129,131 85,85,86,86 54/129
1500, 2500, 3500 (1999/2000 'Classic' only)	88-00	RWD/4WD	N/A	N/A		■	OEMA 87400/74910 83790/74910	OEMA 86350(2)/72509, 79500 87400/74910 83790/74910	85/129,131 88/129 83/129
2500, 3500	11-13	RWD/4WD	N/A	N/A		■	OEMA	OEMA	
2500, 3500, Silverado, Sierra	99-10	RWD/4WD	N/A	N/A		■	OEMA/45940 86320 86325, 86375 23960/72509	OEMA/45940 86330/72509, 79500 86320, 86325, 86375 23960/72509	127,127 85/129,131 85,85,86,86 54/129
3500HD Cab/Chassis	91-02	RWD	N/A	N/A		■	Axle Wedges	N/A	
4500, 5500, Kodiak, Topkick	03-09	4WD	N/A	N/A		■	23230*/73119 24230/73119 Axle Wedges	23230*/73119 24230/73119	52/129 55/129
4500, 5500, Kodiak, Topkick	03-09	RWD	N/A	N/A		■	Axle Wedges	N/A	
Acadia	07-13	FWD/AWD	OEMA	OEMA			N/A	81280	79
Astro, Safari	90-05	AWD	N/A	N/A		■	OEMA 87400/74910 83790/74910	OEMA 87400/74910 83790/74910	88/129 83/129
Astro, Safari	85-05	RWD	N/A	N/A		■	OEMA(5) 87135	OEMA(5) 87135	134,134
Avalanche 1500 <i>JounceShock System Avail.-Pg. 120</i>	02-13	RWD/4WD	N/A	N/A		■	OEMA/45940 86320 86325, 86375	OEMA/45940 86350/72509, 79500 86320, 86325, 86375	127,127 85/129,131 85,85,86,86
Avalanche 2500	02-06	4WD	N/A	N/A		■	OEMA/45940 86320 86325, 86375 23960/72509	OEMA/45940 86330/72509, 79500 86320, 86325, 86375 23960/72509	127,127 85/129,131 85,85,86,86 54/129
Aveo	12-14	FWD	71060*	71050*	72,72		N/A	81250	79
Aveo	04-11	FWD	75200(15)	75200(15)	78,78		N/A	81250	79
Beretta	96-97	FWD	75400(1)	75400(1)	78,78		N/A	81260	79
Beretta	87-95	FWD	75400(1)	75400(1)	78,78		N/A	81280 82120/85130	79 81/133
Blazer Full Size	92-94	RWD/4WD	N/A	N/A		■	OEMA 87400/74910 83790/74910	OEMA 86350(2)/72509, 79500 87400/74910 83790/74910	85/129,131 88/129 83/129
Blazer S Series	82-04	4WD	N/A	N/A		■	OEMA 83710	OEMA 83710	83,83
Blazer S Series <i>Pro Springs-Pg. 94</i>	82-04	RWD	N/A	N/A		■	OEMA(5) 94330, 94331 94332(8) 95336 (Lower)	OEMA(5) 94330, 94331 94332(8)	92,92 92,92 95
Blazer K5	69-91	4WD	N/A	N/A		■	23000*/4169	23000*/4169	50/123
Blazer C5	69-91	RWD	N/A	N/A		■	OEMA(5)	OEMA(5)	
C10, C15, C20, C25, C30, C35	73-87	RWD	N/A	N/A		■	OEMA(5) 87135 (C10/15)	OEMA(5) 87135 (C10/15)	134,134
C10, C15, C20, C25, C30, C35	65-72	RWD	N/A	N/A		■	OEMA(5) (ThrustPlate not for	OEMA(5) C10/15)	

CAR/MINI-VAN/SUV/TRUCK APPLICATIONS

CHEVROLET/GMC-cont.			REAR			FRONT			
Model/Body Style	Year	Drive Type	CAMBER/TOOL	TOE/TOOL	Page	Thrust Plate	CASTER/TOOL	CAMBER/TOOL	Page
Camaro	10-14	RWD	OEMA 87430	OEMA 87430	88,88		N/A	OEMA 81280	79
Camaro	93-02	RWD	N/A	N/A			OEMA/ 83775	OEMA/ 83775	132,132
Camaro 'F'-Body	82-92	RWD	N/A	N/A			OEMA	OEMA/ 8292 81280	123 79
Camaro 'F'-Body <i>Pro Springs-Pg. 94</i>	70-81	RWD	N/A	N/A			OEMA(5) 94340 94378 (Lower)	OEMA(5) 94340	92,92 94
Camaro 'F'-Body <i>Pro Springs-Pg. 94</i>	67-69	RWD	N/A	N/A			OEMA(5) 94305 94374 (Lower)	OEMA(5) 94305	92,92 94
Canyon	14-14	RWD/4WD	N/A	N/A			25620	25620	57,57
Canyon <i>JounceShock System Avail.-Pg. 120</i>	04-13	RWD/4WD	N/A	N/A		■	OEMA/ 45940 86360/ 45938 86320, 86325, 86375	OEMA/ 45940 86360/ 45938 86320, 86325, 86375	127,127 85/ 127 85,85,86 85,86
Captiva	12-13	FWD/AWD	OEMA 87420	OEMA 87420	88,88		N/A	81260	79
Caprice PPV	11-13	RWD	OEMA 87430	OEMA 87430	88,88		OEMA	81260	79
Caprice & SW (See Impala)	80-96	RWD	N/A	N/A			OEMA(5)	OEMA(5)	
Caprice 'B' Body	78-96	RWD	N/A	N/A			OEMA(5) 94378 (Lower)	OEMA(5)	94
Caprice 'B' Body	73-77	RWD	N/A	N/A			OEMA(5) 94340 94378 (Lower)	OEMA(5) 94340	92,92 94
Cavalier	95-05	FWD	75400(1)	75400(1)	78,78		N/A	81260	79
Cavalier	82-94	FWD	75400(1)	75400(1)	78,78		N/A	81280	79
Celebrity	82-90	FWD	75600 or 75800(1)	75600 or 75800(1)	78,78		N/A	82110/ 85130	81/ 133
Chevelle <i>Pro Springs-Pg. 94</i>	73-77	RWD	N/A	N/A			OEMA(5) 94340 94378 (Lower)	OEMA(5) 94340	92,92 94
Chevelle <i>Pro Springs-Pg. 94</i>	64-72	RWD	N/A	N/A			OEMA(5) 94320 94344 (Lower)	OEMA(5) 94320	92,92 93
Chevette	76-87	RWD	N/A	N/A			OEMA	OEMA	
Citation	80-85	FWD	75400(1)	75400(1)	78,78		N/A	82110/ 85130	81/ 133
Classic	04-05	FWD	81250	OEMA	79		N/A	81260	79
Cobalt	05-10	FWD	75400(1)	75400(1)	78,78		N/A	81250	79
Colorado	14-14	RWD/4WD	N/A	N/A			25620	25620	57,57
Colorado <i>JounceShock System Avail.-Pg. 120</i>	04-13	RWD/4WD	N/A	N/A		■	OEMA/ 45940 86360/ 45938 86320, 86325, 86375	OEMA/ 45940 86360/ 45938 86320, 86325, 86375	127,127 85/ 127 85,85,86 85,86
Corsica	96-96	FWD	75400(1)	75400(1)	78,78		N/A	81260	79
Corsica	87-95	FWD	75400(1)	75400(1)	78,78		N/A	81280	79
Corvette C5, C6, Z06-ZR1	97-13	RWD	OEMA	OEMA			OEMA	OEMA	
Corvette C4 Late	88-96	RWD	OEMA	OEMA			OEMA(5) 92750, 92751 94370, 94371	OEMA(5) 92750, 92751 (Race) 94370, 94371 (Street)	93,93 93,93
Corvette C4 Early	84-87	RWD	OEMA	OEMA			OEMA(5) 92748, 92749 94368, 94369	OEMA(5) 92748, 92749 (Race) 94368, 94369 (Street)	93,93 93,93
Corvette C2/C3	63-82	RWD	OEMA 83160	OEMA 47170*	82,58		OEMA(5) 92740 94360	OEMA(5) 92740 (Race) 94360 (Street)	93,93 93,93
Cruze	11-14	FWD	71040*	71030*	72,72		N/A	81250	79

ALIGNMENT FOOTNOTES BOLD PART NUMBER INDICATES PREFERRED CORRECTION METHOD

- (1) = CAUTION: Check for caliper to rotor clearance with disc brakes. Use spacer set 75970 (pg. 78) as necessary to keep caliper centered on rotor • (2) = All EXCEPT RWD 1500
 (3) = Honda S2000 Ball Joint - Rear Application - Only for 17" rims or larger • (4) = Check Bolt Length BEFORE Cutting Hole • (5) = Shims (pg. 58)
 (6) = LH Tie Rod Adjusting Sleeve Replacement (pg. 53) • (7) = Bolts, 73415, are necessary for changes greater than 3/4" (pg. 77) • (8) = Recommended for vehicles lowered more than 1.5"
 (9) = Will not work on 1988-89 models with welded-in ball joint • (10) = M3 Only, caster will decrease by 2 degrees • (11) = Pinion Angle Adj. Part No. 82370 (pg. 81)
 (12) = Limited camber range of ±1.0° • (13) = Center stock camber and toe adjusters before calculating shim change • (14) = 69330 included w/69300 or 69400 • (15) = Not for use w/disc brake
 ■ = Thrust Alignment Plate can correct thrust angle and setback (pg. 59) / Check frame angle with Angle Gauge Part No. 64225 (pg. 127)
 N/A = No Available Adjuster • OEMA = Original Equipment Manufacturer Adjustment • (*) = Series P/N, for correct size • SW = Station Wagon

©2013 Niwot Corp. dba Specialty Products Co.®

All products from Specialty Products Company are intended for use by professional installers only.



www.specprod.com

Call for your nearest distributor, product info or
Technical Assistance • In the USA and Canada

1-800-525-6505

CAR / MINI-VAN / SUV / TRUCK APPLICATIONS

CHEVROLET/GMC-cont.			REAR			FRONT			
Model/Body Style	Year	Drive Type	CAMBER/TOOL	TOE/TOOL	Page	Thrust Plate	CASTER/TOOL	CAMBER/TOOL	Page
El Camino <i>Pro Springs-Pg. 94</i>	78-88	RWD	N/A	N/A			OEMA(5) 94330, 94331 94332(8) 95336 (Lower)	OEMA(5) 94330, 94331 94332(8)	92,92 92,92 95
El Camino <i>Pro Springs-Pg. 94</i>	73-77	RWD	N/A	N/A			OEMA(5) 94340 94378 (Lower)	OEMA(5) 94340	92,92 94
El Camino <i>Pro Springs-Pg. 94</i>	64-72	RWD	N/A	N/A			OEMA(5) 94320 94344 (Lower)	OEMA(5) 94320	92,92 93
Envoy	02-09	RWD/4WD	N/A	N/A			OEMA/83785	OEMA/83785	132,132
Envoy	98-00	4WD	N/A	N/A		■	OEMA 83710	OEMA 83710	83,83
Equinox	05-13	FWD/AWD	OEMA 87420	OEMA 87420	88,88		N/A	81260	79
Express, Savana Van	03-13	RWD/4WD	N/A	N/A		■	OEMA/45940 86320 86325, 86375 86370	OEMA/45940 86350/72509, 79500 86320, 86325, 86375 86370	127,127 85/129,131 85,85,86,86 86,86
Express, Savana Van	96-02	RWD	N/A	N/A		■	OEMA 87400/74910 83790/74910	OEMA 87400/74910 83790/74910	88/129 83/129
G10,G20,G30 Van	71-96	RWD	N/A	N/A		■	OEMA(5)	OEMA(5)	
HHR	06-11	FWD	75400(1)	75400(1)	78,78		N/A	81250	79
Impala w/Strut Type Rear Susp.	99-13	FWD	81260	OEMA	79		N/A	81260	79
Impala 'B' Body <i>Pro Springs-Pg. 94</i>	73-96	RWD	N/A	N/A			OEMA(5) 94340 94378 (Lower)	OEMA(5) 94340	92,92 94
Impala	65-72	RWD	N/A	N/A			OEMA 94360	OEMA 94360	93,93
Impala	58-64	RWD	N/A	N/A			OEMA(5) 94360	OEMA(5) 94360	93,93
Jimmy Full Size	88-91	RWD/4WD	N/A	N/A		■	OEMA 87400/74910 83790/74910	OEMA 86350(2)/72509, 79500 87400/74910 83790/74910	85/129,131 88/129 83/129
Jimmy S Series	82-04	4WD	N/A	N/A		■	OEMA 83710	OEMA 83710	83,83
Jimmy S Series <i>Pro Springs-Pg. 94</i>	82-04	RWD	N/A	N/A		■	OEMA(5) 94330, 94331 94332(8) 95336 (Lower)	OEMA(5) 94330, 94331 94332(8)	92,92 92,92 95
Jimmy K5	69-91	4WD	N/A	N/A		■	23000*/4169	23000*/4169	50/123
Jimmy C5	69-91	RWD	N/A	N/A		■	OEMA(5)	OEMA(5)	
K10, K15, K20, K25	70-87	4WD	N/A	N/A		■	23000*/4169	23000*/4169	50/123
K30, V30 Dana 60	88-93	4WD	N/A	N/A		■	Axle Wedges 88940 88950	88940 88950	90,90 90,90
K30, K35	58-87	4WD	N/A	N/A		■	Axle Wedges	23000*/4169	50/123
Kodiak-See 4500, 5500									
Lumina Sedan <i>40930 - Front Strut Set-Page 126</i>	95-01	FWD	81260	OEMA/83850	79/133		N/A	N/A/85130	133
Lumina APV Van	90-96	FWD	75600 or 75800(1)	75600 or 75800(1)	78,78		N/A	82110/85130	81/133
Lumina Sedan <i>40930 - Front Strut Set-Page 126</i>	90-94	FWD	81280 82120/85130	OEMA/83850	79/133 81/133		N/A	N/A/85130	133
Luv	80-82	RWD/4WD	N/A	N/A		■	OEMA(5)	OEMA(5)	
Malibu	13-14	FWD	OEMA	OEMA			N/A	81250	79
Malibu (Maxx)	04-12	FWD	OEMA 75400(1)(13)	OEMA 75400(1)(13)	78,78		N/A	81250	79
Malibu 'Classic'	2008	FWD	OEMA 75400(1)(13)	OEMA 75400(1)(13)	78,78		N/A	81260	79
Malibu 'Classic'	04-05	FWD	81250	OEMA	79		N/A	81260	79
Malibu	97-03	FWD	81250	OEMA	79		N/A	81260	79
Malibu <i>Pro Springs-Pg. 94</i>	78-83	RWD	N/A	N/A			OEMA(5) 94330, 94331 94332(8) 95336 (Lower)	OEMA(5) 94330, 94331 94332(8)	92,92 92,92 95

CAR/MINI-VAN/SUV/TRUCK APPLICATIONS

CHEVROLET/GMC-cont.			REAR			FRONT			
Model/Body Style	Year	Drive Type	CAMBER/TOOL	TOE/TOOL	Page	Thrust Plate	CASTER/TOOL	CAMBER/TOOL	Page
Malibu <i>Pro Springs-Pg. 94</i>	73-77	RWD	N/A	N/A			OEMA(5) 94340 94378 (Lower)	OEMA(5) 94340	92,92 94
Malibu <i>Pro Springs-Pg. 94</i>	64-72	RWD	N/A	N/A			OEMA(5) 94320 94344 (Lower)	OEMA(5) 94320	92,92 93
Metro	98-01	FWD	N/A	OEMA			N/A	81250	79
Monte Carlo	00-07	FWD	81260	OEMA	79		N/A	81260	79
Monte Carlo <i>40930 - Front Strut Set-Page 126</i>	95-99	FWD	81280 82120/ 85130	OEMA/ 83850	79/ 133 81/ 133		N/A	N/A/ 85130	133
Monte Carlo <i>Pro Springs-Pg. 94</i>	78-88	RWD	N/A	N/A			OEMA(5) 94330, 94331 94332(8) 95336 (Lower)	OEMA(5) 94330, 94331 94332(8)	92,92 92,92 95
Monte Carlo <i>Pro Springs-Pg. 94</i>	73-77	RWD	N/A	N/A			OEMA(5) 94340 94378 (Lower)	OEMA(5) 94340	92,92 94
Monte Carlo <i>Pro Springs-Pg. 94</i>	70-72	RWD	N/A	N/A			OEMA(5) 94320 94344 (Lower)	OEMA(5) 94320	92,92 93
Nova	85-88	FWD	81250	OEMA	79		N/A	OEMA 81250	79
Nova 'X' Body <i>Pro Springs-Pg. 94</i>	75-79	RWD	N/A	N/A			OEMA(5) 94340 94378 (Lower)	OEMA(5) 94340	92,92 94
Nova 'X' Body <i>Pro Springs-Pg. 94</i>	68-74	RWD	N/A	N/A			OEMA(5) 94305 94374 (Lower)	OEMA(5) 94305	92,92 94
Optra	03-07	FWD	81250	OEMA	79		N/A	81250	79
Prizm	98-02	FWD	81250 75600 or 75800(1)	OEMA 75600 or 75800(1)	79 78,78		N/A	OEMA 81260	79
R30, R35	88-91	RWD	N/A	N/A		■	OEMA(5)	OEMA(5)	
S10/S15 Pickup	82-04	4WD	N/A	N/A		■	OEMA 83710	OEMA 83710	83,83
S10/S15 Pickup <i>Pro Springs-Pg. 94</i>	82-04	RWD	N/A	N/A		■	OEMA(5) 94330, 94331 94332(8) 95336 (Lower)	OEMA(5) 94330, 94331 94332(8)	92,92 92,92 95
Safari- See Astro									
Savana Van-See Express Van									
Sierra-See 1500 and 2500									
Silverado-See 1500 & 2500									
Sonic	12-14	FWD	71060*	71050*	72,72		N/A	81260	79
Sonoma/S15	82-04	4WD	N/A	N/A		■	OEMA 83710	OEMA 83710	83,83
Sonoma/S15 <i>Pro Springs-Pg. 94</i>	82-04	RWD	N/A	N/A		■	OEMA(5) 94330, 94331 94332(8) 95336 (Lower)	OEMA(5) 94330, 94331 94332(8)	92,92 92,92 95
Spark	13-14	FWD	OEMA	OEMA			N/A	81250	79
Spectrum	85-88	FWD	75200(1)	75200(1)	78,78		N/A	81250	79
Sprint/Sprint Metro	87-88	FWD	N/A	N/A			N/A	OEMA 81250	79
Sprint	85-86	FWD	N/A	N/A			N/A	81250	79
SS	2014	RWD	OEMA 87430	OEMA 87430	88,88		N/A	OEMA 81280	79
SSR	04-06	RWD	N/A	N/A		■	OEMA/ 83785	OEMA/ 83785	132,132

ALIGNMENT FOOTNOTES BOLD PART NUMBER INDICATES PREFERRED CORRECTION METHOD

- (1) = CAUTION: Check for caliper to rotor clearance with disc brakes. Use spacer set 75970 (pg. 78) as necessary to keep caliper centered on rotor • (2) = All EXCEPT RWD 1500
 (3) = Honda S2000 Ball Joint - Rear Application - Only for 17" rims or larger • (4) = Check Bolt Length BEFORE Cutting Hole • (5) = Shims (pg. 58)
 (6) = LH Tie Rod Adjusting Sleeve Replacement (pg. 53) • (7) = Bolts, 73415, are necessary for changes greater than 3/4" (pg. 77) • (8) = Recommended for vehicles lowered more than 1.5"
 (9) = Will not work on 1988-89 models with welded-in ball joint • (10) = M3 Only, caster will decrease by 2 degrees • (11) = Pinion Angle Adj. Part No. 82370 (pg. 81)
 (12) = Limited camber range of ±1.0° • (13) = Center stock camber and toe adjusters before calculating shim change • (14) = 69330 included w/69300 or 69400 • (15) = Not for use w/disc brake
 ■ = Thrust Alignment Plate can correct thrust angle and setback (pg. 59) / Check frame angle with Angle Gauge Part No. 64225 (pg. 127)
 N/A = No Available Adjuster • OEMA = Original Equipment Manufacturer Adjustment • (*) = Series P/N, for correct size • SW = Station Wagon

©2013 Niwot Corp. dba Specialty Products Co.®

All products from Specialty Products Company are intended for use by professional installers only.



www.specprod.com

Call for your nearest distributor, product info or
Technical Assistance • In the USA and Canada

1-800-525-6505

Applications
Parts
Heavy Duty
Facing/Off Road
Tools
Accessories
Brake & CV
Gear/Index

Applications

CAR/MINI-VAN/SUV/TRUCK APPLICATIONS

CHEVROLET/GMC-cont.			REAR			FRONT			
Model/Body Style	Year	Drive Type	CAMBER/TOOL	TOE/TOOL	Page	Thrust Plate	CASTER/TOOL	CAMBER/TOOL	Page
Suburban 1500 <i>JounceShock System Avail.-Pg. 120</i>	00-13	RWD/4WD	N/A	N/A			OEMA/45940 86320, 86325, 86375	OEMA/45940 86350/72509, 79500 86320, 86325, 86375	127,127 85/129,131 85,85,86,86
Suburban 2500	00-13	RWD/4WD	N/A	N/A		■	OEMA/45940 86320, 86325, 86375 23960/72509	OEMA/45940 86330/72509, 79500 86320, 86325, 86375 23960/72509	127,127 85/129,131 85,85,86,86 54/129
Suburban	92-99	RWD/4WD	N/A	N/A		■	OEMA 87400/74910 83790/74910	OEMA 86350(2)/72509, 79500 87400/74910 83790/74910	85/129,131 88/129 83/129
Suburban	69-91	4WD	N/A	N/A		■	23000*/4169	23000*/4169	50/123
Suburban	65-91	RWD	N/A	N/A		■	OEMA(5)	OEMA(5)	
Tahoe <i>JounceShock System Avail.-Pg. 120</i>	00-13	RWD/4WD	N/A	N/A			OEMA/45940 86320, 86325, 86375	OEMA/45940 86350/72509, 79500 86320, 86325, 86375	127,127 85/129,131 85,85,86,86
Tahoe	95-99	RWD/4WD	N/A	N/A		■	OEMA 87400/74910 83790/74910	OEMA 86350(2)/72509, 79500 87400/74910 83790/74910	85/129,131 88/129 83/129
Terrain	05-13	FWD/AWD	OEMA 87420	OEMA 87420	88,88		N/A	81260	79
Topkick-See 4500, 5500									
Tracker	98-04	4WD	N/A	N/A		■	N/A	81250	79
Trailblazer	02-09	RWD/4WD	N/A	N/A			OEMA/83785	OEMA/83785	132,132
Traverse	09-13	FWD/AWD	OEMA	OEMA			N/A	81280	79
'Tri-5' Body	55-57	RWD	N/A	N/A			OEMA(5) 94350	OEMA(5) 94350	93,93
Typhon	92-93	4WD	N/A	N/A		■	OEMA 83710	OEMA 83710	83,83
Uplander	05-06	AWD	OEMA	OEMA			N/A	81260	79
Uplander	05-08	FWD	75600 or 75800(1)	75600 or 75800(1)	78,78		N/A	81260	79
V30, V35 Dana 60	88-93	4WD	N/A	N/A			Axle Wedges 88940 88950	88940 88950	90,90 90,90
Venture	97-05	FWD	75600 or 75800(1)	75600 or 75800(1)	78,78		N/A	81260	79
Venture	02-05	AWD	OEMA	OEMA			N/A	81260	79
Volt	11-14	FWD	71040*	71030*	72,72		N/A	81250	79
Yukon <i>JounceShock System Avail.-Pg. 120</i>	00-13	RWD/4WD	N/A	N/A			OEMA/45940 86320, 86325, 86375	OEMA/45940 86350/72509, 79500 86320, 86320, 86325	127,127 85/129,131 85,85,86,86
Yukon	92-99	RWD/4WD	N/A	N/A			OEMA 87400/74910 83790/74910	OEMA 86350(2)/72509, 79500 87400/74910 83790/74910	127,127 88/129 83/129
Yukon XL 1500 <i>JounceShock System Avail.-Pg. 120</i>	00-13	RWD/4WD	N/A	N/A			OEMA/45940 86320, 86325, 86375	OEMA/45940 86350/72509, 79500 86320, 86375, 86325	127,127 85/129,131 85,85,86,86
Yukon XL 2500	00-13	RWD/4WD	N/A	N/A			OEMA/45940 86320, 86325, 86375	OEMA/45940 86330/72509, 79500 86320, 86325, 86375	127,127 85/129,131 85,85,86,86

CHRYSLER									
Model/Body Style	Year	Drive Type	CAMBER/TOOL	TOE/TOOL	Page	Thrust Plate	CASTER/TOOL	CAMBER/TOOL	Page
All Pass. Car Models	60-73	RWD	N/A	N/A			OEMA 83160	OEMA 83160	82,82
Aspen	07-09	RWD/AWD	N/A	N/A			OEMA	OEMA	
200	11-13	FWD	67018 75600(1)	75600(1)	60,78 78		N/A	81260	79
300	09-13	RWD	66050/66025,40920	OEMA	60/128,125		OEMA 66045	OEMA 66045	59,59
300	05-13	AWD	66050/66025,40920	OEMA	60/128,125		OEMA	OEMA	
300	05-08	RWD	66050/66025,40920	OEMA	60/128,125		OEMA 66040	OEMA 66040	59,59
300 M (6) <i>55700, toe tool-Pg. 127</i>	99-04	FWD	67080	OEMA	62		N/A	81280 82120/85130	79 81/133
Cirrus	95-00	FWD	OEMA	OEMA			N/A	67180/40920	63/125
Concorde (6) <i>55700, toe tool-Pg. 127</i>	98-04	FWD	67080	OEMA	62		N/A	81280 82120/85130	79 81/133

CAR/MINI-VAN/SUV/TRUCK APPLICATIONS

CHRYSLER-cont.			REAR			FRONT			
Model/Body Style	Year	Drive Type	CAMBER/TOOL	TOE/TOOL	Page	Thrust Plate	CASTER/TOOL	CAMBER/TOOL	Page
Concorde 55600, toe tool-Pg. 127	93-97	FWD	67020	OEMA			N/A	81280 82120/ 85130	79 81/ 133
Crossfire (Inc. SRT6)	03-07	RWD	28840/ 72509,75990	OEMA	57/ 131,129		OEMA	OEMA	
E-Class/ Exec. Sedan	83-86	FWD	75200 (1)	75200 (1)	78,78		N/A	OEMA 83170/ 85130	82/ 133
Fifth Ave.	90-93	FWD	75200 (1)	75200 (1)	78,78		N/A	OEMA 83170/ 85130	82/ 133
Imperial	90-93	FWD	75200 (1)	75200 (1)	78,78		N/A	OEMA 83170/ 85130	82/ 133
Imperial	81-83	RWD	N/A	N/A			OEMA/ 8286	OEMA/ 8286	123,123
Laser	84-86	FWD	75200 (1)	75200 (1)	78,78		N/A	OEMA 83170/ 85130	82/ 133
LeBaron	82-95	FWD	75200 (1)	75200 (1)	78,78		N/A	OEMA 83170/ 85130	82/ 133
LHS (6) 55700, toe tool-Pg. 127	98-01	FWD	67080	OEMA	62		N/A	81280 82120/ 85130	79 81/ 133
LHS 55600, toe tool-Pg. 127	94-97	FWD	67020	OEMA	60		N/A	81280 82120/ 85130	79 81/ 133
New Yorker 55600, toe tool-Pg. 127	94-97	FWD	67020	OEMA	60		N/A	81280 82120/ 85130	79 81/ 133
New Yorker	83-93	FWD	75200 (1)	75200 (1)	78,78		N/A	OEMA 83170/ 85130	82/ 133
New Yorker 5th Ave.	83-89	RWD	N/A	N/A			OEMA	OEMA	
Pacifica	04-08	AWD/FWD	66050/ 66025,40920	OEMA	60/ 128,125		N/A	81260	79
PT Cruiser	01-10	FWD	75200 (1)	75200 (1)	78,78		N/A	81260	79
Sebring Sedan & Conv.	07-10	FWD	67015	OEMA	60		N/A	81260	79
Sebring Sedan & Conv.	04-06	FWD	67025	OEMA	60		N/A	67180/ 40920	63/ 125
Sebring 2Dr. Coupe	01-06	FWD	73600 73620 (8) 73400+73415 (7)	OEMA	77 77 77,77		N/A	81280 82120/ 85130	79 81/ 133
Sebring Sedan & Conv.	01-03	FWD	OEMA	OEMA			N/A	67180/ 40920	63/ 125
Sebring Conv.	96-00	FWD	OEMA	OEMA			N/A	67180/ 40920	63/ 125
Sebring	95-00	FWD	73600 73620 (8) 73400+73415 (7)	OEMA	77 77 77,77			67170,40920 67370 (8)/40920	63/ 125 65/ 125
Town & Country	01-13	AWD	N/A	N/A			N/A	81260 83170/ 85130	79 82/ 133
Town & Country w/ ABS	01-13	FWD	N/A	N/A			N/A	81260 83170/ 85130	79 82/ 133
Town & Country w/o ABS	01-13	FWD	71730 *(1)	71720 *(1)	72,72		N/A	81260 83170/ 85130	79 82/ 133
Town & Country	96-00	AWD	N/A	N/A			N/A	OEMA 83170/ 85130	82/ 133
Town & Country w/ ABS	96-00	FWD	N/A	N/A			N/A	OEMA 83170/ 85130	82/ 133
Town & Country w/o ABS	96-00	FWD	71730*	71720*	72,72		N/A	OEMA 83170/ 85130	82/ 133
Town & Country	90-95	AWD	N/A	N/A			N/A	OEMA 83170/ 85130	82/ 133
Town & Country	90-95	FWD	75400 (1)	75400 (1)	78,78		N/A	OEMA 83170/ 85130	82/ 133
Town & Country	82-88	FWD	75200 (1)	75200 (1)	78,78		N/A	OEMA 83170/ 85130	82/ 133
Voyager	00-03	AWD	N/A	N/A			N/A	81260 83170/ 85130	79 82/ 133
Voyager w/o ABS	00-03	FWD	71730*	71720*	72,72		N/A	81260 83170/ 85130	79 82/ 133
Voyager w/ ABS	00-03	FWD	N/A	N/A			N/A	81260 83170/ 85130	79 82/ 133

ALIGNMENT FOOTNOTES BOLD PART NUMBER INDICATES PREFERRED CORRECTION METHOD

- (1) = CAUTION: Check for caliper to rotor clearance with disc brakes. Use spacer set 75970 (pg. 78) as necessary to keep caliper centered on rotor • (2) = All EXCEPT RWD 1500
 (3) = Honda S2000 Ball Joint - Rear Application - Only for 17" rims or larger • (4) = Check Bolt Length BEFORE Cutting Hole • (5) = Shims (pg. 58)
 (6) = LH Tie Rod Adjusting Sleeve Replacement (pg. 53) • (7) = Bolts, 73415, are necessary for changes greater than 3/4" (pg. 77) • (8) = Recommended for vehicles lowered more than 1.5"
 (9) = Will not work on 1988-89 models with welded-in ball joint • (10) = M3 Only, caster will decrease by 2 degrees • (11) = Pinion Angle Adj. Part No. 82370 (pg. 81)
 (12) = Limited camber range of ±1.0° • (13) = Center stock camber and toe adjusters before calculating shim change • (14) = 69330 included w/69300 or 69400 • (15) = Not for use w/disc brake
 ■ = Thrust Alignment Plate can correct thrust angle and setback (pg. 59) / Check frame angle with Angle Gauge Part No. 64225 (pg. 127)
 N/A = No Available Adjuster • OEMA = Original Equipment Manufacturer Adjustment • (*) = Series P/N, for correct size • SW = Station Wagon

©2013 Niwot Corp. dba Specialty Products Co.®

All products from Specialty Products Company are intended for use by professional installers only.



www.specprod.com

Call for your nearest distributor, product info or
Technical Assistance • In the USA and Canada

1-800-525-6505

Applications
Parts
Heavy Duty
Racing/Off Road
Tools
Accessories
Brake & CV
Gear/Index

Applications

CAR/MINI-VAN/SUV/TRUCK APPLICATIONS

DAEWOO			REAR		Page	Thrust Plate	FRONT		Page
Model/Body Style	Year	Drive Type	CAMBER/TOOL	TOE/TOOL			CASTER/TOOL	CAMBER/TOOL	
Lanos	98-02	FWD	N/A	N/A			N/A	N/A	
Leganza	98-02	FWD	81250	OEMA	79		N/A	81250	79
Nubira	98-02	FWD	81250	OEMA	79		N/A	81250	79
DAIHATSU									
Charade	88-92	FWD	81250	OEMA	79		N/A	81250	79
Rocky	90-92	4WD	N/A	N/A			OEMA(5)	OEMA(5)	
DODGE/RAM									
400	82-83	FWD	75200(1)	75200(1)	78,78		N/A	OEMA 83170/85130	82/133
600	83-88	FWD	75200(1)	75200(1)	78,78		N/A	OEMA 83170/85130	82/133
1500 Ram Exc. Mega Cab	06-13	RWD/4WD	N/A	N/A		■	OEMA 23940/72509	OEMA 23940/72509	54/129
1500 Ram Mega Cab	06-13	4WD	N/A	N/A		■	23800-23830/ 23780, 72509	23800-23830/ 23780, 72509	54,54 123,129
1500 Ram Mega Cab	06-13	RWD	N/A	N/A		■	OEMA	OEMA	
1500 Ram	02-05	4WD	N/A	N/A		■	OEMA 23755	OEMA 23755	53,53
1500 Ram	02-05	RWD	N/A	N/A		■	OEMA 23765	OEMA 23765	53,53
1500 Ram	94-01	4WD	N/A	N/A		■	23510-23540/ 23580, 72509 82380 (Caster &	23510-23540/ 23580, 72509 Pinion Angle)	53,53 123,129 81
1500 Ram	94-01	RWD	N/A	N/A		■	OEMA/8286	OEMA/8286	123,123
2500 Ram	03-13	4WD	N/A	N/A		■	23800-23830/ 23780, 72509 82385 (Caster &	23800-23830/ 23780, 72509 Pinion Angle)	54,54 123,129 82
2500 Ram	03-13	RWD	N/A	N/A		■	OEMA	OEMA	
2500 Ram	00-02	4WD	N/A	N/A		■	23710-23730/ 23780, 72509 82385 (Caster &	23710-23730/ 23780, 72509 Pinion Angle)	53,53 123,129 82
2500 HD	94-99	4WD	N/A	N/A		■	23130*/ 77880, 88830 24130/74500 82395 (Caster &	23130*/ 77880, 88830 24130/74500 Pinion Angle)	51,51 131,135 55/129 82
2500 Ram	94-99	RWD	N/A	N/A		■	OEMA/8286	OEMA/8286	123,123
2500 Ram w/LD Dana 44 Fr Axle	94-99	4WD	N/A	N/A		■	23510-23540/ 23580, 72509 82380 (Caster &	23510-23540/ 23580, 72509 Pinion Angle)	53,53 123,129 81
3500 Ram	03-13	4WD	N/A	N/A		■	23800-23830/ 23780, 72509 82385 (Caster &	23800-23830/ 23780, 72509 Pinion Angle)	54,54 123,129 82
3500 Ram	00-13	RWD	N/A	N/A		■	OEMA	OEMA	
3500 Ram w/mono beam	03-13	RWD	N/A	N/A		■	23800-23830/ 23780, 72509 82385 (Caster &	23800-23830/ 23780, 72509 Pinion Angle)	54,54 123,129 82
3500 Ram	00-02	4WD	N/A	N/A		■	23710-23730/ 23780, 72509 82385 (Caster &	23710-23730/ 23780, 72509 Pinion Angle)	53,53 123,129 82
3500 Ram w/mono beam	00-02	RWD	N/A	N/A		■	23710-23730/ 23780, 72509 82385 (Caster &	23710-23730/ 23780, 72509 Pinion Angle)	53,53 123,129 82
3500 Ram	94-99	4WD	N/A	N/A		■	23130*/ 77880, 88830 24130/74500 82395 (Caster &	23130*/ 77880, 88830 24130/74500 Pinion Angle)	51,51 131,135 55/129 82
3500 Ram	94-99	RWD	N/A	N/A		■	OEMA/8286	OEMA/8286	123,123
3500 Ram w/mono beam	94-99	RWD	N/A	N/A		■	23130*/ 77880, 88830 24130/74500 82395 (Caster &	23130*/ 77880, 88830 24130/74500 Pinion Angle)	51,51 131,135 55/129 82
4500 / 5500 Ram	08-13	4WD	N/A	N/A		■	N/A	23850-23854/ 23780, 72509, 88360	54,54 123,129,135
4500 / 5500 Ram	08-13	RWD	N/A	N/A		■	23850-23854/ 23780, 72509, 88360	23850-23854/ 23780, 72509, 88360	54,54 123,129,135 135
AD150 Ramcharger	90-96	RWD	N/A	N/A		■	OEMA/8286	OEMA/8286	123,123
AD150 Ramcharger	72-89	RWD	N/A	N/A		■	OEMA 83160	OEMA 83160	82,82

CAR/MINI-VAN/SUV/TRUCK APPLICATIONS

DODGE/RAM-cont.			REAR			FRONT			
Model/Body Style	Year	Drive Type	CAMBER/TOOL	TOE/TOOL	Page	Thrust Plate	CASTER/TOOL	CAMBER/TOOL	Page
All Passenger B & E Models (Except 880)	62-65	RWD	N/A	N/A			OEMA 94450, 94451	OEMA 94450, 94451	95,95
All Passenger Car Models (Except B & E)	60-73	RWD	N/A	N/A			OEMA 83160	OEMA 83160	82,82
Aries	81-89	FWD	75200(1)	75200(1)	78,78		N/A	OEMA 83170/85130	82/133
Avenger	11-13	AWD	67018	OEMA	60		N/A	81260	79
Avenger	11-13	FWD	67018 75600(1)	75600(1)	60,78 78		N/A	81260	79
Avenger	08-10	FWD/AWD	67015	OEMA	60		N/A	81260	79
Avenger	95-00	FWD	73600 73620(8) 73400+73415(7)	OEMA	77 77 77,77		N/A	67170/40920 67370(8)/40920	63/125 65/125
B150, B250, B350 Ram Van	81-01	RWD	N/A	N/A		■	OEMA/8286	OEMA/8286	123,123
B100, B200, B300 Ram Van	70-80	RWD	N/A	N/A		■	OEMA 83160	OEMA 83160	82,82
Caliber	07-12	FWD/AWD	67455	OEMA	66		N/A	81260	79
Caravan/ Grand Caravan	01-13	AWD	N/A	N/A			N/A	81260 83170/85130	79 82/133
Caravan/ Grand Caravan w/ ABS	01-13	FWD	N/A	N/A			N/A	81260 83170/85130	79 82/133
Caravan/ Grand Caravan w/o ABS	01-13	FWD	71730*(1)	71720*(1)	72,72		N/A	81260 83170/85130	79 82/133
Caravan/ Grand Caravan	96-00	AWD	N/A	N/A			N/A	OEMA 83170/85130	82/133
Caravan/ Grand Caravan w/ ABS	96-00	FWD	N/A	N/A			N/A	OEMA 83170/85130	82/133
Caravan/ Grand Caravan w/o ABS	96-00	FWD	71730*	71720*	72,72		N/A	OEMA 83170/85130	82/133
Caravan/ Grand Caravan	90-95	AWD	N/A	N/A			N/A	OEMA 83170/85130	82/133
Caravan/ Grand Caravan	84-95	FWD	75400(1)	75400(1)	78,78		N/A	OEMA 83170/85130	82/133
Challenger	09-13	RWD	66050/66025,40920	OEMA	60/128,125		OEMA 66045	OEMA 66045	59,59
Challenger	08-08	RWD	66050/66025,40920	OEMA	60/128,125		OEMA 66040	OEMA 66040	59,59
Challenger	80-83	RWD	N/A	N/A			OEMA	N/A	
Challenger	70-74	RWD	N/A	N/A			OEMA 94450, 94451	OEMA 94450, 94451	95,95
Charger	09-13	RWD	66050/66025,40920	OEMA	60/128,125		OEMA 66045	OEMA 66045	59,59
Charger	06-13	AWD	66050/66025,40920	OEMA	60/128,125		OEMA	OEMA	
Charger	06-08	RWD	66050/66025,40920	OEMA	60/128,125		OEMA 66040	OEMA 66040	59,59
Charger	82-87	FWD	75200(1)	75200(1)	78,78		N/A	OEMA 83170/85130	82/133
Charger	66-72	RWD	N/A	N/A			OEMA 94450, 94451	OEMA 94450, 94451	95,95
Colt	93-94	FWD	OEMA	OEMA			N/A	81250	79
Colt Vista	92-94	FWD/AWD	N/A	OEMA			N/A	OEMA	
Colt Vista	84-94	4WD	N/A	OEMA			N/A	81250	79
Colt Vista	84-91	FWD/AWD	N/A	OEMA			OEMA	81250	79
Colt	80-93	FWD	N/A	N/A			N/A	81250	79
Colt	80-87	RWD	N/A	N/A			OEMA	81250	79
Conquest	84-86	RWD	N/A	OEMA			OEMA	N/A	
Coronet	65-72	RWD	N/A	N/A			OEMA 94450, 94451	OEMA 94450, 94451	95,95

ALIGNMENT FOOTNOTES BOLD PART NUMBER INDICATES PREFERRED CORRECTION METHOD

- (1) = CAUTION: Check for caliper to rotor clearance with disc brakes. Use spacer set 75970 (pg. 78) as necessary to keep caliper centered on rotor • (2) = All EXCEPT RWD 1500
 (3) = Honda S2000 Ball Joint - Rear Application - Only for 17" rims or larger • (4) = Check Bolt Length BEFORE Cutting Hole • (5) = Shims (pg. 58)
 (6) = LH Tie Rod Adjusting Sleeve Replacement (pg. 53) • (7) = Bolts, 73415, are necessary for changes greater than 3/4" (pg. 77) • (8) = Recommended for vehicles lowered more than 1.5"
 (9) = Will not work on 1988-89 models with welded-in ball joint • (10) = M3 Only, caster will decrease by 2 degrees • (11) = Pinion Angle Adj. Part No. 82370 (pg. 81)
 (12) = Limited camber range of ±1.0° • (13) = Center stock camber and toe adjusters before calculating shim change • (14) = 69330 included w/69300 or 69400 • (15) = Not for use w/disc brake
 ■ = Thrust Alignment Plate can correct thrust angle and setback (pg. 59) / Check frame angle with Angle Gauge Part No. 64225 (pg. 127)
 N/A = No Available Adjuster • OEMA = Original Equipment Manufacturer Adjustment • (*) = Series P/N, for correct size • SW = Station Wagon

©2013 Niwot Corp. dba Specialty Products Co.®

All products from Specialty Products Company are intended for use by professional installers only.



www.specprod.com

Call for your nearest distributor, product info or
 Technical Assistance • In the USA and Canada

1-800-525-6505

Applications
Parts
Heavy Duty
Racing/Off Road
Tools
Accessories
Brake & CV
Gear/Index

CAR/MINI-VAN/SUV/TRUCK APPLICATIONS

DODGE/RAM-cont.			REAR		Page	Thrust Plate	FRONT		Page
Model/Body Style	Year	Drive Type	CAMBER/TOOL	TOE/TOOL			CASTER/TOOL	CAMBER/TOOL	
D100, D150, D200, D250 Truck	72-87	RWD	N/A	N/A		■	OEMA 83160	OEMA 83160	82,82
D150, D250, D350 Truck	88-93	RWD	N/A	N/A		■	OEMA	OEMA	
D300, D350, D400, D450 Truck	72-87	RWD	N/A	N/A		■	OEMA 83160	OEMA 83160	82,82
Dakota	05-11	RWD/AWD	N/A	N/A			OEMA	OEMA	
Dakota	87-04	RWD/AWD	N/A	N/A		■	OEMA/8286, 6140	OEMA/8286	123,123 123
Dart	13-14	FWD	OEMA	OEMA			N/A	N/A	
Dart	72-76	RWD	N/A	N/A			OEMA 94460, 94461	OEMA 94460, 94461	95,95
Daytona	84-94	FWD	75200(1)	75200(1)	78,78		N/A	OEMA 83170/85130	82/133
Durango	11-14	RWD/AWD	N/A	OEMA			OEMA 82360	OEMA 82360	81,81
Durango	04-10	RWD/AWD	N/A	N/A			OEMA	OEMA	
Durango	98-03	RWD/AWD	N/A	N/A		■	OEMA/8286, 6140	OEMA/8286	123,123 123
Dynasty	88-93	FWD	75200(1)	75200(1)	78,78		N/A	OEMA 83170/85130	82/133
Intrepid (6) 55700, toe tool-Pg. 127	98-04	FWD	67080	OEMA	62		N/A	81280 82120/85130	79 81/133
Intrepid 55600, toe tool-Pg. 127	93-97	FWD	67020	OEMA	60		N/A	81280 82120/85130	79 81/133
Journey	11-13	AWD	67018	OEMA	60		N/A	81260	79
Journey	11-13	FWD	67018 75600(1)	75600(1)	60,78 78		N/A	81260	79
Journey	09-10	FWD/AWD	67015	OEMA	60		N/A	81260	79
Lancer	85-89	FWD	75200(1)	75200(1)	78,78		N/A	OEMA 83170/85130	82/133
Magnum	05-08	AWD	66050/66025,40920	OEMA	60/128,125		OEMA	OEMA	
Magnum	05-08	RWD	66050/66025,40920	OEMA	60/128,125		OEMA 66040	OEMA 66040	59,59
Monaco	90-92	FWD	75200(1)	75200(1)	78,78		N/A	81280 82120/85130	79 81/133
Neon (Inc. SRT4)	94-06	FWD	81250 67210	OEMA 67210	79 63,63		N/A	81260	79
Nitro	07-12	RWD/AWD	N/A	N/A			OEMA	OEMA	
O24	80-82	FWD	75200(1)	75200(1)	78,78		N/A	OEMA 83170/85130	82/133
Omni	78-90	FWD	75200(1)	75200(1)	78,78		N/A	OEMA 83170/85130	82/133
Ram C/V - Tradesman	12-13	AWD	N/A	N/A			N/A	81260 83170/85130	79 82/133
Ram C/V - Tradesman w/ ABS	12-13	FWD	N/A	N/A			N/A	81260 83170/85130	79 82/133
Ram C/V - Tradesman w/o ABS	12-13	FWD	71730*(1)	71720*(1)	72,72		N/A	81260 83170/85130	79 82/133
R/T	67-70	RWD	N/A	N/A			OEMA 94450, 94451	OEMA 94450, 94451	95,95
Raider	87-89	RWD/AWD	N/A	N/A		■	OEMA	OEMA	
Ramcharger	74-87	4WD	N/A	N/A			23000*/4169	23000*/4169	50/123
Ramcharger	74-87	RWD	N/A	N/A			OEMA 83160	OEMA 83160	82,82
Rampage	82-84	FWD	75200(1)	75200(1)	78,78		N/A	OEMA 83170/85130	82/133
Shadow	87-94	FWD	75200(1)	75200(1)	78,78		N/A	OEMA 83170/85130	82/133
Spirit	89-95	FWD	75200(1)	75200(1)	78,78		N/A	OEMA 83170/85130	82/133
Sprinter Van	07-13	RWD	N/A	N/A		■	N/A	35077	57
Sprinter Van	01-06	RWD	N/A	N/A		■	N/A	35075, 35076	57,57
Stealth	91-96	FWD/AWD	OEMA	OEMA			N/A	OEMA	
Stratus 4Dr.	04-06	FWD	67025	OEMA	61		N/A	67180/40920	63/125
Stratus 2Dr.	01-05	FWD	73600 73620(8) 73400+73415(7)	OEMA	77 77 77,77		N/A	81280 82120/85130	79 81/133

CAR/MINI-VAN/SUV/TRUCK APPLICATIONS

DODGE/RAM-cont.			REAR			FRONT			
Model/Body Style	Year	Drive Type	CAMBER/TOOL	TOE/TOOL	Page	Thrust Plate	CASTER/TOOL	CAMBER/TOOL	Page
Stratus 4Dr.	95-03	FWD	OEMA	OEMA			N/A	67180/ 40920	63/ 125
Super Bee	68-70	RWD	N/A	N/A			OEMA 94450, 94451	OEMA 94450, 94451	95,95
Viper	13-13	RWD	N/A	N/A			N/A	N/A	
Viper	94-10	RWD	OEMA	OEMA			OEMA	OEMA	
W100, W150, AW150 Truck	72-93	4WD	N/A	N/A		■	23000*/ 4169	23000*/ 4169	50/ 123
W200,W250 Truck	72-93	4WD	N/A	N/A		■	23000*/ 4169	23000*/ 4169	50/ 123
W300,W350 Truck w/ Dana 60	75-93	4WD	N/A	N/A		■	88940 88950 Axle Wedges	88940 88950	90,90 90,90
W300,W350 Truck	60-93	4WD	N/A	N/A			Axle Wedges	N/A	
EAGLE									
Medallion	87-89	FWD	75200(1)	75200(1)	78,78		N/A	81280 82120/ 85130	79 81/ 133
Premier	88-92	FWD	75200(1)	75200(1)	78,78		N/A	81280 82120/ 85130	79 81/ 133
Summit	89-96	FWD	N/A	N/A			N/A	81250	79
Summit SW	92-96	FWD/AWD	N/A	OEMA			N/A	81250	79
Talon	95-98	FWD/AWD	73600 73620(8) 73400+73415(7)	OEMA	77 77 77,77			67170/40920 67370(8)/ 40920	63/ 125 65/ 125
Talon	90-94	AWD	OEMA	OEMA			N/A	81250	79
Talon	90-94	FWD	N/A	N/A			N/A	81250	79
Vision <i>55600, toe tool-Pg. 127</i>	93-97	FWD	67020	OEMA	60		N/A	81280 82120/ 85130	79 81/ 133
FIAT									
500	12-13	FWD	N/A	N/A			N/A	81250	79
FORD									
Aerostar	86-97	RWD/4WD	N/A	N/A			OEMA(5)/ 87130	OEMA(5)/ 87130	134,134
Aspire	95-97	FWD	75200(1)	75200(1)	78,78		N/A	OEMA 81250	79
Bronco	80-96	4WD	N/A	N/A		■	23100*/ 77880, 88830 24130/ 74500	23100*/ 77880, 88830 24130/ 74500	50,50 131,135 55/ 129
Bronco	66-79	4WD	N/A	N/A		■	23000*/4169	23000*/4169	50/ 123
Bronco II (Late 1990) Dana 35	90-90	4WD	N/A	N/A		■	23180*/ 87175 77880, 88830 24180/ 74400, 74500	23180*/ 87175 77880, 88830 24180/ 74400, 74500	52/ 134 131,135 55/ 129, 129
Bronco II (Early 1990) Dana 28	84-90	4WD	N/A	N/A		■	23120*/ 77880, 88830 24120/ 74500	23120*/ 77880, 88830 24120/ 74500	51,51 131,135 55/ 129
Bronco II	89-90	RWD	N/A	N/A		■	23180*/ 87175 77880, 88830 24180/ 74400, 74500	23180*/ 87175 77880, 88830 24180/ 74400, 74500	52/ 134 131,135 55,55 129, 129
Bronco II	84-88	RWD	N/A	N/A		■	N/A	23160* 24160/ 74400	51 55/ 129
C-Max	10-13	FWD	OEMA	OEMA			N/A	N/A	
Contour	95-00	FWD	N/A	OEMA			89675	89675	90,90
Crown Victoria (incl. Fleet)	03-12	RWD	N/A	N/A			OEMA	OEMA 87365/ 85130, 02099	87/ 133,142
Crown Victoria (incl. Fleet)	92-02	RWD	N/A	N/A			OEMA	OEMA/ 88325	135
Crown Victoria (incl. Fleet)	80-91	RWD	N/A	N/A			OEMA	OEMA	

ALIGNMENT FOOTNOTES BOLD PART NUMBER INDICATES PREFERRED CORRECTION METHOD

- (1) = CAUTION: Check for caliper to rotor clearance with disc brakes. Use spacer set 75970 (pg. 78) as necessary to keep caliper centered on rotor • (2) = All EXCEPT RWD 1500
 (3) = Honda S2000 Ball Joint - Rear Application - Only for 17" rims or larger • (4) = Check Bolt Length BEFORE Cutting Hole • (5) = Shims (pg. 58)
 (6) = LH Tie Rod Adjusting Sleeve Replacement (pg. 53) • (7) = Bolts, 73415, are necessary for changes greater than 3/4" (pg. 77) • (8) = Recommended for vehicles lowered more than 1.5"
 (9) = Will not work on 1988-89 models with welded-in ball joint • (10) = M3 Only, caster will decrease by 2 degrees • (11) = Pinion Angle Adj. Part No. 82370 (pg. 81)
 (12) = Limited camber range of ±1.0° • (13) = Center stock camber and toe adjusters before calculating shim change • (14) = 69330 included w/69300 or 69400 • (15) = Not for use w/disc brake
 ■ = Thrust Alignment Plate can correct thrust angle and setback (pg. 59) / Check frame angle with Angle Gauge Part No. 64225 (pg. 127)
 N/A = No Available Adjuster • OEMA = Original Equipment Manufacturer Adjustment • (*) = Series P/N, for correct size • SW = Station Wagon

©2013 Niwot Corp. dba Specialty Products Co.®

All products from Specialty Products Company are intended for use by professional installers only.



www.specprod.com

Call for your nearest distributor, product info or
Technical Assistance • In the USA and Canada

1-800-525-6505

Applications
Parts
Heavy Duty
Tracing/Off Road
Tools
Accessories
Brake & CV
Gear/Index

Applications

CAR/MINI-VAN/SUV/TRUCK APPLICATIONS

FORD-cont.			REAR		Page	Thrust Plate	FRONT		Page
Model/Body Style	Year	Drive Type	CAMBER/TOOL	TOE/TOOL			CASTER/TOOL	CAMBER/TOOL	
E150	92-13	RWD	N/A	N/A		■	23180*/87175 77880, 88830 24180/ 74400, 74500 87280	23180*/87175 77880, 88830 24180/ 74400, 74500	52/134 131,135 55,55 129, 129 86
E150 w/king pins	65-90	RWD	N/A	N/A		■	N/A	N/A	
E250, E350, E450	92-13	RWD	N/A	N/A		■	23180*/87175 77880, 88830 24180/ 74400, 74500 87280(92-98 only)	23180*/87175 77880, 88830 24180/ 74400, 74500	52/134 131,135 55,55 129, 129 86
E250, E350 w/king pins	65-90	RWD	N/A	N/A		■	N/A	N/A	
EcoSport	13-13	FWD/AWD	N/A	N/A			N/A	N/A	
Edge	07-13	FWD/AWD	OEMA	OEMA			N/A	81280	79
Escape	13-14	FWD/AWD	67420	OEMA	66		N/A	N/A	
Escape incl. Hybrid	01-12	FWD/AWD	67285	OEMA	64		OEMA	OEMA 81250	79
Escort ZX2	97-04	FWD	81250	OEMA	79		OEMA	OEMA 81250	79
Escort	91-96	FWD	81250	OEMA 67070	79 62		OEMA	OEMA 81250	79
Escort	81-90	FWD	81250	OEMA	79		N/A	N/A	
Excursion	00-05	4WD	N/A	N/A		■	23130*/ 77880, 88830 24130/74500	23130*/ 77880, 88830 24130/74500	51,51 131,135 55/129
Excursion	00-05	RWD	N/A	N/A		■	23180*/87175 77880, 88830 24180/ 74400, 74500	23180*/87175 77880, 88830 24180/ 74400, 74500	52/134 131,135 55,55 129, 129
EXP	82-88	FWD	81250	OEMA	79		N/A	N/A	
Expedition	07-13	RWD/4WD	OEMA 86255 - Rear Pinion Angle	OEMA	84		OEMA 86250	OEMA 86250	84,84
Expedition	03-06	RWD/4WD	86680	OEMA	86		86640/83820	86640/83820	86/132
Expedition	97-02	RWD/4WD	N/A	N/A		■	87385	87385	87,87
Explorer	11-13	RWD/4WD	OEMA	OEMA			N/A	OEMA	
Explorer	06-10	RWD/4WD	OEMA	OEMA			OEMA	OEMA	
Explorer	02-05	RWD/4WD	86180	OEMA	84		86140	86140	84,84
Explorer	95-01	RWD/4WD	N/A	N/A		■	87310 87500	87310 87500	87,87 88,88
Explorer	91-94	RWD/4WD	N/A	N/A		■	23180*/87175 77880, 88830 24180/ 74400, 74500 87280 (RWD only)	23180*/87175 77880, 88830 24180/ 74400, 74500	52/134 131,135 55,55 129, 129 86
Explorer Sport Trac	07-10	RWD/4WD	OEMA	OEMA			OEMA	OEMA	
Explorer Sport Trac	01-05	RWD/4WD	N/A	N/A		■	87310 87500	87310 87500	87,87 88,88
F100 King Pin	65-90	RWD	N/A	N/A		■	N/A	N/A	
F100	66-79	4WD	N/A	N/A		■	23000*/4169	23000*/4169	50/123
F150	04-13	4WD	N/A	N/A			OEMA 86250	OEMA 86250	84,84
<i>JounceShock System Avail.-Pg. 120</i>									
F150	04-13	RWD	N/A 86255 - Rear Pinion Angle	N/A	84		OEMA 86250	OEMA 86250	84,84
F150 Heritage	04-05	4WD/RWD	N/A	N/A		■	87385	87385	87,87
F150	97-03	4WD/RWD	N/A	N/A		■	87385	87385	87,87
F150	87-96	4WD	N/A	N/A		■	23100*/ 77880, 88830 24130/74500	23100*/ 77880, 88830 24130/74500	50,50 131,135 55/129
F150	87-96	RWD	N/A	N/A		■	23180*/87175 77880, 88830 24180/ 74400, 74500 87280	23180*/87175 77880, 88830 24180/ 74400, 74500	52/134 131,135 55,55 129, 129 86
F150 King Pin	65-90	RWD	N/A	N/A		■	N/A	N/A	
F150	82-86	RWD	N/A	N/A		■	N/A	23160* 24160/74400	51 55/129
F150	80-86	4WD	N/A	N/A		■	23100*/ 77880, 88830 24130/74500	23100*/ 77880, 88830 24130/74500	50,50 131,135 55/129
F150	66-79	4WD	N/A	N/A		■	23000*/4169	23000*/4169	50/123

CAR/MINI-VAN/SUV/TRUCK APPLICATIONS

FORD-cont.			REAR		Page	Thrust Plate	FRONT		Page
Model/Body Style	Year	Drive Type	CAMBER/TOOL	TOE/TOOL			CASTER/TOOL	CAMBER/TOOL	
F250 Solid Axle - Coil Spring	05-13	RWD/4WD	N/A	N/A		■	23220* 23268 23269 24220	23220* 23268 23269 24220	52,52 52,52 52,52 55,55
F250 Solid Axle - Leaf Spring	99-04	RWD/4WD	N/A	N/A		■	23130*/ 77880, 88830 24130/74500	23130*/ 77880, 88830 24130/74500	51,51 131,135 55/129
F250 Twin I-Beam	98-13	RWD	N/A	N/A		■	23180*/ 87175 77880, 88830 24180/ 74400, 74500	23180*/ 87175 77880, 88830 24180/ 74400, 74500	52/134 131,135 55,55 129, 129
F250 L/D	97-99	RWD/4WD	N/A	N/A		■	87385	87385	87,87
F250	87-98	RWD	N/A	N/A		■	23180*/ 87175 77880, 88830 24180/ 74400, 74500 87280(92-96 only)	23180*/ 87175 77880, 88830 24180/ 74400, 74500	52/134 131,135 55,55 129, 129 86
F250	80-98	4WD	N/A	N/A		■	23100*/ 77880, 88830 24130/74500	23100*/ 77880, 88830 24130/74500	50,50 131,135 55/129
F250 King Pin	65-90	RWD	N/A	N/A		■	N/A	N/A	
F250	82-86	RWD	N/A	N/A		■	N/A	N/A	
F250 Dana 60	74-79	4WD	N/A	N/A		■	88940 88950	88940 88950	90,90 90,90
F250	73-79	4WD	N/A	N/A		■	23000*/ 4169 Axle Wedges	23000*/ 4169	50/123
F350 Solid Axle - Coil Spring <i>JounceShock System Avail.-Pg. 120</i>	05-13	RWD/4WD	N/A	N/A		■	23220* 24268 23269 24220	23220* 24268 23269 24220	52,52 52,52 52,52 55,55
F350 Solid Axle - Leaf Spring	99-04	RWD/4WD	N/A	N/A		■	23130*/ 77880, 88830 24130/74500	23130*/ 77880, 88830 24130/74500	51,51 131,135 55/129
F350 Twin I-Beam	98-13	RWD	N/A	N/A		■	23180*/ 87175 , 77880, 88830 24180/ 74400, 74500	23180*/ 87175 , 77880, 88830 24180/ 74400, 74500	52/134 131,135 55,55 129, 129
F350 Crew Cab	92-98	4WD	N/A	N/A		■	23130*/ 77880, 88830 24130/74500	23130*/ 77880, 88830 24130/74500	51,51 131,135 55/129
F350	87-98	RWD	N/A	N/A		■	23180*/ 87175 , 77880, 88830 24180/ 74400, 74500 87280(92-96 only)	23180*/ 87175 , 77880, 88830 24180/ 74400, 74500	52/134 131,135 55,55 129, 129 86
F350	80-98	4WD	N/A	N/A		■	23100*/ 77880, 88830 24130/74500	23100*/ 77880, 88830 24130/74500	50,50 131,135 55/129
F350 King Pin	65-90	RWD	N/A	N/A		■	N/A	N/A	
F350	82-86	RWD	N/A	N/A		■	N/A	N/A	
F350 Dana 60	74-91	4WD	N/A	N/A		■	88940 88950	88940 88950	90,90 90,90
F350	73-79	4WD	N/A	N/A		■	Axle Wedges	N/A	
F450	05-13	RWD/4WD	N/A	N/A		■	23230* 24230	23230* 24230	52,52 55,55
F450	99-04	RWD/4WD	N/A	N/A		■	23130*/ 77880, 88830 24130/74500	23130*/ 77880, 88830 24130/74500	51,51 131,135 55/129
F550	05-13	RWD/4WD	N/A	N/A		■	23230* 24230	23230* 24230	52,52 55,55
F550	99-04	RWD/4WD	N/A	N/A		■	23130*/ 77880, 88830 24130/74500	23130*/ 77880, 88830 24130/74500	51,51 131,135 55/129

ALIGNMENT FOOTNOTES BOLD PART NUMBER INDICATES PREFERRED CORRECTION METHOD

- (1) = CAUTION: Check for caliper to rotor clearance with disc brakes. Use spacer set 75970 (pg. 78) as necessary to keep caliper centered on rotor • (2) = All EXCEPT RWD 1500
 (3) = Honda S2000 Ball Joint - Rear Application - Only for 17" rims or larger • (4) = Check Bolt Length BEFORE Cutting Hole • (5) = Shims (pg. 58)
 (6) = LH Tie Rod Adjusting Sleeve Replacement (pg. 53) • (7) = Bolts, 73415, are necessary for changes greater than 3/4" (pg. 77) • (8) = Recommended for vehicles lowered more than 1.5"
 (9) = Will not work on 1988-89 models with welded-in ball joint • (10) = M3 Only, caster will decrease by 2 degrees • (11) = Pinion Angle Adj. Part No. 82370 (pg. 81)
 (12) = Limited camber range of ±1.0° • (13) = Center stock camber and toe adjusters before calculating shim change • (14) = 69330 included w/69300 or 69400 • (15) = Not for use w/disc brake
 ■ = Thrust Alignment Plate can correct thrust angle and setback (pg. 59) / Check frame angle with Angle Gauge Part No. 64225 (pg. 127)
 N/A = No Available Adjuster • OEMA = Original Equipment Manufacturer Adjustment • (*) = Series P/N, for correct size • SW = Station Wagon

©2013 Niwot Corp. dba Specialty Products Co.®

All products from Specialty Products Company are intended for use by professional installers only.



www.specprod.com

Call for your nearest distributor, product info or
Technical Assistance • In the USA and Canada

1-800-525-6505

Applications
Parts
Heavy Duty
Racing/Off Road
Tools
Accessories
Brake & CV
Gear/Index

CAR/MINI-VAN/SUV/TRUCK APPLICATIONS

FORD-cont.			REAR		Page	Thrust Plate	FRONT		Page
Model/Body Style	Year	Drive Type	CAMBER/TOOL	TOE/TOOL			CASTER/TOOL	CAMBER/TOOL	
Fairlane	66-70	RWD	N/A	N/A			OEMA	OEMA 83160	82
Fairmont	78-83	RWD	N/A	N/A			N/A	OEMA 81280 82120/ 85130	79 81/ 133
Falcon	66-70	RWD	N/A	N/A			OEMA	OEMA 83160	82
Falcon	60-65	RWD	N/A	N/A			OEMA(5)	OEMA(5)	
Festiva	88-94	FWD	75200(1)	75200(1)	78,78		N/A	OEMA 81250	79
Fiesta	11-13	FWD	N/A	N/A			N/A	81250	79
Fiesta	78-80	FWD	N/A	N/A			N/A	N/A	
Five Hundred	05-07	FWD/AWD	N/A	OEMA			N/A	OEMA	
Flex	09-13	FWD/AWD	OEMA	OEMA			N/A	OEMA	
Focus	11-13	FWD	67420 81310	OEMA	66 80		N/A	OEMA	
Focus	00-10	FWD	67420 81310	OEMA	66 80		81320	81320	80,80
Freestar	04-07	FWD	N/A	N/A			OEMA	OEMA/ 85790 89685	133 90,90
Freestyle	05-07	FWD/AWD	N/A	OEMA			N/A	OEMA	
Fusion incl. Hybrid	13-13	FWD/AWD	OEMA	OEMA			N/A	N/A	
Fusion incl. Hybrid	06-12	FWD/AWD	OEMA	OEMA			N/A	67115/ 40920	63/ 123
Granada	81-82	RWD	N/A	N/A			N/A	OEMA 81280 82120/ 85130	79 81/ 133
Granada	75-80	RWD	N/A	N/A			OEMA	OEMA 83160	82
LTD	83-86	RWD	N/A	N/A			N/A	OEMA 81280 82120/ 85130	79 81/ 133
Maverick	69-77	RWD	N/A	N/A			OEMA	OEMA 83160	82
Mustang	12-13	RWD	N/A	72045 72345	73 77		72355 72350	81260 72350	77,79 77,77
Mustang	05-11	RWD	N/A	72045 72345	73 77		72040 72355 72350	81260 72040 72350	73,79 77,73 77,77
Mustang	94-04	RWD	N/A	N/A			72060	OEMA 72060 81280 82120/ 85130	73 73 79 81/ 133
Mustang	79-93	RWD	N/A	N/A			N/A	OEMA 81280 82120/ 85130	79 81/ 133
Mustang II	74-78	RWD	N/A	N/A			OEMA 94800 93040, 93050	OEMA 94800	91,91 91,91
Mustang	67-73	RWD	N/A	N/A			OEMA	OEMA 83160	82
Mustang	64-66	RWD	N/A	N/A			OEMA(5)	OEMA(5)	
Mustang Cobra	99-04	RWD	OEMA	OEMA			OEMA/ 85130 72060	OEMA 72060 81280 82120/ 85130	133 73,73 79 81/ 133
Probe	89-97	FWD	81250	OEMA	79		OEMA	OEMA 81250	79
Ranger	01-12	RWD/4WD	N/A	N/A			■ 87500	87500	88,88
Ranger	98-00	RWD/4WD	N/A	N/A			■ 87310 87500	87310 87500	87,87 88,88
Ranger Dana 35	90-97	RWD/4WD	N/A	N/A			■ 23180*/ 87175 77880, 88830 24180/ 74400, 74500 87280 (RWD Only)	23180*/ 87175 77880, 88830 24180/ 74400, 74500	52/ 134 131,135 55,55 129, 129 86
Ranger Dana 28	83-89	4WD	N/A	N/A			■ 23120*/ 77880 24120/ 74500	23120*/ 77880 24120/ 74500	51/ 131 55/ 123
Ranger	83-88	RWD	N/A	N/A			■ N/A	23160* 24160/ 74400	51 55/ 123
Taurus	10-13	FWD/AWD	OEMA	OEMA			N/A	OEMA	

Applications
Parts
Heavy Duty
Racing/Off Road
Tools
Accessories
Brake & CV
Gear/Index

CAR/MINI-VAN/SUV/TRUCK APPLICATIONS

FORD-cont.			REAR			FRONT			
Model/Body Style	Year	Drive Type	CAMBER/TOOL	TOE/TOOL	Page	Thrust Plate	CASTER/TOOL	CAMBER/TOOL	Page
Taurus	08-09	FWD/AWD	N/A	OEMA			N/A	OEMA	
Taurus Sedan	96-07	FWD	87330/ 8370 , 87320	OEMA/ 87325 87330/ 8370, 87320	87/ 123,134 134 87 123,134		OEMA/ 85790	OEMA/ 85790 89635	133,133 90
Taurus Wagon	96-05	FWD	87350/ 85130	OEMA/ 97650	87/ 133,135		OEMA/ 85790	OEMA/ 85790 89635	133,133 90
Taurus Sedan	86-95	FWD	87330/ 8370 , 87320	OEMA/ 87325 87330/ 8370, 87320	87/ 123,134 134 87 123,134		OEMA/ 85790	OEMA/ 85790	133,133
Taurus Wagon	86-95	FWD	87350/ 85130	OEMA/ 97650	87/ 133,135		OEMA/ 85790	OEMA/ 85790	133,133
Taurus X	08-09	FWD/AWD	N/A	OEMA			N/A	OEMA	
Tempo	86-94	FWD/4WD	81250	OEMA/ 87325	79/ 134		N/A	N/A	
Tempo	84-85	FWD	81250	N/A	79		N/A	N/A	
Thunderbird	02-06	RWD	N/A	OEMA			OEMA 87540	OEMA 87540	89,89
Thunderbird	89-97	RWD	OEMA	OEMA			OEMA	OEMA 87535	89
Thunderbird	80-88	RWD	N/A	N/A			N/A	OEMA 81280 82120/ 85130	79 81/ 133
Thunderbird	64-66	RWD	N/A	N/A			47142, 47143	47142, 47143	58,58
Torino	66-71	RWD	N/A	N/A			OEMA	OEMA 83160	82
Transit Connect	10-13	FWD	N/A	N/A			N/A	N/A	
Windstar	94-03	FWD	75400(1)	75400(1)	78,78		OEMA	OEMA/ 85790 89685	133 90

FREIGHTLINER

See our HeavyDuty	Section	pages 101-111							
Sprinter Van	07-13	RWD	N/A	N/A			N/A	35077	57
Sprinter Van	01-06	RWD	N/A	N/A			N/A	35075, 35076	57,57

GEO

Metro/M	89-97	FWD	N/A	OEMA			N/A	81250	79
Prizm/S	89-97	FWD	75600 or 75800(1)	75600 or 75800(1)	78,78			81260	79
Spectrum/R	89-90	FWD	75200(1)	75200(1)	78,78		N/A	81250	79
Storm	90-93	FWD	81250	OEMA	79		N/A	81250	79
Tracker	89-97	RWD/4WD	N/A	N/A			N/A	81250	79

GMC

See Chevrolet/GMC	Section	pages 12-16							
-------------------	---------	-------------	--	--	--	--	--	--	--

HONDA

Accord	13-13	FWD	67540 67545(12)	OEMA 67540 67550 67555	68 68,68 68 68		N/A	OEMA	
Accord	08-12	FWD	67540 67545(12)	OEMA 67540 67550 67555	68 68,68 68 68		N/A	67135/40920 67330(8)/ 40920	63, 125 65, 125
Accord	03-07	FWD	67290	OEMA	65		N/A	67135/40920 67330(8)/ 40920	63, 125 65, 125
Accord 67075 Repl. Front Ball Joint-Pg. 62	98-02	FWD	67090	OEMA	62		84690, 84695	67125/40920 67320(8)/ 40920	83,63, 125 65, 125
Accord 67075 Repl. Front Ball Joint-Pg. 62	90-97	FWD	67065 67265(8)	OEMA	61 64		84690, 84695	67145/40920 67340(8)/ 40920	83,63, 125 65, 125
Accord	86-89	FWD	67395	OEMA	65		OEMA	N/A	
Accord	80-85	FWD	N/A	OEMA			N/A	N/A	
Accord Crosstour	10-12	FWD	67540 67545(12)	OEMA 67540 67550 67555	68 68,68 68 68		N/A	67135/40920 67330(8)/ 40920	63, 125 65, 125

ALIGNMENT FOOTNOTES BOLD PART NUMBER INDICATES PREFERRED CORRECTION METHOD

- (1) = CAUTION: Check for caliper to rotor clearance with disc brakes. Use spacer set 75970 (pg. 78) as necessary to keep caliper centered on rotor • (2) = All EXCEPT RWD 1500
 (3) = Honda S2000 Ball Joint - Rear Application - Only for 17" rims or larger • (4) = Check Bolt Length BEFORE Cutting Hole • (5) = Shims (pg. 58)
 (6) = LH Tie Rod Adjusting Sleeve Replacement (pg. 53) • (7) = Bolts, 73415, are necessary for changes greater than 3/4" (pg. 77) • (8) = Recommended for vehicles lowered more than 1.5"
 (9) = Will not work on 1988-89 models with welded-in ball joint • (10) = M3 Only, caster will decrease by 2 degrees • (11) = Pinion Angle Adj. Part No. 82370 (pg. 81)
 (12) = Limited camber range of ±1.0° • (13) = Center stock camber and toe adjusters before calculating shim change • (14) = 69330 included w/69300 or 69400 • (15) = Not for use w/disc brake
 ■ = Thrust Alignment Plate can correct thrust angle and setback (pg. 59) / Check frame angle with Angle Gauge Part No. 64225 (pg. 127)
 N/A = No Available Adjuster • OEMA = Original Equipment Manufacturer Adjustment • (*) = Series P/N, for correct size • SW = Station Wagon

©2013 Niwot Corp. dba Specialty Products Co.®

All products from Specialty Products Company are intended for use by professional installers only.



www.specprod.com

Call for your nearest distributor, product info or
Technical Assistance • In the USA and Canada

1-800-525-6505

Applications
Parts
Heavy Duty
Tools
Accessories
Gear/Index

Applications

CAR/MINI-VAN/SUV/TRUCK APPLICATIONS

HONDA-cont.			REAR			Thrust Plate	FRONT		Page
Model/Body Style	Year	Drive Type	CAMBER/TOOL	TOE/TOOL	Page		CASTER/TOOL	CAMBER/TOOL	
Civic/Hybrid	12-13	FWD	67470 67465/ 75980,72509	OEMA/ 87560	67/ 134 67/ 131,129		N/A	81280	79
Civic Si	12-13	FWD	67470 67465/ 75980,72509	OEMA/ 87560	67/ 134 67/ 131,129		N/A	81290	79
Civic/Hybrid	06-11	FWD	67470 67465/ 75980,72509	OEMA/ 87560	67/ 134 67/ 131,129		N/A	81260	79
Civic Si	06-11	FWD	67470 67465/ 75980,72509	OEMA/ 87560	67/ 134 67/ 131,129		N/A	81280	79
Civic/Hybrid	03-05	FWD	67230 69300 (Lower Arm) / 69330(14)	OEMA	64 71 128		N/A	81280	79
Civic	01-02	FWD	67230 69300 (Lower Arm) / 69330(14)	OEMA	64 71 128		N/A	81260	79
Civic 67075 Repl. Front Ball Joint-Pg. 62 65100 Rear Trailing Arm Bushing Ext	96-00	FWD	67030 69100 (Lower Arm)	OEMA 69250 69450	61 71,71 71		62010	62010 67135/40920 67330(8)/ 40920	59.59 63/ 125 65/ 125
Civic 67245 Repl. Front Ball Joint-Pg. 64 65100 Rear Trailing Arm Bushing Ext	92-95	FWD	67030 69200 (Lower Arm)	OEMA 69250 69450	61 71,71 71			67135/40920 67330(8)/ 40920	63/ 125 65/ 125
Civic 67075 Repl. Front Ball Joint-Pg. 62 65100 Rear Trailing Arm Bushing Ext	88-91	FWD	67030 69200 (Lower Arm)	OEMA 69250 69460	61 71,71 71		N/A	67125/40920(9) 67320(8)/ 40920(9)	63/ 125 65/ 125
Civic	80-87	FWD	N/A	N/A			N/A	N/A	
Civic SW & 4WD	88-91	FWD/4WD	67030 69200 (Lower Arm)	OEMA	61 71		N/A	67125/40920(9) 67320(8)/ 40920(9)	63/ 125 65/ 125
CR-V	07-13	FWD/AWD	67580	OEMA/ 87560	69/ 134		N/A	81280	79
CR-V	02-06	FWD/AWD	67430 69400 (Lower Arm) / 69330(14)	OEMA	66 71 128		N/A	81280	79
CR-V 67245 Repl. Front Ball Joint-Pg. 64	97-01	FWD/AWD	67030	OEMA	61		N/A	67135/40920 67330(8)/ 40920	63/ 125 65/ 125
CRX 67075 Repl. Front Ball Joint-Pg. 62 65100 Rear Trailing Arm Bushing Ext	88-92	FWD	67030 69200 (Lower Arm)	OEMA 69250 67460	61 71,71 71		N/A	67125/40920(9) 67320(8)/ 40920(9)	63/ 125 65/ 125
CRX	84-86	FWD	N/A	N/A			N/A	N/A	
CR-Z	11-13	FWD	N/A	N/A			N/A	81260	79
Del Sol 67075 Repl. Front Ball Joint-Pg. 62 65100 Rear Trailing Arm Bushing Ext	92-97	FWD	67030 69200 (Lower Arm)	OEMA 69250 69450	61 71,71 71		N/A	67135/40920 67330(8)/ 40920	63/ 125 65/ 125
Element (Except SC)	03-11	FWD/AWD	67430 69400 (Lower Arm) / 69330(14)	OEMA/ 87560	66/ 134 71 128		N/A	81280	79
Fit	09-13	FWD	N/A	N/A			N/A	81260	79
Fit	06-08	FWD	75600 or 75800(1)	75600 or 75800(1)	78,78		N/A	81260	79
Insight	10-13	FWD	N/A	N/A			N/A	81260	79
Insight	01-06	FWD	N/A	N/A			N/A	81260	79
Odyssey/Touring Elite	05-13	FWD	67590	OEMA	69		N/A	81280	79
Odyssey	99-04	FWD	67290	OEMA	65		N/A	81280	79
Odyssey 67075 Repl. Front Ball Joint-Pg. 62	95-98	FWD	67155/ 40920	OEMA	63/ 125		OEMA 84690, 84695	67145/40920 67340(8)/ 40920	63/ 125 83.65/ 125
PassPort	94-02	FWD/AWD	N/A	N/A			OEMA(5)	OEMA(5)	
Pilot	09-13	FWD/AWD	67570	OEMA	69		N/A	81290	79
Pilot	03-08	FWD/AWD	67290	OEMA	65		N/A	81280	79
Prelude SH	97-02	FWD	67165/40920 67360(8)/ 40920	OEMA	63/ 125 65/ 125		N/A	67155/40920 67350(8)/ 40920	63/ 125 65/ 125
Prelude 67245 Repl. Front Ball Joint-Pg. 64	97-02	FWD	67165/40920 67360(8)/ 40920	OEMA	63/ 125 65/ 125		N/A	67135/40920 67330(8)/ 40920	63/ 125 65/ 125
Prelude	92-96	FWD	67165/40920 67360(8)/ 40920	OEMA	63/ 125 65/ 125		N/A	67165/40920 67360(8)/ 40920	63/ 125 65/ 125
Prelude 4WS	92-94	FWD	OEMA	OEMA			OEMA	67165/40920 67360(8)/ 40920	63/ 125 65/ 125
Prelude 4WS	88-91	FWD	OEMA	OEMA			OEMA	OEMA	
Prelude	83-91	FWD	N/A	OEMA			OEMA	OEMA	
Prelude	79-82	FWD	N/A	N/A			OEMA	N/A	
Ridgeline	06-13	FWD/AWD	67490	OEMA	67		N/A	81290	79
S2000	00-09	RWD	OEMA 67220(3)/ 40920	OEMA	64/ 125		OEMA	OEMA 67220/ 40920	64/ 125

CAR/MINI-VAN/SUV/TRUCK APPLICATIONS

HUMMER			REAR			FRONT			
Model/Body Style	Year	Drive Type	CAMBER/TOOL	TOE/TOOL	Page	Thrust Plate	CASTER/TOOL	CAMBER/TOOL	Page
H1	92-06	4WD	OEMA	OEMA			OEMA	OEMA	
H2, H2 SUT	02-09	AWD	N/A	N/A			OEMA 86320 86325, 86375 23960/ 72509	OEMA 86330/ 72509, 79500 86320, 86325, 86375 23960/ 72509	85/ 129,131 85,85,86,86 54/ 129
H3, H3T <i>JounceShock System Avail.-Pg. 120</i>	06-10	AWD	N/A	N/A		■	OEMA/ 45940 86360/ 45938 86320, 86325, 86375	OEMA/ 45940 86360/ 45938 86320, 86325, 86375	127,127 85/ 127 85,85,86 85,86
HYUNDAI									
Accent	12-13	FWD	N/A	N/A			N/A	81250	79
Accent	06-11	FWD	75600 or 75800(1)	75600 or 75800(1)	78,78		N/A	81250	79
Accent	95-05	FWD	81250	OEMA	79		N/A	81250	79
Azera	12-13	FWD	N/A	N/A			N/A	N/A	
Azera after 10/31/06	07-11	FWD	OEMA	OEMA			N/A	67195/ 40920	63/ 125
Azera before 10/31/06	06-06	FWD	OEMA	OEMA			N/A	67190/ 40920	63/ 125
Elantra Coupe w/Beam Type Rear Susp.	13-13	FWD	N/A	N/A			N/A	81260	79
Elantra GT w/Multi-Link Rear Susp.	13-13	FWD	67410	OEMA 67410/ 85130	66 66/ 133		N/A	81260	79
Elantra after 7-1-2011 w/Beam Type Rear Susp.	11-13	FWD	N/A	N/A			N/A	81280	79
Elantra Touring w/Multi-Link Rear Susp.	11-12	FWD	67410	OEMA 67410/ 85130	66 66/ 133		N/A	81260	79
Elantra w/Beam Type Rear Susp.	11-13	FWD	N/A	N/A			N/A	81260	79
Elantra before 7/1/11 w/Beam Type Rear Susp.	11-11	FWD	N/A	N/A			N/A	81260	79
Elantra w/Multi-Link Rear Susp.	07-10	FWD	67410	OEMA 67410/ 85130	66 66/ 133		N/A	81260	79
Elantra	97-06	FWD	81250	OEMA	79		N/A	81250	79
Elantra	92-96	FWD	N/A	N/A			N/A	81250	79
Entourage	07-09	FWD	N/A	OEMA			N/A	81250	79
Equus	11-13	RWD	OEMA	OEMA			N/A	N/A	
Excel	90-94	FWD	N/A	N/A			N/A	81250	79
Excel	86-89	FWD	N/A	N/A			OEMA	81250	79
Genesis Sedan	09-13	RWD/AWD	OEMA	OEMA			N/A	N/A	
Genesis Coupe	10-13	RWD	OEMA	OEMA			N/A	81260	79
Pony	83-87	RWD	N/A	N/A			OEMA	N/A	
Sante Fe	13-13	FWD/AWD	N/A	N/A			N/A	N/A	
Sante Fe	01-12	FWD/AWD	OEMA	OEMA			N/A	81260	79
Scoupe	90-95	FWD	N/A	N/A			N/A	81250	79
Sonata after 5/2011	11-13	FWD	N/A	OEMA			N/A	81280	79
Sonata before 5/2011	11-11	FWD	N/A	OEMA			N/A	81260	79
Sonata after 9/21/06	07-10	FWD	OEMA	OEMA			N/A	67195/ 40920	63/ 125
Sonata before 9/21/06	99-06	FWD	N/A	OEMA			N/A	67190/ 40920	63/ 125
Sonata	95-98	FWD	OEMA	OEMA			N/A	81260	79
Sonata	89-94	FWD	N/A	N/A			N/A	81260	79
Stellar	84-88	FWD	N/A	N/A			OEMA	N/A	
Tiburon	03-09	FWD	81250	OEMA	79		N/A	81260	79
Tiburon	97-02	FWD	81250	OEMA	79		OEMA	81250	79
Tuscon	05-13	FWD/AWD	81260	OEMA	79		N/A	81260	79
Veloster	12-13	FWD	75600(1)	75600(1)	78,78		N/A	81260	79
Veracruz	07-12	AWD	OEMA	OEMA			N/A	81260	79
XG300-XG350	01-06	FWD	N/A	OEMA			N/A	67190/ 40920	63/ 125

ALIGNMENT FOOTNOTES BOLD PART NUMBER INDICATES PREFERRED CORRECTION METHOD

- (1) = CAUTION: Check for caliper to rotor clearance with disc brakes. Use spacer set 75970 (pg. 78) as necessary to keep caliper centered on rotor • (2) = All EXCEPT RWD 1500
 (3) = Honda S2000 Ball Joint - Rear Application - Only for 17" rims or larger • (4) = Check Bolt Length BEFORE Cutting Hole • (5) = Shims (pg. 58)
 (6) = LH Tie Rod Adjusting Sleeve Replacement (pg. 53) • (7) = Bolts, 73415, are necessary for changes greater than 3/4" (pg. 77) • (8) = Recommended for vehicles lowered more than 1.5"
 (9) = Will not work on 1988-89 models with welded-in ball joint • (10) = M3 Only, caster will decrease by 2 degrees • (11) = Pinion Angle Adj. Part No. 82370 (pg. 81)
 (12) = Limited camber range of ±1.0° • (13) = Center stock camber and toe adjusters before calculating shim change • (14) = 69330 included w/69300 or 69400 • (15) = Not for use w/disc brake
 ■ = Thrust Alignment Plate can correct thrust angle and setback (pg. 59) / Check frame angle with Angle Gauge Part No. 64225 (pg. 127)
 N/A = No Available Adjuster • OEMA = Original Equipment Manufacturer Adjustment • (*) = Series P/N, for correct size • SW = Station Wagon

©2013 Niwot Corp. dba Specialty Products Co.®

All products from Specialty Products Company are intended for use by professional installers only.



www.specprod.com

Call for your nearest distributor, product info or
Technical Assistance • In the USA and Canada

1-800-525-6505

Applications
Parts
Heavy Duty
Racing/Off Road
Tools
Accessories
Brake & CV
Gear/Index

Applications

CAR/MINI-VAN/SUV/TRUCK APPLICATIONS

INFINITI			REAR			FRONT			
Model/Body Style	Year	Drive Type	CAMBER/TOOL	TOE/TOOL	Page	Thrust Plate	CASTER/TOOL	CAMBER/TOOL	Page
EX37	13-14	FWD/AWD	N/A	N/A			N/A	N/A	
EX35	08-12	FWD/AWD	OEMA	OEMA			72130	72130	75,75
FX35	13-14	FWD/AWD	OEMA	OEMA			N/A	N/A	
FX35	09-12	FWD/AWD	OEMA	OEMA			N/A	N/A	
FX35	03-08	FWD/AWD	OEMA 72265/ 85130	OEMA 72265/ 85130	76/ 133		N/A	81260	79
FX45	03-08	FWD/AWD	OEMA 72265/ 85130	OEMA 72265/ 85130	76/ 133		N/A	81260	79
FX50	09-12	FWD/AWD	OEMA	OEMA			N/A	N/A	
G20	97-02	FWD	N/A	N/A			N/A	N/A	
G20	91-96	FWD	81250	OEMA			N/A	N/A	
G25 Sedan	11-12	RWD	OEMA 72280/ 85130 72265/ 85130	OEMA 72280/ 85130 72265/ 85130	76/ 133 76/ 133		72130	72130	75,75
G35 Sedan Inc. active steer	07-08	RWD/AWD	OEMA 72260/ 85130 72265/ 85130	OEMA 72260/ 85130 72265/ 85130	76/ 133 76/ 133		72130	72130	75,75
G35 Coupe w/ rear active steer	06-07	RWD/AWD	OEMA 72260/ 85130 72265/ 85130	OEMA 72260/ 85130 72265/ 85130	76/ 133 76/ 133		72125/ 8370	72125/ 8370	74/ 123
G35 Coupe w/o rear active steer	03-07	RWD/AWD	OEMA 72050/ 85130 72055/ 85130	OEMA 72050/ 85130 72055/ 85130	73/ 133 73/ 133		72125/ 8370	72125/ 8370	74/ 123
G35 Sedan	03-06	RWD/AWD	OEMA 72050/ 85130 72055/ 85130	OEMA 72050/ 85130 72055/ 85130	73/ 133 73/ 133		72125/ 8370	72125/ 8370	74/ 123
G37 Convertible	09-13	RWD/AWD	OEMA	OEMA			72130	72130	75,75
G37 Sedan	09-13	RWD/AWD	OEMA 72280/ 85130 72265/ 85130	OEMA 72280/ 85130 72265/ 85130	76/ 133 76/ 133		72130	72130	75,75
G37 Coupe incl. active steer	08-13	RWD/AWD	OEMA 72260/ 85130 72265/ 85130	OEMA 72260/ 85130 72265/ 85130	76/ 133 76/ 133		72130	72130	75,75
I30	95-01	FWD	N/A	OEMA			N/A	81260	79
I35	02-05	FWD	N/A	OEMA			N/A	81260	79
J30	92-97	RWD	N/A	OEMA			N/A	N/A	
JX	13-13	FWD/AWD	N/A	N/A			N/A	N/A	
M30	90-92	RWD	N/A	OEMA			N/A	N/A	
M35, M45	06-10	RWD/AWD	OEMA 72280/ 85130 72265/ 85130	OEMA 72280/ 85130 72265/ 85130	76/ 133 76/ 133		72130	72130	75,75
M35, M45	03-05	RWD/AWD	OEMA	OEMA			N/A	N/A	
M37, M56	11-13	RWD/AWD	N/A	N/A			N/A	N/A	
Q45	90-07	RWD	OEMA	OEMA			N/A	N/A	
QX4	97-03	RWD/4WD	N/A	N/A			N/A	81260	79
QX56	05-13	FWD/AWD	N/A	N/A			OEMA 87520	OEMA 87520	88,88

INTERNATIONAL										
Pickup	72-75	4WD	N/A	N/A			■	23000*/ 4169	23000*/ 4169	50/ 123
Pickup (1300)	60-71	4WD	N/A	N/A			■	88940 88950	88940 88950	90,90 90,90
Scout II	73-80	4WD	N/A	N/A			■	23000*/ 4169	23000*/ 4169	50/ 123
Scout	61-71	4WD	N/A	N/A				Axle Wedges	N/A	

INTERNATIONAL HARVESTER CORP (IHC)

See our HeavyDuty Section pages 101-111

ISUZU										
Amigo	90-00	RWD/4WD	N/A	N/A				OEMA(5)	OEMA(5)	
Ascender	03-07	RWD/AWD	N/A	N/A				OEMA/ 83785	OEMA/ 83785	132
Axiom	02-04	AWD	N/A	N/A				OEMA(5)	OEMA(5)	
i-280/290	06-08	RWD	N/A	N/A				OEMA	OEMA	
i-350/370	06-08	4WD	N/A	N/A				OEMA/ 45940 86360/ 45938 86320, 86325, 86375	OEMA/ 45940 86360/ 45938 86320, 86325, 86375	127,127 85,127 85,85,86 85,86
I-Mark	85-89	FWD	75200(1)	75200(1)	78,78			N/A	81250	79

Applications
Parts
Heavy Duty
Racing/Off Road
Tools
Accessories
Brake & CV
Gear/Index

CAR/MINI-VAN/SUV/TRUCK APPLICATIONS

ISUZU-cont.			REAR			FRONT			
Model/Body Style	Year	Drive Type	CAMBER/TOOL	TOE/TOOL	Page	Thrust Plate	CASTER/TOOL	CAMBER/TOOL	Page
Impulse	90-93	FWD/AWD	81250	OEMA	79		N/A	81250	79
Impulse	83-89	RWD	N/A	N/A			OEMA	OEMA	
Hombre	97-98	4WD	N/A	N/A		■	OEMA 83710	OEMA 83710	83,83
Oasis	96-99	FWD	67155/ 40920	OEMA	63/ 125		OEMA	67145/40920 67340(8)/ 40920	63/ 125 65/ 125
Pickup	81-99	RWD/4WD	N/A	N/A			OEMA(5)	OEMA(5)	
Rodeo	91-03	RWD/4WD	N/A	N/A			OEMA(5)	OEMA(5)	
Rodeo Sport	01-03	RWD/4WD	N/A	N/A			OEMA(5)	OEMA(5)	
Stylus	91-94	FWD	81250	OEMA	79		OEMA	81250	79
Trooper	81-02	RWD/4WD	N/A	N/A			OEMA(5)	OEMA(5)	
Vehi'Cross	00-01	4WD	N/A	N/A			OEMA(5)	OEMA(5)	
JAGUAR									
S Type	03-08	RWD	N/A	OEMA			OEMA	OEMA	
S Type	00-02	RWD	N/A	OEMA			OEMA 87540	OEMA 87540	89,89
X-Type	02-11	FWD/AWD	N/A	OEMA			N/A	N/A	
XF	09-13	RWD	N/A	N/A			N/A	N/A	
XJ	10-13	RWD	N/A	OEMA			OEMA	OEMA	
XJR, XJB	97-12	RWD	N/A	OEMA			N/A	N/A	
XK8, XKR	02-13	RWD	N/A	OEMA			N/A	N/A	
JEEP									
Cherokee (XJ)	84-01	RWD/4WD	N/A	N/A			23510-23540/ 23580, 72509 47240-47242	23510-23540/ 23580, 72509	53,53 123,129 59
Cherokee (SJ)	74-83	4WD	N/A	N/A		■	23000*/ 4169	23000*/ 4169	50/ 123
CJ	72-86	4WD	N/A	N/A		■	23000*/ 4169 80199-81099	23000*/ 4169	50/ 123 78
CJ	45-71	4WD	N/A	N/A		■	23000*/ 4169	23000*/ 4169	50/ 123
Comanche	85-92	RWD/4WD	N/A	N/A			23510-23540/ 23580, 72509 47240-47242	23510-23540/ 23580, 72509	53,53 123,129 59
Commander (XK)	06-10	RWD/4WD	N/A	N/A			OEMA	OEMA 23410/ 72509	53/ 129
Compass (MK)	07-13	FWD/AWD	67455	OEMA	66		N/A	81260	79
Grand Cherokee (WK2)	11-14	RWD/AWD	OEMA	OEMA			OEMA 82360	OEMA 82360	81,81
Grand Cherokee	05-10	RWD/4WD	N/A	N/A			OEMA	OEMA 23410/ 72509	53/ 129
Grand Cherokee (WJ)	99-04	RWD/4WD	N/A	N/A			23510-23540/ 23580, 72509 47240-47242	23510-23540/ 23580, 72509	53,53 123,129 59
Grand Cherokee (ZJ)	93-98	RWD/4WD	N/A 82370 - Rear Pinion Angle	N/A	81		23510-23540/ 23580, 72509 47240-47242	23510-23540/ 23580, 72509	53,53 123,129 59
Jeepster, Commando	62-73	4WD	N/A	N/A		■	23000*/ 4169	23000*/ 4169	50/ 123
Liberty (JK)	02-12	FWD/AWD	N/A	N/A			OEMA	OEMA	
Patriot (MK)	07-13	FWD/AWD	67455	OEMA	66		N/A	81260	79
Pickup, J10/J20 (SJ)	74-84	4WD	N/A	N/A		■	23000*/ 4169	23000*/ 4169	50/ 123
Scrambler	82-86	4WD	N/A	N/A		■	23000*/ 4169	23000*/ 4169	50/ 123
Wagoneer (XJ)	84-93	RWD/4WD	N/A	N/A		■	23510-23540/ 23580, 72509 47240-47242	23510-23540/ 23580, 72509	53,53 123,129 59
Wagoneer (Grand) (SJ)	74-91	4WD	N/A	N/A		■	23000*/ 4169	23000*/ 4169	50/ 123

ALIGNMENT FOOTNOTES BOLD PART NUMBER INDICATES PREFERRED CORRECTION METHOD

- (1) = CAUTION: Check for caliper to rotor clearance with disc brakes. Use spacer set 75970 (pg. 78) as necessary to keep caliper centered on rotor • (2) = All EXCEPT RWD 1500
 (3) = Honda S2000 Ball Joint - Rear Application - Only for 17" rims or larger • (4) = Check Bolt Length BEFORE Cutting Hole • (5) = Shims (pg. 58)
 (6) = LH Tie Rod Adjusting Sleeve Replacement (pg. 53) • (7) = Bolts, 73415, are necessary for changes greater than 3/4" (pg. 77) • (8) = Recommended for vehicles lowered more than 1.5"
 (9) = Will not work on 1988-89 models with welded-in ball joint • (10) = M3 Only, caster will decrease by 2 degrees • (11) = Pinion Angle Adj. Part No. 82370 (pg. 81)
 (12) = Limited camber range of ±1.0° • (13) = Center stock camber and toe adjusters before calculating shim change • (14) = 69330 included w/69300 or 69400 • (15) = Not for use w/disc brake
 ■ = Thrust Alignment Plate can correct thrust angle and setback (pg. 59) / Check frame angle with Angle Gauge Part No. 64225 (pg. 127)
 N/A = No Available Adjuster • OEMA = Original Equipment Manufacturer Adjustment • (*) = Series P/N, for correct size • SW = Station Wagon

©2013 Niwot Corp. dba Specialty Products Co.®

All products from Specialty Products Company are intended for use by professional installers only.



www.specprod.com

Call for your nearest distributor, product info or
Technical Assistance • In the USA and Canada

1-800-525-6505

Applications
Parts
Heavy Duty
Racing/Off Road
Tools
Accessories
Brake & CV
Gear/Index

Applications

CAR/MINI-VAN/SUV/TRUCK APPLICATIONS

JEEP-cont.

Model/Body Style	Year	Drive Type	REAR CAMBER/TOOL	TOE/TOOL	Page	Thrust Plate	FRONT CASTER/TOOL	CAMBER/TOOL	Page
Wrangler (JK) <i>Jounce/Shock System Avail.-Pg. 120</i>	07-14	RWD/4WD	N/A 82390/ 74910 - Rear	N/A <i>Pinion Angle</i>	81/ 129		23510-23540/ 23580, 72509 82390/ 74910	23510-23540/ 23580, 72509 <i>(Caster & Pinion Angle)</i>	53,53 123,129 81/ 129
Wrangler (TJ)	97-06	4WD	N/A 82370 - Rear	N/A <i>Pinion Angle</i>	81	■	23510-23540/ 23580, 72509 82380 Caster &	23510 - 23540/ 23580, 72509 <i>Pinion Angle)</i>	53,53 123,129 81
Wrangler (YJ)	87-95	4WD	N/A	N/A			23510-23540/ 23580, 72509 Axle Wedges	23510-23540/ 23580, 72509	53,53 123,129

KENWORTH

See our HeavyDuty Section pages 101-110

KIA

Amanti	07-11	FWD	OEMA	OEMA			N/A	67195/ 40920	63/ 125
Amanti	04-06	FWD	N/A	OEMA			N/A	67190/ 40920	63/ 125
Borrego	09-11	FWD/AWD	OEMA	OEMA			OEMA	OEMA	
Cadenza	10-12	FWD	N/A	OEMA			N/A	N/A	
Forte	09-13	FWD	75600(1)	75600(1)	78,78		N/A	81260	79
Optima after 7/1/11	12-13	FWD	OEMA	OEMA			N/A	81280	79
Optima before 7/1/11	11-12	FWD	OEMA	OEMA			N/A	81260	79
Optima	09-10	FWD	N/A	OEMA			N/A	81260	79
Optima	07-08	FWD	67410	OEMA 67410/ 85130	66 66/ 133		N/A	81260	79
Optima	01-06	FWD	N/A	OEMA			N/A	67190/ 40920	63/ 125
Rio/Rio Cinco	12-13	FWD	N/A	N/A			N/A	81260	79
Rio/Rio Cinco	01-11	FWD	75800(1)	75800(1)	78,78		N/A	81250	79
Rondo	07-12	FWD	67410	OEMA 67410/ 85130	66 66/ 133		N/A	81260	79
Sedona	06-12	FWD	N/A	OEMA			N/A	81260	79
Sedona	02-05	FWD	N/A	N/A			N/A	81260	79
Sephia	94-02	FWD	81250	OEMA	79		N/A	OEMA 81250	79
Sorento	11-13	FWD/AWD	OEMA	OEMA			N/A	81260	79
Sorento	03-10	FWD/AWD	N/A	N/A			N/A	81250	79
Soul	09-13	FWD	75600(1)	75600(1)	78,78		N/A	81260	79
Spectra	01-09	FWD	81250	OEMA	79		N/A	81250	79
Sportage	11-13	FWD/AWD	OEMA	OEMA			N/A	81260	79
Sportage	05-10	FWD/AWD	81260	OEMA	79		N/A	81260	79
Sportage	95-03	FWD/AWD	N/A	N/A			OEMA	OEMA	

LAND ROVER

Discovery	99-04	4WD	N/A	N/A			N/A	N/A	
Freelander	02-06	4WD	81260	OEMA	79		N/A	81260	79
LR2	05-13	4WD	N/A	OEMA			N/A	N/A	
LR3	05-09	4WD	N/A	OEMA			OEMA	OEMA	
LR4	10-13	4WD	N/A	OEMA			OEMA	OEMA	
Range Rover Evoque	13-14	4WD	N/A	N/A			N/A	N/A	
Range Rover	03-12	4WD	N/A	OEMA			N/A	81280	79
Range Rover	95-02	4WD	N/A	N/A			N/A	N/A	

LEXUS

CT	11-13	FWD	N/A	OEMA			N/A	81290	79
ES	13-14	FWD	81290	N/A	79		N/A	81290	79
ES	92-12	FWD	81270	OEMA	79		N/A	81290 82120/ 85130	79 81/ 133
ES	90-91	FWD	81270	OEMA	79		85690, 85695	81290 82120/ 85130	84,84,79 81/ 133
GS	13-13	RWD/AWD	N/A	N/A			N/A	N/A	
GS	06-12	RWD/AWD	67520	OEMA	68		N/A	OEMA 67530/ 40920	68/ 125
GS	98-05	RWD	OEMA 67510/ 85130	OEMA	67/ 133		72270	OEMA 72270	76 76
GS	93-97	RWD	OEMA	OEMA			OEMA 72270	OEMA 72270	76,76
GX	10-13	RWD/4WD	N/A	N/A			OEMA 25440/ 40915 25480	OEMA 25440/ 40915 25480	56/ 125 56,56

CAR/MINI-VAN/SUV/TRUCK APPLICATIONS

LEXUS-cont.			REAR			FRONT			
Model/Body Style	Year	Drive Type	CAMBER/TOOL	TOE/TOOL	Page	Thrust Plate	CASTER/TOOL	CAMBER/TOOL	Page
GX <i>Jounce/Shock System Avail.-Pg. 120</i>	03-09	RWD/AWD	N/A	N/A			OEMA 25435/ 40915 25480	OEMA 25435/ 40915 25480	56/ 125 56,56
HS-Hybrid	10-11	FWD	OEMA	OEMA			N/A	81290	79
IS (inc F)	06-13	RWD/AWD	67520	OEMA	68		N/A	67530/ 40920	68/ 125
IS	01-05	RWD	OEMA 67515/ 85130	OEMA	67/ 133		N/A	OEMA 67525/ 40920	68/ 125
LS	07-13	RWD/AWD	N/A	OEMA			OEMA	OEMA	
LS	90-06	RWD/AWD	OEMA	OEMA			OEMA	OEMA	
LX	08-13	AWD	N/A	N/A			OEMA	OEMA	
LX 470	98-07	AWD	N/A	N/A			OEMA	OEMA	
LX 450	96-98	AWD	N/A	N/A			88915, 88920	88915, 88920	89,89
LX 570	08-13	AWD/4WD	N/A	N/A			OEMA 25465/ 40915	OEMA 25465/ 40915	56/ 125
RX	10-13	FWD/AWD	N/A	OEMA			N/A	81290	79
RX	99-09	FWD/AWD	81270	OEMA	79		N/A	81290 82120/ 85130	79 81/ 133
SC	02-10	RWD	OEMA 67510/ 85130	OEMA	67/ 133		72270	OEMA 72270	76 76
SC	92-01	RWD	OEMA	OEMA			OEMA	OEMA	

LINCOLN									
Aviator	03-05	RWD/4WD	86180	OEMA	84		86140	86140	84,84
Blackwood/ EXT	02-03	RWD/4WD	N/A	N/A		■	OEMA 86250	OEMA 86250	84,84
Continental	95-02	FWD	OEMA	OEMA			OEMA	OEMA/ 85790	133
Continental	88-94	FWD	N/A	OEMA			OEMA	OEMA/ 85790	133
Continental	82-87	RWD	N/A	N/A			N/A	OEMA 81280 82120/ 85130	79 81/ 133
LS	00-06	RWD	N/A	OEMA			OEMA 87545	OEMA 87545	89,89
Mark LT	06-09	RWD/4WD	N/A 86255 - Rear Pinion Angle	N/A	84		OEMA 86250	OEMA 86250	84,84
Mark VII	84-92	RWD	N/A	N/A			N/A	OEMA 81280 82120/ 85130	79 81/ 133
Mark VIII	93-97	RWD	OEMA	OEMA			OEMA	OEMA 87535	89
MKS	09-13	FWD/AWD	OEMA	OEMA			N/A	OEMA	
MKT	10-13	FWD/AWD	OEMA	OEMA			N/A	OEMA	
MKX	07-13	FWD/AWD	OEMA	OEMA			N/A	81280	79
MKZ	13-13	FWD/AWD	N/A	N/A			N/A	N/A	
MKZ	07-12	FWD/AWD	OEMA	OEMA			N/A	67115/ 40920	63/ 125
Navigator	07-13	RWD/4WD	OEMA 86255 - Rear Pinion Angle	OEMA	84		OEMA 86250	OEMA 86250	84,84
Navigator	03-06	RWD/4WD	86680	OEMA	86		86640/ 83820	86640/ 83820	86/ 132
Navigator	98-02	RWD/4WD	N/A	N/A			87385	87385	87,87
Town Car	03-11	RWD	N/A	N/A			OEMA	OEMA 87365/ 85130,02099	87/ 133,142
Town Car	91-02	RWD	N/A	N/A			OEMA	OEMA/ 88325	135
Town Car	80-90	RWD	N/A	N/A			OEMA	OEMA	
Zephyr	06-06	FWD/AWD	OEMA	OEMA			N/A	67115/ 40920	63/ 125

MAZDA									
323	90-94	FWD/AWD	81250	OEMA 67070	79 62		N/A	OEMA 81250	79
323	86-89	FWD/AWD	81250	OEMA	79		N/A	OEMA 81250	79
626	83-02	FWD	81250	OEMA	79		OEMA	OEMA 81250	79

ALIGNMENT FOOTNOTES BOLD PART NUMBER INDICATES PREFERRED CORRECTION METHOD

- (1) = CAUTION: Check for caliper to rotor clearance with disc brakes. Use spacer set 75970 (pg. 78) as necessary to keep caliper centered on rotor • (2) = All EXCEPT RWD 1500
 (3) = Honda S2000 Ball Joint - Rear Application - Only for 17" rims or larger • (4) = Check Bolt Length BEFORE Cutting Hole • (5) = Shims (pg. 58)
 (6) = LH Tie Rod Adjusting Sleeve Replacement (pg. 53) • (7) = Bolts, 73415, are necessary for changes greater than 3/4" (pg. 77) • (8) = Recommended for vehicles lowered more than 1.5"
 (9) = Will not work on 1988-89 models with welded-in ball joint • (10) = M3 Only, caster will decrease by 2 degrees • (11) = Pinion Angle Adj. Part No. 82370 (pg. 81)
 (12) = Limited camber range of ±1.0° • (13) = Center stock camber and toe adjusters before calculating shim change • (14) = 69330 included w/69300 or 69400 • (15) = Not for use w/disc brake
 ■ = Thrust Alignment Plate can correct thrust angle and setback (pg. 59) / Check frame angle with Angle Gauge Part No. 64225 (pg. 127)
 N/A = No Available Adjuster • OEMA = Original Equipment Manufacturer Adjustment • (*) = Series P/N, for correct size • SW = Station Wagon

©2013 Niwot Corp. dba Specialty Products Co.®

All products from Specialty Products Company are intended for use by professional installers only.



www.specprod.com

Call for your nearest distributor, product info or
Technical Assistance • In the USA and Canada

1-800-525-6505

Applications
Parts
Heavy Duty
Racing/Off Road
Tools
Accessories
Brake & CV
Gear/Index

Applications

CAR/MINI-VAN/SUV/TRUCK APPLICATIONS

MAZDA-cont.

Model/Body Style	Year	Drive Type	REAR		Page	Thrust Plate	FRONT		Page
			CAMBER/TOOL	TOE/TOOL			CASTER/TOOL	CAMBER/TOOL	
626	79-82	RWD	N/A	N/A			N/A	N/A	
929	92-95	RWD	OEMA	OEMA			N/A	OEMA	
929	88-91	RWD	N/A	OEMA			OEMA	OEMA 81250	79
B-Series Pickup	98-12	RWD/4WD	N/A	N/A		■	87310 87500	87310 87500	87,87 88,88
B-Series Pickup	94-97	RWD/4WD	N/A	N/A		■	23180*/87175 77880, 88830 24180/ 74400, 74500 87280 (RWD Only)	23180*/87175 77880, 88830 24180/ 74400, 74500	52/134 131,135 55,55 129,129 86
CX-5	13-13	FWD/AWD	OEMA	OEMA			N/A	81280	79
CX-7	07-12	FWD/AWD	N/A	OEMA			OEMA	OEMA 81260	79
CX-9	07-13	FWD/AWD	OEMA	OEMA			N/A	81260	79
GLC	82-85	FWD	81250	OEMA	79		N/A	OEMA 81250	79
GLC	77-83	RWD	N/A	N/A			N/A	N/A	
Mazda2	11-13	FWD	N/A	N/A			N/A	81250	79
Mazda3	04-13	FWD	67420	OEMA	66		N/A	N/A	
MazdaSpeed3	04-13	FWD	67420	N/A	66		N/A	N/A	
Mazda5	06-13	FWD	67420	OEMA	66		N/A	N/A	
Mazda6	09-14	FWD/AWD	OEMA	OEMA			N/A	81280	79
Mazda6/MazdaSpeed6	03-08	FWD/AWD	OEMA	OEMA			N/A	67115/40920	63/125
Miata MX-5	90-13	RWD	OEMA	OEMA			OEMA	OEMA	
Millenia	95-02	FWD	OEMA	OEMA			N/A	OEMA	
MPV	89-07	FWD/AWD	N/A	N/A			OEMA	OEMA 81250	79
MX-3	92-95	FWD	81250	OEMA	79		N/A	OEMA 81250	79
MX-6	88-97	FWD	81250	OEMA	79		OEMA	OEMA 81250	79
Navajo	91-94	RWD/4WD	N/A	N/A			23180*/87175 77880, 88830 24180/ 74400, 74500 87280 (RWD Only)	23180*/87175 77880, 88830 24180/ 74400, 74500	52/134 131,135 55,55 129,129 86
Pickup	86-93	RWD/4WD	N/A	N/A		■	OEMA(5)	OEMA(5)	
Protege/ Protege 5	95-04	FWD/AWD	81250	OEMA 67070	79 62		OEMA	OEMA 81250	79
Protege/ Protege 5	90-94	FWD/AWD	81250	OEMA	79		OEMA	OEMA 81250	79
RX7	93-96	RWD	OEMA	OEMA			OEMA	OEMA	
RX7	86-92	RWD	N/A	OEMA			OEMA	OEMA 81250	79
RX7	80-85	RWD	N/A	N/A			OEMA	OEMA	
RX8	04-12	RWD	OEMA	OEMA			OEMA	OEMA	
Tribute	09-11	FWD/AWD	67285	OEMA	64		OEMA	OEMA 81250	79
Tribute	01-08	FWD/AWD	67285	OEMA	65		OEMA	OEMA 81250	79

MERCEDES-BENZ

For All Mercedes' Toe Adjustment - check out our Wheel Spreader Tool - #99918 (pg 137) - This tool takes the 'play' out of the front wheels during alignment. Recommended by Mercedes when aligning all of their vehicles.

B-Class W246	12-13	FWD	N/A	N/A			N/A	N/A	
B-Class W245	05-11	FWD	N/A	N/A			N/A	N/A	
C-Class W204	08-13	RWD/AWD	N/A	OEMA			OEMA	81260	79
C-Class W203	01-07	RWD/AWD	28840/72509,75990	OEMA	57/129,131		N/A	N/A	
C-Class W202	94-00	RWD/AWD	28840/72509,75990	OEMA	57/129,131		OEMA	OEMA	
C-Class W201	82-93	RWD/AWD	N/A	OEMA			OEMA	OEMA	
CL-Class C216	07-13	RWD	N/A	OEMA			N/A	N/A	
CL-Class C214	00-06	RWD	N/A	OEMA			OEMA	OEMA	
CL-Class C215	00-06	RWD	N/A	OEMA			N/A	N/A	
CLK-Class W209	10-12	RWD	OEMA	OEMA			N/A	N/A	
CLK-Class W209 - incl. Cabrio w/o Black Series	03-09	RWD	28840/72509,75990	OEMA	57/129,131		N/A	N/A	

CAR/MINI-VAN/SUV/TRUCK APPLICATIONS

MERCEDDES-cont.			REAR			Thrust Plate	FRONT		Page
Model/Body Style	Year	Drive Type	CAMBER/TOOL	TOE/TOOL	Page		CASTER/TOOL	CAMBER/TOOL	
CLK-Class W208 - incl. Cabrio w/o Black Series	94-03	RWD	28840/72509,75990	OEMA	57/129,131		OEMA	OEMA	
CLS-Class W219	06-11	RWD	N/A	OEMA			OEMA	OEMA	
E-Class W212	10-13	RWD/AWD	N/A	OEMA			N/A	81270	79
E-Class W211	03-09	RWD/AWD	N/A	OEMA			N/A	N/A	
E-Class W210	96-02	RWD/AWD	28840/72509,75990	OEMA	57/129,131		OEMA	OEMA	
E-Class W210-Wagon	96-02	RWD/AWD	N/A	OEMA			OEMA	OEMA	
E-Class W124	86-95	RWD/AWD	28840/72509,75990	OEMA	57/129,131		OEMA	OEMA	
G-Class W461	02-13	AWD	N/A	OEMA			N/A	N/A	
GL-Class X166	12-13	AWD	N/A	N/A			N/A	N/A	
GL-Class X164	06-12	AWD	N/A	N/A			N/A	N/A	
M-Class W166	13-13	AWD	N/A	N/A			N/A	N/A	
M-Class W164	98-12	AWD	N/A	N/A			N/A	N/A	
R-Class W251	06-12	RWD/AWD	OEMA	OEMA			N/A	OEMA	
S-Class W221	99-12	RWD	N/A	OEMA			N/A	N/A	
SL-Class W129	99-02	RWD	28840/72509,75990	OEMA	57/129,131		OEMA	OEMA	
SL-Class R231	12-13	RWD	N/A	N/A			N/A	N/A	
SL-Class R231 AMG	12-13	RWD	N/A	N/A			N/A	N/A	
SL-Class R230	03-12	RWD	N/A	OEMA			OEMA	OEMA	
SL-Class	89-98	RWD	N/A	OEMA			OEMA	OEMA	
SLK R172	12-13	RWD	N/A	N/A			N/A	N/A	
SLK R171	06-11	RWD	28840/72509,75990	OEMA	57/129,131		N/A	N/A	
SLK R170	98-05	RWD	28840/72509,75990	OEMA	57/129,131		OEMA	OEMA	
Sprinter Van Canada	07-13	RWD	N/A	N/A			N/A	35077	57
Sprinter Van Canada	01-06	RWD	N/A	N/A			N/A	35075, 35076	57,57

MERCURY									
Capri	91-94	RWD	81250	OEMA	79		OEMA	OEMA 81250	79
Capri	79-86	RWD	N/A	N/A			N/A	OEMA 81280 82120/85130	79 81/133
Comet	69-77	RWD	N/A	N/A			OEMA	OEMA 83160	79
Comet	60-65	RWD	N/A	N/A			OEMA(5)	OEMA(5)	
Cougar	99-02	FWD	N/A	OEMA			89675	89675	90,90
Cougar	89-97	RWD	OEMA	OEMA			OEMA	OEMA 87535	89
Cougar	80-88	RWD	N/A	N/A			N/A	OEMA 81280 82120/85130	79 81/133
Cougar	67-79	RWD	N/A	N/A			OEMA	OEMA 83160	79
Grand Marquis & SW	03-11	RWD	N/A	N/A			OEMA	OEMA 87365/85130, 02099	87/133,142
Grand Marquis & SW	91-02	RWD	N/A	N/A			OEMA	OEMA/88325	135
Grand Marquis & SW	83-90	RWD	N/A	N/A			OEMA	OEMA	
LN-7	82-85	FWD	81250	OEMA	79		N/A	N/A	
Lynx	81-87	FWD	81250	OEMA	79		N/A	N/A	
Mariner	05-11	FWD/AWD	67285	OEMA	64		OEMA	OEMA 81250	79
Marauder	03-04	RWD	N/A	N/A			OEMA	OEMA 87365/85130, 02099	87/133,142
Marquis	83-86	RWD	N/A	N/A			N/A	OEMA 81280 82120/85130	79 81/133
Milan	06-11	FWD/AWD	OEMA	OEMA			N/A	67115/40920	63/125
Monarch	75-80	RWD	N/A	N/A			OEMA	OEMA 83160	79

ALIGNMENT FOOTNOTES BOLD PART NUMBER INDICATES PREFERRED CORRECTION METHOD

- (1) = CAUTION: Check for caliper to rotor clearance with disc brakes. Use spacer set 75970 (pg. 78) as necessary to keep caliper centered on rotor • (2) = All EXCEPT RWD 1500
 (3) = Honda S2000 Ball Joint - Rear Application - Only for 17" rims or larger • (4) = Check Bolt Length BEFORE Cutting Hole • (5) = Shims (pg. 58)
 (6) = LH Tie Rod Adjusting Sleeve Replacement (pg. 53) • (7) = Bolts, 73415, are necessary for changes greater than 3/4" (pg. 77) • (8) = Recommended for vehicles lowered more than 1.5"
 (9) = Will not work on 1988-89 models with welded-in ball joint • (10) = M3 Only, caster will decrease by 2 degrees • (11) = Pinion Angle Adj. Part No. 82370 (pg. 81)
 (12) = Limited camber range of ±1.0° • (13) = Center stock camber and toe adjusters before calculating shim change • (14) = 69330 included w/69300 or 69400 • (15) = Not for use w/disc brake
 ■ = Thrust Alignment Plate can correct thrust angle and setback (pg. 59) / Check frame angle with Angle Gauge Part No. 64225 (pg. 127)
 N/A = No Available Adjuster • OEMA = Original Equipment Manufacturer Adjustment • (*) = Series P/N, for correct size • SW = Station Wagon

©2013 Niwot Corp. dba Specialty Products Co.®

All products from Specialty Products Company are intended for use by professional installers only.



www.specprod.com

Call for your nearest distributor, product info or
Technical Assistance • In the USA and Canada

1-800-525-6505

Applications
Parts
Heavy Duty
Racing/Off Road
Tools
Accessories
Brake & CV
Gear/Index

Applications

CAR/MINI-VAN/SUV/TRUCK APPLICATIONS

MERCURY-cont.			REAR		Page	Thrust Plate	FRONT		Page
Model/Body Style	Year	Drive Type	CAMBER/TOOL	TOE/TOOL			CASTER/TOOL	CAMBER/TOOL	
Montego	05-07	FWD/AWD	N/A	OEMA			N/A	OEMA	
Montego	66-71	RWD	N/A	N/A			OEMA	OEMA 83160	82
Monterey	04-07	FWD	N/A	N/A			OEMA	OEMA/ 85790 89685	133 90
Mountaineer	06-10	RWD/4WD	OEMA	OEMA			OEMA	OEMA	
Mountaineer	02-05	RWD/4WD	86180	OEMA	84		86140	86140	84,84
Mountaineer	96-01	RWD/4WD	N/A	N/A			87310 87500	87310 87500	87,87 88,88
Mystique	95-00	FWD	N/A	OEMA			89675	89675	90,90
Sable	08-09	FWD/AWD	N/A	OEMA			N/A	OEMA	
Sable Sedan	96-07	FWD	87330/ 8370, 87320	OEMA/ 87325 87330/ 8370, 87320	87/ 123,134 87 123,134		OEMA/ 85790	OEMA/ 85790 89635	133,133 90
Sable Wagon	96-05	FWD	87350/ 85130	OEMA/ 97650	87/ 123,134		OEMA/ 85790	OEMA/ 85790 89635	133,133 90
Sable Sedan	86-95	FWD	87330/ 8370, 87320	OEMA/ 87325 87330/ 8370, 87320	87/ 123,134 87 123,134		OEMA/ 85790	OEMA/ 85790	133,133
Sable Wagon	86-95	FWD	87350/ 85130	OEMA/ 97650	87/ 123,134		OEMA/ 85790	OEMA/ 85790	133,133
Topaz	86-94	FWD/AWD	81250	OEMA/ 87325	79/ 134		N/A	N/A	
Topaz	84-85	FWD/AWD	81250	N/A	79		N/A	N/A	
Tracer	97-99	FWD	81250	N/A	79		N/A	OEMA 81250	79
Tracer	95-96	FWD	81250	OEMA	79		OEMA	OEMA 81250	79
Tracer	91-94	FWD	81250	OEMA 67070	79 62		OEMA	OEMA 81250	79
Tracer	87-90	FWD	81250	OEMA	79		N/A	OEMA 81250	79
Villager	93-02	FWD	75400(1)	75400(1)	78,78		N/A	81250	79
Zephyr	78-83	RWD	N/A	N/A			N/A	OEMA 81280 82120/ 85130	79 81/ 133

MINI COOPER

Cooper/Cooper S/ Conv./Clubman	07-13	FWD	67610	OEMA/ 87560	79/ 134		67630/ 72095	67630/ 72095	69/ 129
Cooper/Cooper S/ Conv.	02-06	FWD	67610	OEMA/ 87560	79/ 134		67620/ 72095	67620/ 72095	69/ 129
Countryman	11-13	FWD/AWD	67610	N/A	79		N/A	N/A	
Coupe	13-13	FWD/AWD	OEMA	OEMA			N/A	OEMA	

MITSUBISHI

3000 GT	90-99	FWD/AWD	OEMA	OEMA			N/A	OEMA 81250	79
Diamante	97-04	FWD	73600 73620(8) 73400+73415(7)	OEMA	77 77 77		N/A	81250	79
Diamante	92-96	FWD/AWD	OEMA	OEMA			N/A	81250	79
Eclipse	06-12	FWD	OEMA	OEMA			N/A	81280	79
Eclipse	00-05	FWD	73600 73620(8) 73400+73415(7)	OEMA	77 77 77		N/A	81280 82120/ 85130	79 81/ 133
Eclipse	95-99	FWD/AWD	73600 73620(8) 73400+73415(7)	OEMA	77 77 77		N/A	67170/40920 67370(8)/ 40920	63/ 125 65/ 125
Eclipse	90-94	FWD	N/A	N/A			N/A	81250	79
Eclipse	90-94	AWD	OEMA	OEMA			N/A	81250	79
Endeavor	04-11	FWD/AWD	OEMA	OEMA			N/A	81280	79
Expo/LRV	92-96	FWD/AWD	N/A	OEMA			N/A	81250	79
Galant	04-12	FWD	OEMA	OEMA			N/A	81280	79
Galant	99-03	FWD/AWD	73600 73620(8) 73400+73415(7)	OEMA	77 77 77		N/A	81280 82120/ 85130	79 81/ 133
Galant	94-98	FWD/AWD	73600 73620(8) 73400+73415(7)	OEMA	77 77 77		N/A	67170/40920 67370(8)/ 40920	63/ 125 65/ 125

CAR/MINI-VAN/SUV/TRUCK APPLICATIONS

MITSUBISHI-cont.			REAR			FRONT			
Model/Body Style	Year	Drive Type	CAMBER/TOOL	TOE/TOOL	Page	Thrust Plate	CASTER/TOOL	CAMBER/TOOL	Page
Galant	85-93	FWD	N/A	N/A			N/A	81250	79
i MiEV	12-13	FWD	N/A	N/A			N/A	N/A	
Lancer	08-13	FWD/AWD	67455	OEMA	66		N/A	81260	79
Lancer Evolution	02-13	AWD	OEMA	OEMA			N/A	81260	79
Lancer/Sportback	02-06	AWD	OEMA	OEMA			N/A	81260	79
Mighty Max/Pickup	87-96	RWD/4WD	N/A	N/A			OEMA(5)	OEMA(5)	
Mirage	94-03	FWD	OEMA	OEMA			N/A	81250	79
Mirage	85-93	FWD/AWD	N/A	N/A			N/A	81250	79
Montero	01-06	FWD/AWD	OEMA	OEMA			OEMA(5)	OEMA(5)	
Montero Sport	97-04	RWD/4WD	N/A	N/A			OEMA	OEMA	
Outlander	07-13	FWD/AWD	67455	OEMA	66		N/A	81260	79
Outlander	03-06	FWD/AWD	N/A	OEMA			N/A	81260	79
Outlander Sport	11-13	FWD/AWD	67455	OEMA	66		N/A	81260	79
Precis	87-93	FWD	N/A	N/A			OEMA	81250	79
Raider	06-09	RWD/4WD	N/A	N/A		■	OEMA/8286	OEMA/8286	123,123
Starion	83-89	RWD	N/A	OEMA			OEMA	N/A	
Tredia	83-88	FWD/AWD	N/A	N/A			OEMA	81250	79
Van/Wagon	87-91	FWD	N/A	N/A			N/A	OEMA	

NAVISTAR

See our HeavyDuty	Section	pages 101-110							
-------------------	---------	---------------	--	--	--	--	--	--	--

NISSAN

200 SX (B14)	94-98	FWD	N/A	N/A			N/A	81250	79
200 SX (S12)	84-88	RWD	N/A	OEMA			N/A	83115/73010(4)	82/129
200 SX (S110)	80-83	RWD	N/A	N/A			N/A	N/A	
240 SX (S14)	95-98	RWD	OEMA 67775, 67776	OEMA 67740	70,70,70		67720	OEMA 81250	70 79
240 SX (S13)	89-94	RWD	OEMA 67765	OEMA 67740	70,70		67720	OEMA 81250	70 79
240 Z	71-73	RWD	N/A	N/A			N/A	83115/73010(4)	82/129
260 Z	74-74	RWD	N/A	N/A			N/A	83115/73010(4)	82/129
280 Z	75-78	RWD	N/A	N/A			N/A	83115/73010(4)	82/129
280 ZX	79-83	RWD	N/A	N/A			N/A	83115/73010(4)	82/129
300 ZX	90-96	RWD	OEMA 67765	OEMA 67765	70,70		N/A	83115/73010(4)	82/129
300 ZX	84-89	RWD	N/A	OEMA			N/A	83115/73010(4)	82/129
350 Z	03-08	RWD	OEMA 72050/85130 72055/85130	OEMA 72050/85130 72055/85130	73/133 73/133		72125/8370	72125/8370	74/123
370 Z	09-13	RWD	OEMA 72260/85130 72265/85130	OEMA 72260/85130 72265/85130	76/133 76/133		72130	72130	75,75
810	77-83	RWD	N/A	N/A			N/A	83115/73010(4)	82/129
Altima	07-13	FWD	OEMA 72290/85130 72055/85130	OEMA 72290/85130 72055/85130	76/133 73/133		N/A	81260	79
Altima	02-06	FWD	OEMA 72050/85130 72055/85130	OEMA 72050/85130 72055/85130	73/133 73/133		N/A	81260	79
Altima	93-01	FWD	81250	OEMA	79		N/A	81250	79
Armada	04-13	RWD/4WD	OEMA	OEMA			87520	87520	88,88
Axxess	90-95	FWD/AWD	N/A	OEMA			N/A	81250	79
B-110	71-73	RWD	N/A	N/A			N/A	N/A	
B-210	74-82	RWD	N/A	N/A			N/A	N/A	
B-310	78-82	RWD	N/A	N/A			N/A	N/A	

ALIGNMENT FOOTNOTES BOLD PART NUMBER INDICATES PREFERRED CORRECTION METHOD

- (1) = CAUTION: Check for caliper to rotor clearance with disc brakes. Use spacer set 75970 (pg. 78) as necessary to keep caliper centered on rotor • (2) = All EXCEPT RWD 1500
 (3) = Honda S2000 Ball Joint - Rear Application - Only for 17" rims or larger • (4) = Check Bolt Length BEFORE Cutting Hole • (5) = Shims (pg. 58)
 (6) = LH Tie Rod Adjusting Sleeve Replacement (pg. 53) • (7) = Bolts, 73415, are necessary for changes greater than 3/4" (pg. 77) • (8) = Recommended for vehicles lowered more than 1.5"
 (9) = Will not work on 1988-89 models with welded-in ball joint • (10) = M3 Only, caster will decrease by 2 degrees • (11) = Pinion Angle Adj. Part No. 82370 (pg. 81)
 (12) = Limited camber range of ±1.0° • (13) = Center stock camber and toe adjusters before calculating shim change • (14) = 69330 included w/69300 or 69400 • (15) = Not for use w/disc brake
 ■ = Thrust Alignment Plate can correct thrust angle and setback (pg. 59) / Check frame angle with Angle Gauge Part No. 64225 (pg. 127)
 N/A = No Available Adjuster • OEMA = Original Equipment Manufacturer Adjustment • (*) = Series P/N, for correct size • SW = Station Wagon

©2013 Niwot Corp. dba Specialty Products Co.®

All products from Specialty Products Company are intended for use by professional installers only.



www.specprod.com

Call for your nearest distributor, product info or
Technical Assistance • In the USA and Canada

1-800-525-6505

Applications

CAR/MINI-VAN/SUV/TRUCK APPLICATIONS

NISSAN-cont.

Model/Body Style	Year	Drive Type	REAR		Page	Thrust Plate	FRONT		Page
			CAMBER/TOOL	TOE/TOOL			CASTER/TOOL	CAMBER/TOOL	
B-510	78-81	RWD	N/A	N/A			N/A	N/A	
Cube	09-13	FWD	75600(1)+73415 75800(1)+73415	75600(1)+73415 75800(1)+73415	78,77 78,77		N/A	81260	79
Frontier <i>JounceShock System Avail.-Pg. 120</i>	05-13	RWD/4WD	N/A	N/A		■	25540 87520	25540 87520	56,56 88,88
Frontier	98-04	RWD/4WD	N/A	N/A		■	OEMA	OEMA	
GT-R	09-13	AWD	OEMA	OEMA			N/A	N/A	
Juke	11-13	FWD/AWD	75600(1)+73415 75800(1)+73415	75600(1)+73415 75800(1)+73415	78,77 78,77		N/A	81260	79
Leaf	11-13	FWD	71020*	71020*	71,71		N/A	81260	79
Maxima	04-13	FWD	OEMA 72050/ 85130 72055/ 85130	OEMA 72050/ 85130 72055/ 85130	73/ 133 73/ 133		N/A	81260	79
Maxima	95-03	FWD	N/A	N/A			N/A	81260	79
Maxima	85-94	FWD	67010	OEMA	60		N/A	81250	79
Maxima	82-84	RWD	N/A	N/A			N/A	83115/ 73010(4)	82/ 129
Murano	03-13	FWD/AWD	OEMA	OEMA			N/A	81260	79
NV	12-13	RWD	N/A	N/A			OEMA	OEMA	
NV200	13-14	FWD	75600(1)+73415 75800(1)+73415	75600(1)+73415 75800(1)+73415	78,77 78,77		N/A	81260	79
NX	91-94	FWD	81250	OEMA	79		N/A	81250	79
Pathfinder	13-14	AWD	N/A	OEMA			N/A	81260	79
Pathfinder <i>JounceShock System Avail.-Pg. 120</i>	05-12	RWD/4WD	OEMA	OEMA			25540 87520	25540 87520	56,56 88,88
Pathfinder	96-04	RWD/4WD	N/A	N/A			N/A	81260	79
Pathfinder	87-95	RWD/4WD	N/A	N/A			35080*	35080*	57,57
Pickup	86-97	RWD/4WD	N/A	N/A		■	35080*	35080*	57,57
Pulsar	87-90	FWD	81250	OEMA	79		N/A	OEMA 81250	79
Pulsar	83-86	FWD	N/A	N/A			N/A	81250	79
Quest	04-13	FWD	OEMA	OEMA			N/A	81260	79
Quest	93-02	FWD	75400(1)	75400(1)	78,78		N/A	81250	79
Rogue	08-13	FWD/AWD	N/A	OEMA			N/A	81260	79
Sentra	13-13	FWD	N/A	N/A			N/A	N/A	
Sentra	07-12	FWD	71730* <i>not for use w/ABS</i>	71720* <i>not for use w/ABS</i>	72,72		N/A	81260	79
Sentra	95-06	FWD	N/A	N/A			N/A	81250	79
Sentra	87-94	FWD	81250	OEMA	79		N/A	OEMA 81250	79
Sentra	83-86	FWD	N/A	N/A			N/A	81250	79
Sentra Wagon	87-90	4WD	81250	OEMA	79		N/A	OEMA 81250	79
Stanza	87-92	FWD	67010	OEMA	60		N/A	81250	79
Stanza	82-86	FWD	N/A	OEMA			N/A	81250	79
Stanza Wagon	85-88	FWD	N/A	N/A			N/A	81250	79
Stanza Wagon	85-88	4WD	81260	OEMA	79		N/A	81250	79
Titan	04-13	RWD/4WD	N/A	N/A		■	87520	87520	88,88
Versa	12-13	FWD	75200(1)	75200(1)	78,78		N/A	81260	79
Versa	07-11	FWD	75600(1)+73415 75800(1)+73415	75600(1)+73415 75800(1)+73415	78,77 78,77		N/A	81260	79
Xterra <i>JounceShock System Avail.-Pg. 120</i>	05-13	RWD/4WD	N/A	N/A		■	25540 87520	25540 87520	56,56 88,88
Xterra	00-04	RWD/4WD	N/A	N/A			OEMA	OEMA	

OLDSMOBILE

442 <i>Pro Springs-Pg. 94</i>	64-72	RWD	N/A	N/A			OEMA(5) 94320 94344 (Lower)	OEMA(5) 94320	92,92 93
88	86-99	FWD	81280 82120/ 85130	OEMA	79 81/ 133		OEMA/ 85130	81280 82120/ 85130	133/79 81/ 133
88 'B' Body <i>Pro Springs-Pg. 94</i>	78-85	RWD	N/A	N/A			OEMA(5) 94378 (Lower)	OEMA(5)	94
88 <i>Pro Springs-Pg. 94</i>	71-77	RWD	N/A	N/A			OEMA(5) 94340 94378 (Lower)	OEMA(5) 94340	92,92 94

CAR/MINI-VAN/SUV/TRUCK APPLICATIONS

OLDSMOBILE-cont.			REAR			FRONT			
Model/Body Style	Year	Drive Type	CAMBER/TOOL	TOE/TOOL	Page	Thrust Plate	CASTER/TOOL	CAMBER/TOOL	Page
98	85-96	FWD	81280 82120/ 85130	OEMA	79 81/ 133		OEMA	81280 82120/ 85130	79 81/ 133
98	77-84	RWD	N/A	N/A			OEMA(5)	OEMA(5)	
Achieva	96-98	FWD	75400(1)	75400(1)	78,78		N/A	81260	79
Achieva	92-95	FWD	75400(1)	75400(1)	78,78		N/A	81280 82120/ 85130	79 81/ 133
Alero	99-04	FWD	81250	OEMA	79		N/A	81260	79
Aurora	95-03	FWD	75600 or 75800(1))	OEMA 75600 or 75800(1)	78,78 78,78		OEMA/ 85130	81280 82120/ 87130	133/79 81/ 133
Bravada	02-04	RWD/AWD	N/A	N/A			OEMA/ 83785	OEMA/ 83785	132,132
Bravada	91-01	AWD	N/A	N/A			OEMA 83710	OEMA 83710	83,83
Cutlass	97-99	FWD	81250	OEMA	79		N/A	81260	79
Cutlass/Supreme	88-97	FWD	81280 82120/ 85130	OEMA/ 83850	79/ 133 81/ 133		N/A	N/A 40930	126
Cutlass Calais	85-91	FWD	75400(1)	75400(1)	78,78		N/A	81280 82120/ 85130	79 81/ 133
Cutlass Ciera	82-96	FWD	75600 or 75800(1)	75600 or 75800(1)	78,78		N/A	82110/ 85130	81/ 133
Custom Cruiser	80-92	RWD	N/A	N/A			OEMA(5)	OEMA(5)	
Cutlass (inc. Supreme) <i>Pro Springs-Pg. 94</i>	78-88	RWD	N/A	N/A			OEMA(5) 94330, 94331 94332(8) 95336 (Lower)	OEMA(5) 94330, 94331 94332(8)	92,92 92,92 95
Cutlass (inc. Supreme) <i>Pro Springs-Pg. 94</i>	73-77	RWD	N/A	N/A			OEMA(5) 94340 94378 (Lower)	OEMA(5) 94340	92,92 94
Cutlass (inc. Supreme) <i>Pro Springs-Pg. 94</i>	64-72	RWD	N/A	N/A			OEMA(5) 94320 94344 (Lower)	OEMA(5) 94320	92,92 93
Firenza	82-89	FWD	75400(1)	75400(1)	78,78		N/A	81280 82120/ 85130	79 81/ 133
Intrigue	97-02	FWD	81260	OEMA/ 83850	79/ 133		N/A	81260	79
LSS	98-99	FWD	81280 82120/ 85130	OEMA	79 81/ 133		OEMA	81280 82120/ 85130	79 81/ 133
Omega	80-84	FWD	75400(1)	75400(1)	78,78		N/A	82110/ 85130	81/ 133
Omega <i>Pro Springs-Pg. 94</i>	75-79	RWD	N/A	N/A			OEMA(5) 94340 94378 (Lower)	OEMA(5) 94340	92,92 94
Regency	97-99	FWD	81280 82120/ 85130	OEMA	79 81/ 133		OEMA	81280 82120/ 85130	79 81/ 133
Silhouette	02-04	AWD	OEMA	OEMA			N/A	81260	79
Silhouette	97-04	FWD	75600 or 75800(1)	75600 or 75800(1)	78,78		N/A	81260	79
Silhouette	90-96	FWD	75600 or 75800(1)	75600 or 75800(1)	78,78		N/A	82110/ 85130	81/ 133
Toronado	86-92	FWD	75600 or 75800(1)	OEMA/ 83775 75600 or 75800(1)	78,78/ 132 78,78		OEMA	OEMA 81280 82120/ 85130	79 81/ 133
Toronado	78-85	FWD	75600 or 75800(1)	OEMA/ 83775 75600 or 75800(1)	78,78 78,78		OEMA	OEMA	
Trofeo	88-92	FWD	75600 or 75800(1)	OEMA 75600 or 75800(1)	78,78 78,78		OEMA	81280 82120/ 85130	79 81/ 133

PETERBILT

<i>See our HeavyDuty</i>	Section	pages 101-110						
--------------------------	---------	---------------	--	--	--	--	--	--

ALIGNMENT FOOTNOTES BOLD PART NUMBER INDICATES PREFERRED CORRECTION METHOD

- (1) = CAUTION: Check for caliper to rotor clearance with disc brakes. Use spacer set 75970 (pg. 78) as necessary to keep caliper centered on rotor • (2) = All EXCEPT RWD 1500
- (3) = Honda S2000 Ball Joint - Rear Application - Only for 17" rims or larger • (4) = Check Bolt Length BEFORE Cutting Hole • (5) = Shims (pg. 58)
- (6) = LH Tie Rod Adjusting Sleeve Replacement (pg. 53) • (7) = Bolts, 73415, are necessary for changes greater than 3/4" (pg. 77) • (8) = Recommended for vehicles lowered more than 1.5"
- (9) = Will not work on 1988-89 models with welded-in ball joint • (10) = M3 Only, caster will decrease by 2 degrees • (11) = Pinion Angle Adj. Part No. 82370 (pg. 81)
- (12) = Limited camber range of ±1.0° • (13) = Center stock camber and toe adjusters before calculating shim change • (14) = 69330 included w/69300 or 69400 • (15) = Not for use w/disc brake
- = Thrust Alignment Plate can correct thrust angle and setback (pg. 59) / Check frame angle with Angle Gauge Part No. 64225 (pg. 127)
- N/A = No Available Adjuster • OEMA = Original Equipment Manufacturer Adjustment • (*) = Series P/N, for correct size • SW = Station Wagon

©2013 Niwot Corp. dba Specialty Products Co.®

All products from Specialty Products Company are intended for use by professional installers only.



www.specprod.com

Call for your nearest distributor, product info or
Technical Assistance • In the USA and Canada

1-800-525-6505

Applications
Parts
Heavy Duty
Facing/On Road
Tools
Accessories
Brake & CV
Gear/Index

Applications

CAR/MINI-VAN/SUV/TRUCK APPLICATIONS

PLYMOUTH			REAR			FRONT			
Model/Body Style	Year	Drive Type	CAMBER/TOOL	TOE/TOOL	Page	Thrust Plate	CASTER/TOOL	CAMBER/TOOL	Page
All Passenger Car Models (Except B & E)	60-73	RWD	N/A	N/A			OEMA 83160	OEMA 83160	82,82
All Passenger B & E Bodies	62-64	RWD	N/A	N/A			OEMA 94450, 94451	OEMA 94450, 94451	95,95
Acclaim	89-95	FWD	75200(1)	75200(1)	78,78		N/A	OEMA 83170/85130	82/133
Barracuda	70-74	RWD	N/A	N/A			OEMA 94450, 94451	OEMA 94450, 94451	95,95
Belvedere	65-70	RWD	N/A	N/A			OEMA 94450, 94451	OEMA 94450, 94451	95,95
Breeze	96-00	FWD	OEMA	OEMA			N/A	67180/40920	63/125
Caravelle	85-88	FWD	75200(1)	75200(1)	78,78		N/A	OEMA 83170/85130	82/133
Colt Vista	85-96	4WD	N/A	OEMA			OEMA	81250	79
Colt Vista	92-94	FWD	N/A	OEMA			N/A	81250	79
Colt Vista	84-91	FWD	N/A	N/A			N/A	81250	79
Conquest	84-86	RWD	N/A	OEMA			OEMA	N/A	
Gran Fury	65-89	RWD	N/A	N/A			OEMA	OEMA	
GTX	67-71	RWD	N/A	N/A			OEMA 94450, 94451	OEMA 94450, 94451	95,95
Horizon	78-90	FWD	75200(1)	75200(1)	78,78		N/A	OEMA 83170/85130	82/133
Laser	92-94	AWD	OEMA	OEMA			N/A	81250	79
Laser	90-94	FWD	N/A	N/A			N/A	81250	79
Neon	95-01	FWD	81250 67210	OEMA 67210	79 63,63		N/A	81260	79
Prowler	97-02	RWD	N/A	N/A			OEMA	OEMA	
Road Runner	68-72	RWD	N/A	N/A			OEMA 94450, 94451	OEMA 94450, 94451	95,95
Reliant	81-89	FWD	75200(1)	75200(1)	78,78		N/A	OEMA 83170/85130	82/133
Sapporo	80-83	RWD	N/A	N/A			N/A	N/A	
Satellite	65-72	RWD	N/A	N/A			OEMA 94450, 94451	OEMA 94450, 94451	95,95
Scamp	82-85	FWD	75200(1)	75200(1)	78,78		N/A	OEMA 83170/85130	82/133
Sundance	87-94	FWD	75200(1)	75200(1)	78,78		N/A	OEMA 83170/85130	82/133
TC3, Turismo	79-87	FWD	75200(1)	75200(1)	78,78		N/A	OEMA 83170/85130	82/133
Trailduster	74-81	4WD	N/A	N/A		■	23000*/4169	23000*/4169	50/123
Trailduster	74-81	RWD	N/A	N/A			OEMA 83160	OEMA 83160	82,82
Valiant	72-76	RWD	N/A	N/A			OEMA 94460, 94461	OEMA 94460, 94461	95,95
Voyager	96-01	AWD	N/A	N/A			N/A	81260 83170/85130	79 82/133
Voyager w/o ABS	96-01	FWD	71730*	71720*	72,72		N/A	81260 83170/85130	79 82/133
Voyager w/ ABS	96-01	FWD	N/A	N/A			N/A	81260 83170/85130	79 82/133
Voyager	90-95	AWD	N/A	N/A			N/A	OEMA 83170/85130	82/133
Voyager	84-95	FWD	75400(1)	75400(1)	78,78		N/A	OEMA 83170/85130	82/133

PONTIAC

1000	81-87	RWD	N/A	N/A			OEMA	OEMA	
2000 Sunbird	82-94	FWD	75400(1)	75400(1)	78,78		N/A	81280 82120/85130	79 81/133
6000/A	82-91	FWD	75600 or 75800(1)	75600 or 75800(1)	78,78		N/A	82110/85130	81/133
Aztec	01-06	AWD	OEMA	OEMA			N/A	81260	79
Aztec	01-06	FWD	75600 or 75800(1)	75600 or 75800(1)	78,78		N/A	81260	79
Bonneville	00-05	FWD	75600 or 75800(1)	OEMA 75600 or 75800(1)	78,78 78,78		N/A	81280 82120/85130	79 81/133
Bonneville	87-99	FWD	81280 82120/85130	OEMA	79 81/133		OEMA/85130	81280 82120/85130	133/79 81/133



CAR/MINI-VAN/SUV/TRUCK APPLICATIONS

PONTIAC-cont.			REAR			FRONT			
Model/Body Style	Year	Drive Type	CAMBER/TOOL	TOE/TOOL	Page	Thrust Plate	CASTER/TOOL	CAMBER/TOOL	Page
Bonneville <i>Pro Springs-Pg. 94</i>	82-86	RWD	N/A	N/A			OEMA(5) 94330, 94331 94332(8) 95336 (Lower)	OEMA(5) 94330, 94331 94332(8)	92,92 92,92 95
Bonneville	77-81	RWD	N/A	N/A			OEMA(5) 94378 (Lower)	OEMA(5)	94
Bonneville <i>Pro Springs-Pg. 94</i>	71-76	RWD	N/A	N/A			OEMA(5) 94340 94378 (Lower)	OEMA(5) 94340	92,92 94
Catalina	65-81	RWD	N/A	N/A			OEMA(5)	OEMA(5)	
Fiero	84-88	RWD	82110/85130	OEMA	81/133		OEMA	OEMA	
Firebird (inc Trans Am)	93-02	RWD	N/A	N/A			OEMA/83775	OEMA/83775	132,132
Firebird (inc Trans Am)	82-92	RWD RWD	N/A	N/A			OEMA	OEMA/8292 81280 82120/85130	123 79 81/133
Firebird 'F'-Body (inc Trans Am) <i>Pro Springs-Pg. 94</i>	70-81	RWD	N/A	N/A			OEMA(5) 94340 94378 (Lower)	OEMA(5) 94340	92,92 94
Firebird 'F'-Body <i>Pro Springs-Pg. 94</i>	67-69	RWD	N/A	N/A			OEMA(5) 94305 94374 (Lower)	OEMA(5) 94305	92,92 94
Firefly	85-91	FWD	N/A	N/A			N/A	81250	79
G3/Wave	05-10	FWD	75200(15)	75200(15)	78,78		N/A	81250	79
G5	05-09	FWD	75400(1)	75400(1)	78,78		N/A	81250	79
G6	05-09	FWD	OEMA 75400(1)(13)	OEMA 75400(1)(13)	78,78		N/A	81250	79
G8	08-09	RWD	OEMA 87430	OEMA 87430	88,88		OEMA	81260	79
Grand Am	04-05	FWD	81250	OEMA	79		N/A	81260	79
Grand Am	99-03	FWD	81250	OEMA	79		N/A	81250	79
Grand Am	96-98	FWD	75400(1)	75400(1)	78,78		N/A	81260	79
Grand Am	88-95	FWD	75400(1)	75400(1)	78,78		N/A	81280 82120/85130	79 81/133
Grand Am <i>Pro Springs-Pg. 94</i>	78-80	RWD	N/A	N/A			OEMA(5) 94330, 94331 94332(8) 95336 (Lower)	OEMA(5) 94330, 94331 94332(8)	92,92 92,92 95
Grand Am <i>Pro Springs-Pg. 94</i>	73-75	RWD	N/A	N/A			OEMA(5) 94340 94378 (Lower)	OEMA(5) 94340	92,92 94
Grand Prix	97-08	FWD	81260	OEMA	79		N/A	81260	79
Grand Prix <i>40930 - Front Strut Set-Page 126</i>	95-96	FWD	81280 82120/85130	OEMA/83850	79/133 81/133		N/A	N/A/85130	133
Grand Prix <i>40930 - Front Strut Set-Page 126</i>	88-94	FWD	81280	OEMA	79		N/A	N/A/85130	133
Grand Prix <i>Pro Springs-Pg. 94</i>	78-87	RWD	N/A	N/A			OEMA(5) 94330, 94331 94332(8) 95336 (Lower)	OEMA(5) 94330, 94331 94332(8)	92,92 92,92 95
Grand Prix <i>Pro Springs-Pg. 94</i>	73-77	RWD	N/A	N/A			OEMA(5) 94340 94378 (Lower)	OEMA(5) 94340	92,92 94
Grand Prix	65-72	RWD	N/A	N/A			OEMA(5)	OEMA(5)	
GTO	04-06	RWD	N/A	OEMA			OEMA	OEMA 81260	79
GTO	64-72	RWD	N/A	N/A			OEMA(5) 94320 94344 (Lower)	OEMA(5) 94320	92,92 93

ALIGNMENT FOOTNOTES BOLD PART NUMBER INDICATES PREFERRED CORRECTION METHOD

- (1) = CAUTION: Check for caliper to rotor clearance with disc brakes. Use spacer set 75970 (pg. 78) as necessary to keep caliper centered on rotor • (2) = All EXCEPT RWD 1500
 (3) = Honda S2000 Ball Joint - Rear Application - Only for 17" rims or larger • (4) = Check Bolt Length BEFORE Cutting Hole • (5) = Shims (pg. 58)
 (6) = LH Tie Rod Adjusting Sleeve Replacement (pg. 53) • (7) = Bolts, 73415, are necessary for changes greater than 3/4" (pg. 77) • (8) = Recommended for vehicles lowered more than 1.5"
 (9) = Will not work on 1988-89 models with welded-in ball joint • (10) = M3 Only, caster will decrease by 2 degrees • (11) = Pinion Angle Adj. Part No. 82370 (pg. 81)
 (12) = Limited camber range of ±1.0° • (13) = Center stock camber and toe adjusters before calculating shim change • (14) = 69330 included w/69300 or 69400 • (15) = Not for use w/disc brake
 ■ = Thrust Alignment Plate can correct thrust angle and setback (pg. 59) / Check frame angle with Angle Gauge Part No. 64225 (pg. 127)
 N/A = No Available Adjuster • OEMA = Original Equipment Manufacturer Adjustment • (*) = Series P/N, for correct size • SW = Station Wagon

©2013 Niwot Corp. dba Specialty Products Co.®

All products from Specialty Products Company are intended for use by professional installers only.



www.specprod.com

Call for your nearest distributor, product info or
Technical Assistance • In the USA and Canada

1-800-525-6505

Applications

Parts

Heavy Duty

Racing/Off Road

Tools

Accessories

Brake & CV

Gear/Index

Applications

CAR/MINI-VAN/SUV/TRUCK APPLICATIONS

PONTIAC-cont.

Model/Body Style	Year	Drive Type	REAR		Page	Thrust Plate	FRONT		Page
			CAMBER/TOOL	TOE/TOOL			CASTER/TOOL	CAMBER/TOOL	
LeMans	88-94	FWD	N/A	N/A			N/A	N/A	
LeMans <i>Pro Springs-Pg. 94</i>	78-81	RWD	N/A	N/A			OEMA(5) 94330, 94331 94332(8) 95336 (Lower)	OEMA(5) 94330, 94331 94332(8)	92,92 92,92 95
LeMans <i>Pro Springs-Pg. 94</i>	73-77	RWD	N/A	N/A			OEMA(5) 94340 94378 (Lower)	OEMA(5) 94340	92,92 94
LeMans	64-72	RWD	N/A	N/A			OEMA(5) 94320 94344 (Lower)	OEMA(5) 94320	92,92 93
Montana/SV6	97-07	FWD	75600 or 75800(1)	75600 or 75800(1)	78,78		N/A	81260	79
Montana/SV6	02-07	AWD	OEMA	OEMA			N/A	81260	79
Phoenix	80-84	FWD	75400(1)	75400(1)	78,78		N/A	82110/85130	81/133
Safari SW	80-89	RWD	N/A	N/A			OEMA(5)	OEMA(5)	
Solstice	06-09	RWD	OEMA	OEMA			OEMA	OEMA	
Sunfire	95-06	FWD	75400(1)	75400(1)	78,78		N/A	81260	79
Tempest	95-06	FWD	75400(1)	75400(1)	78,78		N/A	81260	79
Tempest	64-70	RWD	N/A	N/A			OEMA(5) 94320 94344 (Lower)	OEMA(5) 94320	92,92 93
Torrent	06-09	FWD/AWD	OEMA 87420	OEMA 87420	88,88		N/A	81260	79
Transport	97-99	FWD	75600 or 75800(1)	75600 or 75800(1)	78,78		N/A	81260	79
Transport	90-96	FWD	75600 or 75800(1)	75600 or 75800(1)	78,78		N/A	82110/85130	81/133
Vibe	03-10	AWD	OEMA	OEMA			N/A	81290	79
Vibe	03-10	FWD	75600(1)+73415	75600(1)+73415	78,78		N/A	81290	79

PORSCHE

911	13-13	RWD/AWD	N/A	N/A			N/A	N/A	
911	80-12	RWD/AWD	OEMA	OEMA			N/A	OEMA	
924	80-82	RWD	OEMA	OEMA			OEMA	81250	79
924S	87-88	RWD	OEMA	OEMA			OEMA	81250	79
928	80-96	RWD	OEMA	OEMA			OEMA	OEMA	
944	82-91	RWD	OEMA	OEMA			OEMA	OEMA 81250	79
968	92-95	RWD	OEMA	OEMA			OEMA	OEMA	
Boxster/S	97-13	RWD	OEMA	OEMA			N/A	OEMA	
Cayenne	04-13	AWD	OEMA	OEMA			OEMA	OEMA	
Cayman	06-13	RWD	OEMA	OEMA			N/A	OEMA	
Macan	13-13	FWD/AWD	N/A	N/A			N/A	N/A	
Panamera	10-13	RWD/AWD	OEMA	OEMA			N/A	OEMA	

RAM

See Dodge/Ram Section pages 18-21

SAAB

9-2X	05-07	4WD	81260 67640	OEMA 67640	79 69,69		N/A	81260	79
9-3	08-12	FWD/AWD	OEMA	OEMA			N/A	81250	79
9-3	03-09	FWD	OEMA 75400(1)(13)	OEMA 75400(1)(13)	78,78		N/A	81250	79
9-3	99-02	FWD	N/A	N/A			N/A	N/A	
9-3X	08-12	FWD/AWD	N/A	N/A			N/A	N/A	
9-4X	11-11	FWD/AWD	N/A	N/A			N/A	N/A	
9-5	10-12	FWD/AWD	N/A	N/A			N/A	N/A	
9-5 w/ Auto Leveling Headlights	00-09	FWD	N/A	OEMA			N/A	81250	79
9-5 w/o Auto Leveling Headlights	00-09	FWD	67270	OEMA	64		N/A	81250	79
9-7X	05-09	AWD	N/A	N/A			N/A/83785	OEMA/83785	132,132
99	80-80	FWD	N/A	N/A			OEMA(5)	OEMA(5)	
900	94-99	FWD	N/A	N/A			N/A	N/A	
900	80-93	FWD	N/A	N/A			OEMA(5)	OEMA(5)	
9000	86-98	FWD	N/A	N/A			N/A	81250	79

CAR/MINI-VAN/SUV/TRUCK APPLICATIONS

SATURN			REAR			Page	Thrust Plate	FRONT		Page
Model/Body Style	Year	Drive Type	CAMBER/TOOL	TOE/TOOL	CASTER/TOOL			CAMBER/TOOL		
Astra	08-09	FWD	N/A	N/A			N/A	81250	79	
Aura	07-09	FWD	OEMA 75400(1)(13)	OEMA 75400(1)(13)	78,78		N/A	81250	79	
Ion	03-07	FWD	75400(1)	75400(1)	78,78		N/A	81250	79	
L-Series	00-05	FWD	67270	OEMA	64		N/A	81250	79	
Outlook	07-10	FWD/AWD	OEMA	OEMA			N/A	81280	79	
Relay	05-08	AWD	OEMA	OEMA			N/A	81260	79	
Relay	05-08	FWD	75600 or 75800(1)	75600 or 75800(1)	78,78		N/A	81260	79	
S-Series	91-02	FWD	81260	OEMA 85600/78090	79 83/131		OEMA	81260	79	
Sky	07-09	RWD	OEMA	OEMA			OEMA	OEMA		
Vue	06-09	FWD/AWD	OEMA 87420	OEMA 87420	88,88		N/A	81260	79	
Vue	02-05	FWD/AWD	OEMA	OEMA			N/A	81260	79	
SCION										
FR-S	12-13	RWD	67660/67647,72509	OEMA 67655	70/128,129 70		N/A	81305	80	
iQ	11-13	FWD	75600(1)	75600(1)	78,78		N/A	81250	79	
tC	11-13	FWD	75600(1)	OEMA 75600(1)	78 78		N/A	81290	79	
tC	05-10	FWD	OEMA 67485	OEMA	67		N/A	81290	79	
xA	04-07	FWD	75600(1)	75600(1)	78,78		N/A	81260	79	
xB	08-13	FWD	75600(1)	75600(1)	78,78		N/A	81290	79	
xB	04-07	FWD	75600(1)	75600(1)	78,78		N/A	81260	79	
xD	08-13	FWD	75600(1)	75600(1)	78,78		N/A	81270	79	
SMART										
Fortwo	07-11	RWD	N/A	N/A			N/A	N/A		
SPRINTER										
Sprinter Van	07-13	RWD	N/A	N/A		■	N/A	35077	57	
Sprinter Van	01-06	RWD	N/A	N/A		■	N/A	35075, 35076	57,57	
STERLING										
Bullet	08-11	4WD	N/A	N/A		■	N/A	23850-23854/ 23780, 72509, 88360	54,54 123,129,135	
Bullet	08-11	RWD	N/A	N/A		■	23850-23854/ 23780, 72509, 88360	23850-23854/ 23780, 72509, 88360	54,54 123,129,135 135	
SUBARU										
All (except below)	80-94	AWD	N/A	OEMA			N/A	N/A		
Baja	03-07	AWD	N/A	OEMA			N/A	81260	79	
BRZ	12-13	RWD	67660/67647,72509	OEMA 67655	70/128,129 70		N/A	81305	80	
Forester	09-13	AWD	67660/67647,72509	OEMA 67655	70/128,129 70		N/A	OEMA 81260	79	
Forester	98-08	AWD	81260	OEMA	79		N/A	OEMA 81260	79	
Impreza, WRX, STI	08-13	AWD	67660/67647,72509	OEMA 67655	70/128,129 70		N/A	81260	79	
Impreza, WRX, STI	93-07	AWD	81260 67640 (except STI)	OEMA 67640 (except STI)	79 69,69		N/A	OEMA 81260	79	
Justy	87-94	FWD/AWD	N/A	OEMA			N/A	N/A		
Legacy/Outback/GT	00-13	AWD	N/A	OEMA			N/A	OEMA 81260	79	
Legacy/Outback/GT	90-99	AWD	81260 67640	OEMA 67640	79 69,69		N/A	OEMA 81260	79	
Tribeca	06-13	AWD	N/A	OEMA			N/A	81260	79	
XV Crosstrek	12-13	AWD	N/A	N/A			N/A	81270	79	

ALIGNMENT FOOTNOTES BOLD PART NUMBER INDICATES PREFERRED CORRECTION METHOD

- (1) = CAUTION: Check for caliper to rotor clearance with disc brakes. Use spacer set 75970 (pg. 78) as necessary to keep caliper centered on rotor • (2) = All EXCEPT RWD 1500
 (3) = Honda S2000 Ball Joint - Rear Application - Only for 17" rims or larger • (4) = Check Bolt Length BEFORE Cutting Hole • (5) = Shims (pg. 58)
 (6) = LH Tie Rod Adjusting Sleeve Replacement (pg. 53) • (7) = Bolts, 73415, are necessary for changes greater than 3/4" (pg. 77) • (8) = Recommended for vehicles lowered more than 1.5"
 (9) = Will not work on 1988-89 models with welded-in ball joint • (10) = M3 Only, caster will decrease by 2 degrees • (11) = Pinion Angle Adj. Part No. 82370 (pg. 81)
 (12) = Limited camber range of ±1.0° • (13) = Center stock camber and toe adjusters before calculating shim change • (14) = 69330 included w/69300 or 69400 • (15) = Not for use w/disc brake
 ■ = Thrust Alignment Plate can correct thrust angle and setback (pg. 59) / Check frame angle with Angle Gauge Part No. 64225 (pg. 127)
 N/A = No Available Adjuster • OEMA = Original Equipment Manufacturer Adjustment • (*) = Series P/N, for correct size • SW = Station Wagon

©2013 Niwot Corp. dba Specialty Products Co.®

All products from Specialty Products Company are intended for use by professional installers only.



www.specprod.com

Call for your nearest distributor, product info or
 Technical Assistance • In the USA and Canada

1-800-525-6505

Applications
Parts
Heavy Duty
Tools
Accessories
Gear/Index

Applications

CAR/MINI-VAN/SUV/TRUCK APPLICATIONS

SUZUKI			REAR			Thrust Plate	FRONT		
Model/Body Style	Year	Drive Type	CAMBER/TOOL	TOE/TOOL	Page		CASTER/TOOL	CAMBER/TOOL	Page
Aerio/Aerio SX	03-07	FWD/AWD	81250	OEMA	79	N/A	81250	79	
Equator	09-12	RWD/4WD	N/A	N/A		25540 87520	25540 87520	56,56 88,88	
Esteem	95-02	FWD/AWD	81250	OEMA	79	OEMA	81250	79	
Forenza/Forenza Wgn.	04-08	FWD	81250	OEMA	79	N/A	81250	79	
Forsa/SA310	85-88	FWD	N/A	N/A		N/A	81250	79	
Kizashi	10-12	FWD/AWD	OEMA	OEMA		N/A	N/A		
Reno	05-09	FWD	81250	OEMA	79	N/A	81250	79	
Samurai	86-96	RWD/4WD	N/A	N/A		88905 88906	88905 88906	89,89 89,89	
Side Kick	89-98	RWD/4WD	N/A	N/A		N/A	81250	79	
Swift	89-01	FWD	N/A	OEMA		OEMA	81250	79	
SX4	07-12	FWD/AWD	N/A	N/A		N/A	81250	79	
Verona	04-08	FWD	N/A	OEMA		OEMA	81250	79	
Vitara, Grand Vitara	99-12	FWD/AWD	N/A	N/A		N/A	81250	79	
X-90	97-01	RWD/4WD	N/A	N/A		N/A	81250	79	
XL-7	07-11	FWD/AWD	OEMA 87420	OEMA 87420	88,88	N/A	81260	79	
XL-7	01-06	RWD/4WD	N/A	N/A		N/A	81250	79	

TOYOTA

4-Runner	10-14	RWD/4WD	N/A	N/A		OEMA 25440/40915 25480	OEMA 25440/40915 25480	56/125 56,56
4-Runner <i>JounceShock System Avail.-Pg. 120</i>	03-09	RWD/4WD	N/A	N/A		OEMA 25435/40915 25480	OEMA 25435/40915 25480	56/125 56,56
4-Runner <i>JounceShock System Avail.-Pg. 120</i>	96-02	RWD/4WD	N/A	N/A		OEMA 25430/40915 25460	OEMA 25430/40915 25460	56/125 56,56
4-Runner	84-95	RWD/4WD	N/A	N/A		OEMA	OEMA	
Avalon	13-14	FWD	81290	N/A	79	N/A	81290	79
Avalon	95-12	FWD	81270	OEMA	79	N/A	81290 82120/85130	79 81/133
Camry/Hybrid	12-13	FWD	81270	N/A	79	N/A	81290	79
Camry/Hybrid	92-11	FWD	81270	OEMA	79	N/A	81290 82120/85130	79 81/133
Camry	88-91	FWD/AWD	81270	OEMA	79	85690, 85695	81290 82120/85130	84,84,79 81/133
Camry	83-87	FWD/AWD	81270	OEMA	79	OEMA 85690, 85695	OEMA 81290 82120/85130	84,84,79 81/133
Camry Wagon	88-96	FWD/AWD	81270	OEMA	79	85690, 85695	81290 82120/85130	84,84,79 81/133
Carina	72-73	RWD	N/A	N/A		N/A	N/A	
Celica	00-05	FWD	OEMA 67440	OEMA	66	N/A	81270	79
Celica	86-99	FWD	81270	OEMA	79	N/A	81270	79
Celica Inc Supra	71-85	RWD	N/A	N/A		N/A	N/A	
Celica All-Trac	89-92	AWD	N/A	N/A		N/A	81270	79
Corolla	09-14	FWD	75600(1)	75600(1)	78,78	OEMA	81280	79
Corolla	03-08	FWD	75600(1)+73415	75600(1)+73415	78,77	OEMA	81270	79
Corolla	88-02	FWD	81250	OEMA	79	N/A	81270	79
Corolla All-Trac	89-92	AWD	N/A	N/A		N/A	81270	79
Corolla	84-87	FWD	81250	OEMA	79	N/A	81250	79
Corolla	75-87	RWD	N/A	N/A		OEMA	N/A	
Cressida	89-92	RWD	OEMA	OEMA		OEMA	N/A	
Cressida	85-88	RWD	N/A	OEMA		85690, 85695	N/A	84,84
Cressida	83-84	RWD	N/A	OEMA		OEMA	N/A	
Cressida	82-82	RWD	N/A	N/A		OEMA	N/A	
Cressida	78-81	RWD	N/A	N/A		N/A	N/A	
Cressida Wagon	83-88	RWD	N/A	N/A		OEMA	N/A	
Echo	00-06	FWD	75600(1)	75600(1)	78,78	N/A	81260	79

CAR/MINI-VAN/SUV/TRUCK APPLICATIONS

TOYOTA-cont.			REAR			FRONT			
Model/Body Style	Year	Drive Type	CAMBER/TOOL	TOE/TOOL	Page	Thrust Plate	CASTER/TOOL	CAMBER/TOOL	Page
FJ Cruiser	10-13	RWD/4WD	N/A	N/A			OEMA 25440/ 40915 25480	OEMA 25440/ 40915 25480	56/ 125 56,56
FJ Cruiser <i>JounceShock System Avail.-Pg. 120</i>	07-09	RWD/4WD	N/A	N/A			OEMA 25435/ 40915 25480	OEMA 25435/ 40915 25480	56/ 125 56,56
FX16	86-88	FWD	81250	OEMA	79		N/A	OEMA 81250	79
Highlander	08-13	FWD/AWD	81290	OEMA	79		N/A	81290	79
Highlander	01-07	FWD/AWD	81270	OEMA	79		N/A	81290	79
Landcruiser 200 Series	08-13	AWD/4WD	N/A	N/A			OEMA 25465/ 40915	OEMA 25465/ 40915	56/ 125
Landcruiser 100 Series	98-08	4WD	N/A	N/A			OEMA	OEMA	
Landcruiser 80 Series	90-97	4WD	N/A	N/A		■	88915, 88920	88915, 88920	89,89
Landcruiser 40, 60, 70 Series	65-90	4WD	N/A	N/A		■	88901-88904	88901-88904	89,89
Matrix	03-13	AWD	OEMA	OEMA			N/A	81290	79
Matrix	03-13	FWD	75600 (1) +73415	75600 (1) +73415	78,78		N/A	81290	79
MR 2 Spyder	00-06	RWD	81270	OEMA	79		OEMA	81270	79
MR2	91-97	RWD	81270	OEMA	79		OEMA	81270	79
MR2	85-90	RWD	OEMA 81250	OEMA	79		OEMA	OEMA 81250	79
Paseo	92-97	FWD	N/A	N/A			N/A	81270	79
Pickup	86-94	4WD	N/A	N/A		■	OEMA	OEMA	
Pickup	74-94	RWD	N/A	N/A		■	OEMA (5)	OEMA (5)	
Previa	90-97	RWD/AWD	N/A	N/A			N/A	81290 82120/ 85130	79 81/ 133
Prius	10-13	FWD	75600 (1)	75600 (1)	78,78		N/A	81290	79
Prius	01-09	FWD	75600 (1)	75600 (1)	78,78		N/A	81270	79
Prius C	12-14	FWD	N/A	N/A			N/A	81270	79
Prius Plug-In	12-13	FWD	N/A	N/A			N/A	81290	79
Prius V	12-14	FWD	N/A	N/A			N/A	81290	79
RAV4	06-13	FWD/AWD	N/A	OEMA			N/A	81290	79
RAV4	96-05	FWD/AWD	OEMA	OEMA			N/A	81270	79
Sequoia	08-13	RWD/4WD	OEMA	OEMA			OEMA 25490	OEMA 25490	56,56
Sequoia	01-07	RWD/4WD	N/A	N/A			OEMA 25445/ 40915 25485	OEMA 25445/ 40915 25485	56/ 125 56,56
Sienna	11-13	FWD	N/A	N/A			N/A	81290	79
Sienna	04-13	AWD	N/A	N/A			N/A	81290 82120	79 81
Sienna	98-10	FWD	71020*	71020*	71,71		N/A	81290 82120/ 85130	79 81/ 133
Solara	92-09	FWD	81270	OEMA	79		N/A	81290 82120/ 85130	79 81/ 133
Supra Mark 4	92-02	RWD	OEMA	OEMA			OEMA	OEMA	
Supra Mark 3	86-91	RWD	OEMA	OEMA			OEMA	OEMA	
Supra Celica Mark 2	82-85	RWD	N/A	OEMA			OEMA	N/A	
Supra Celica Mark 1	78-81	RWD	N/A	N/A			OEMA	N/A	
Starlet	81-84	RWD	N/A	N/A			85690, 85695	N/A	84,84
T100	93-98	4WD	N/A	N/A		■	OEMA	OEMA	
T100	93-98	RWD	N/A	N/A		■	OEMA (5)	OEMA (5)	

ALIGNMENT FOOTNOTES BOLD PART NUMBER INDICATES PREFERRED CORRECTION METHOD

- (1) = CAUTION: Check for caliper to rotor clearance with disc brakes. Use spacer set 75970 (pg. 78) as necessary to keep caliper centered on rotor • (2) = All EXCEPT RWD 1500
 (3) = Honda S2000 Ball Joint - Rear Application - Only for 17" rims or larger • (4) = Check Bolt Length BEFORE Cutting Hole • (5) = Shims (pg. 58)
 (6) = LH Tie Rod Adjusting Sleeve Replacement (pg. 53) • (7) = Bolts, 73415, are necessary for changes greater than 3/4" (pg. 77) • (8) = Recommended for vehicles lowered more than 1.5"
 (9) = Will not work on 1988-89 models with welded-in ball joint • (10) = M3 Only, caster will decrease by 2 degrees • (11) = Pinion Angle Adj. Part No. 82370 (pg. 81)
 (12) = Limited camber range of ±1.0° • (13) = Center stock camber and toe adjusters before calculating shim change • (14) = 69330 included w/69300 or 69400 • (15) = Not for use w/disc brake
 ■ = Thrust Alignment Plate can correct thrust angle and setback (pg. 59) / Check frame angle with Angle Gauge Part No. 64225 (pg. 127)
 N/A = No Available Adjuster • OEMA = Original Equipment Manufacturer Adjustment • (*) = Series P/N, for correct size • SW = Station Wagon

©2013 Niwot Corp. dba Specialty Products Co.®

All products from Specialty Products Company are intended for use by professional installers only.



www.specprod.com

Call for your nearest distributor, product info or
Technical Assistance • In the USA and Canada

1-800-525-6505

Applications
Parts
Heavy Duty
Facing/Off Road
Tools
Accessories
Brake & CV
Gear/Index

Applications

CAR/MINI-VAN/SUV/TRUCK APPLICATIONS

TOYOTA-cont.

Model/Body Style	Year	Drive Type	REAR		Page	Thrust Plate	FRONT		Page
			CAMBER/TOOL	TOE/TOOL			CASTER/TOOL	CAMBER/TOOL	
Tacoma <i>JounceShock System Avail.-Pg. 120</i>	05-13	4WD	N/A	N/A		■	OEMA 25435/ 40915 25470	OEMA 25435/ 40915 25470	56/ 125 56,56
Tacoma <i>JounceShock System Avail.-Pg. 120</i>	96-13	RWD	N/A	N/A		■	OEMA	OEMA	
Tacoma <i>JounceShock System Avail.-Pg. 120</i>	95-04	4WD	N/A	N/A			OEMA 25430/ 40915 25460	OEMA 25430/ 40915 25460	56/ 125 56,56
Tacoma Prerunner <i>JounceShock System Avail.-Pg. 120</i>	05-13	RWD	N/A	N/A		■	OEMA 25435/ 40915 25470	OEMA 25435/ 40915 25470	56/ 125 56,56
Tacoma Prerunner <i>JounceShock System Avail.-Pg. 120</i>	98-04	RWD	N/A	N/A			OEMA 25430/ 40915 25460	OEMA 25430/ 40915 25460	56/ 125 56,56
Tercel	87-99	FWD	N/A	N/A			N/A	OEMA 81270	79
Tercel	83-86	FWD/AWD	81250	OEMA	79		85690, 85695	OEMA 81250	84,84 79
Tercel Wagon	87-89	FWD	N/A	OEMA			OEMA	OEMA 81270	79
Tercel Wagon	86-89	4WD	81250	OEMA	79		85690, 85695	OEMA 81270	84,84 79
Tundra	07-13	RWD/4WD	N/A	N/A		■	OEMA 25490	OEMA 25490	84,84 56,56
Tundra	99-06	RWD/4WD	N/A	N/A		■	OEMA 25445/ 40915 25485	OEMA 25445/ 40915 25485	56/ 125 56,56
Van	86-89	RWD/AWD	N/A	N/A			OEMA	OEMA	
Venza	09-13	FWD/AWD	81290	OEMA	79		N/A	81290	79
Yaris	12-13	FWD	N/A	N/A			N/A	81270	79
Yaris	07-11	FWD	75600(1)	75600(1)	78,78		N/A	81270	79

VOLKSWAGEN

Beetle/Conv. w/o Turbo	11-13	FWD	N/A	N/A			N/A	N/A	
Beetle/Conv. w/Turbo	11-13	FWD	OEMA	OEMA			N/A	N/A	
Beetle/Conv.	99-10	FWD	71530*/ 87530	71520*/ 87530	72/ 134		81340	81340	80,80
Cabrio	95-02	FWD	75200(1)+10408	75200(1)+10408	78,49		N/A	81250	79
Cabriolet	85-94	FWD	75200(1)+10408	75200(1)+10408	78,49		N/A	81250	79
CC	06-13	FWD/AWD	OEMA	OEMA			N/A	N/A	
Corrado	90-94	FWD	75200(1)+10408	75200(1)+10408	78,49		N/A	81250	79
Dasher	73-81	FWD	75200(1)+10408	75200(1)+10408	78,49		N/A	OEMA	
Eos (A5)	07-13	FWD	OEMA	OEMA			N/A	N/A	
EuroVan	93-08	FWD/AWD	N/A	OEMA			N/A	OEMA	
Fox	87-94	FWD	75200(1)+10408	75200(1)+10408	78,49		N/A	OEMA	
GLI (A6) w/Multi-Link Rear Suspension	11-13	FWD	OEMA	OEMA			N/A	N/A	
GLI (A5) w/Multi-Link Rear Suspension	05-10	FWD	OEMA	OEMA			N/A	N/A	
Golf (Mk7) w/IRS- Multi Link Rear Suspension	13-13	FWD/AWD	N/A	N/A			N/A	N/A	
Golf (Mk7) w/Beam Type Rear Suspension	13-13	FWD/AWD	N/A	N/A			N/A	N/A	
Golf	10-12	FWD	OEMA	OEMA			N/A	N/A	
Golf R32 (A5)	06-12	FWD	OEMA	OEMA			N/A	N/A	
Golf R32	04-06	FWD	N/A	N/A			81340	81340	80,80
Golf	99-06	FWD	71530*/ 87530	71520*/ 87530	72/ 134		81340	81340	80,80
Golf	84-98	FWD	75200(1)+10408	75200(1)+10408	78,49		N/A	81250	79
GTI R32 (A5)	06-12	FWD	OEMA	OEMA			N/A	N/A	
GTI	99-06	FWD	71530*/ 87530	71520*/ 87530	72/ 134		81340	81340	80,80
GTI	82-98	FWD	75200(1)+10408	75200(1)+10408	78,49		N/A	81250	79
Jetta (A6) w/Beam Rear Axle	11-13	FWD	N/A	N/A			N/A	N/A	
Jetta (A5) w/Multi- Link Rear Suspension	05-12	FWD	OEMA	OEMA			N/A	N/A	
Jetta (A4) w/Beam Type Rear Axle	99-05	FWD	71530*/ 87530	71520*/ 87530	72/ 134		81340	81340	80,80
Jetta	80-98	FWD	75200(1)+10408	75200(1)+10408	78,49		N/A	81250	79

CAR/MINI-VAN/SUV/TRUCK APPLICATIONS

VOLKSWAGEN-cont.			REAR			Page	Thrust Plate	FRONT		Page
Model/Body Style	Year	Drive Type	CAMBER/TOOL	TOE/TOOL	CASTER/TOOL			CAMBER/TOOL		
Passat NMS	12-13	FWD	OEMA	OEMA			N/A	N/A		
Passat (B7)	11-13	FWD	OEMA	OEMA			N/A	N/A		
Passat (B6) w/Multi-Link Rear Suspension	05-10	FWD/AWD	OEMA	OEMA			N/A	N/A		
Passat w/Multi-Link Rear Suspension	01-05	AWD	OEMA	OEMA			N/A	N/A		
Passat w/Beam Type Rear Axle	98-05	FWD	75600(1)+10408 75800(1)+10408	75600(1)+10408 75800(1)+10408	78,49 78,49		81350	81350	80,80	
Passat	90-97	FWD	75200(1)+10408	75200(1)+10408	78,49		N/A	81250	79	
Phaeton	04-06	AWD	OEMA	OEMA			N/A	N/A		
Quantum	82-89	FWD	75200(1)	75200(1)	78,78		N/A	OEMA		
Rabbit	06-09	FWD	OEMA	OEMA			N/A	N/A		
Rabbit	74-84	FWD	75200(1)	75200(1)	78,78		N/A	81250	79	
Routan	09-13	FWD	N/A	N/A			N/A	OEMA 81260 83170/85130	79 82/133	
Scirocco	74-91	FWD	75200(1)	75200(1)	78,78		N/A	OEMA		
Syncro & Vanagon	86-91	RWD/AWD	OEMA	OEMA			OEMA	OEMA		
Tiguan (A5)	09-13	AWD	OEMA	OEMA			N/A	N/A		
Touareg/Touareg2	04-13	AWD	OEMA	OEMA			OEMA	OEMA		
Type I	65-79	RWD	N/A	OEMA			N/A	OEMA		

VOLVO									
90 Series	98-00	RWD	N/A	OEMA			OEMA	81250	79
240	80-91	RWD	N/A	N/A			N/A	OEMA	
740	85-93	RWD	N/A	N/A			OEMA	N/A	
760	83-94	RWD	OEMA	OEMA			OEMA	N/A	
850 GLT	93-97	FWD	N/A	OEMA			N/A	81250	79
940	85-95	RWD	N/A	N/A			OEMA	N/A	
960	95-97	RWD	OEMA	OEMA			N/A	81250	79
C30	08-13	FWD	67420 81310	OEMA	66 80		N/A	N/A	
C70	06-13	FWD	67420	OEMA	66		N/A	N/A	
C70	97-05	FWD	N/A	N/A			N/A	81250	79
GV Series	87-89	RWD	OEMA	OEMA			N/A	81250	79
S40	04-12	FWD/AWD	67420 81310	OEMA	66 80		N/A	N/A	
S40	00-03	FWD	OEMA	OEMA			N/A	81250	79
S60	11-13	RWD/AWD	N/A	OEMA			N/A	N/A	
S60	01-10	RWD/AWD	N/A	OEMA			N/A	81260	79
S70	98-00	FWD/AWD	N/A	OEMA			N/A	81250	79
S80	07-13	RWD/AWD	N/A	N/A			N/A	N/A	
S80	99-06	RWD/AWD	N/A	OEMA			N/A	81260	79
V40	13-13	FWD	N/A	N/A			N/A	N/A	
V40	00-03	FWD	OEMA	OEMA			N/A	81250	79
V50	04-11	FWD/AWD	67420 81310	OEMA	66 80		N/A	N/A	
V70	08-11	FWD/AWD	N/A	OEMA			N/A	N/A	
V70	01-07	FWD/AWD	N/A	OEMA			N/A	81260	79
V70	98-00	FWD/AWD	N/A	OEMA			N/A	81250	79
XC60	09-13	AWD	N/A	OEMA			N/A	N/A	
XC70	08-13	FWD/AWD	N/A	OEMA			N/A	N/A	
XC70	01-07	FWD/AWD	N/A	OEMA			N/A	81260	79
XC90	03-13	AWD	N/A	OEMA			N/A	81260	79

VOLVO & WHITE TRACTORS (OTR)									
See our HeavyDuty	Section	pages 101-110							

ALIGNMENT FOOTNOTES BOLD PART NUMBER INDICATES PREFERRED CORRECTION METHOD

- (1) = CAUTION: Check for caliper to rotor clearance with disc brakes. Use spacer set 75970 (pg. 78) as necessary to keep caliper centered on rotor • (2) = All EXCEPT RWD 1500
- (3) = Honda S2000 Ball Joint - Rear Application - Only for 17" rims or larger • (4) = Check Bolt Length BEFORE Cutting Hole • (5) = Shims (pg. 58)
- (6) = LH Tie Rod Adjusting Sleeve Replacement (pg. 53) • (7) = Bolts, 73415, are necessary for changes greater than 3/4" (pg. 77) • (8) = Recommended for vehicles lowered more than 1.5"
- (9) = Will not work on 1988-89 models with welded-in ball joint • (10) = M3 Only, caster will decrease by 2 degrees • (11) = Pinion Angle Adj. Part No. 82370 (pg. 81)
- (12) = Limited camber range of ±1.0° • (13) = Center stock camber and toe adjusters before calculating shim change • (14) = 69330 included w/69300 or 69400 • (15) = Not for use w/disc brake
- = Thrust Alignment Plate can correct thrust angle and setback (pg. 59) / Check frame angle with Angle Gauge Part No. 64225 (pg. 127)
- N/A = No Available Adjuster • OEMA = Original Equipment Manufacturer Adjustment • (*) = Series P/N, for correct size • SW = Station Wagon

©2013 Niwot Corp. dba Specialty Products Co.®

All products from Specialty Products Company are intended for use by professional installers only.



www.specprod.com

Call for your nearest distributor, product info or Technical Assistance • In the USA and Canada

1-800-525-6505

Applications

Parts

Heavy Duty

Racing/Off Road

Tools

Accessories

Brake & CV

Gear/Index

ESTIMATED INSTALLATION TIMES

(Allow for frozen bolts, nuts, sleeves, etc.) All times are calculated using the recommended special tools.

Part No.	Time/Per Side	Sides Covered Per Kit	Part No.	Time/Per Side	Sides Covered Per Kit	Part No.	Time/Per Side	Sides Covered Per Kit	Part No.	Time/Per Side	Sides Covered Per Kit	Part No.	Time/Per Side	Sides Covered Per Kit
21080	0.3	2	66040	0.6	1	67555	0.3	1	75400	0.5	1	87330	0.5	2
23000	0.5	1	66045	0.6	1	67570	0.5	1	75600	0.5	1	87350	0.5	2
23100	0.5	1	66050	0.6	1	67580	0.5	1	75800	0.5	1	87365	0.8	1
23120	0.5	1	67010	0.8	1	67590	0.5	1	80199	0.5	6	87385	0.4	2
23130	0.5	1	67015	0.5	1	67610	0.6	2	80299	0.5	6	87400	0.4	2
23160	0.5	1	67018	0.5	1	67620	1.2	2	80399	0.5	6	87420	0.3	1
23180	0.5	1	67020	0.8	1	67630	1.2	2	80499	0.5	6	87430	0.6	1
23220	0.5	1	67025	0.5	1	67640	0.8	1	80599	0.5	6	87500	0.5	2
23230	0.5	1	67030	0.5	1	67655	0.5	1	80699	0.5	6	87520	0.4	1
23268	0.5	1	67065	0.5	1	67660	0.5	1	80799	0.5	6	87535	0.2	1
23269	0.5	1	67070	0.5	1	67720	0.3	2	80899	0.5	6	87540	0.4	2
23410	0.6	1	67075	0.6	1	67740	0.3	1	80999	0.5	6	87545	0.4	2
23510	1.0	1	67080	0.5	1	67765	1.0	1	81099	0.5	6	88901	1.4	1
23520	1.0	1	67090	0.5	1	67775	1.0	1	81240	0.4	2	88902	1.4	1
23530	1.0	1	67095	0.5	1	67776	1.0	1	81250	0.4	2	88903	1.4	1
23540	1.0	1	67110	1.3	1	69100	0.3	2	81260	0.4	2	88904	1.4	1
23600	0.5	1	67115	0.6	1	69200	0.3	2	81270	0.4	2	88905	1.4	1
23710	1.0	1	67125	0.6	1	69250	0.6	2	81280	0.4	2	88906	1.4	1
23720	1.0	1	67135	0.6	1	69300	0.3	2	81290	0.4	2	88915	1.4	1
23730	1.0	1	67145	0.6	1	69400	0.3	2	81305	0.4	2	88920	1.4	1
23755	0.3	1	67155	0.6	1	69450	0.6	2	81310	0.5	2	88940	0.4	1
23765	0.3	1	67165	0.6	1	69460	0.6	2	81320	1.2	1	88950	1.4	1
23800	1.0	1	67170	0.6	1	71020	0.5	1	81340	1.2	1	89199	0.5	6
23810	1.0	1	67180	0.6	1	71030	0.5	1	81350	0.7	1	89299	0.5	6
23820	1.0	1	67190	0.6	1	71040	0.5	1	81360	0.7	1	89399	0.5	6
23830	1.0	1	67195	0.6	1	71050	0.5	1	82110	0.4	2	89499	0.5	6
23850	1.0	1	67210	0.4	1	71060	0.5	1	82120	0.6	2	89599	0.5	6
23852	1.0	1	67220	0.6	1	71520	0.5	1	82360	0.5	1	89635	1.0	2
23854	1.0	1	67230	0.5	1	71530	0.5	1	82370	0.3	2	89675	1.2	1
23940	0.6	1	67245	0.6	1	71720	0.5	1	82380	0.4	2	89685	1.2	2
23960	0.6	1	67265	0.5	1	71730	0.5	1	82385	0.4	2	89699	0.5	6
24120	0.5	1	67270	0.8	1	72040	1.0	2	82390	0.4	2	89799	0.5	6
24130	0.5	1	67285	0.8	1	72045	0.5	2	82395	0.4	2	89899	0.5	6
24160	0.5	1	67290	0.5	1	72050	0.6	1	83115	0.8	2	92740	0.7	1
24180	0.5	1	67320	0.6	1	72055	0.6	1	83160	0.4	2	92748	0.7	1
24220	0.5	1	67330	0.6	1	72060	1.0	2	83170	0.4	2	92749	0.7	1
24230	0.5	1	67340	0.6	1	72065	1.2	2	83710	0.5	1	92750	0.7	1
25430	0.3	1	67350	0.6	1	72070	1.2	2	83790	0.5	1	92751	0.7	1
25435	0.3	1	67360	0.6	1	72080	1.2	2	84690	0.5	as req.	92751	0.7	1
25440	0.3	1	67370	0.6	1	72090	1.2	2	84695	0.5	as req.	94305	0.7	1
25445	0.3	1	67395	0.5	1	72110	1.3	2	85600	0.5	2	94320	0.7	1
25460	0.8	2	67410	0.5	1	72125	1.8	2	85690	0.2	as req.	94330	0.7	1
25465	0.8	2	67420	0.5	1	72130	0.6	2	85695	0.2	as req.	94331	0.7	1
25470	0.8	2	67430	0.5	1	72180	1.2	2	86140	0.4	2	94332	0.7	1
25480	0.8	2	67440	0.5	1	72185	0.6	2	86180	0.2	2	94340	0.7	1
25485	0.8	2	67455	0.5	1	72190	1.2	2	86250	0.3	1	94344	1.2	2
25490	0.8	2	67465	0.5	1	72260	0.6	1	86255	0.5	1	94350	0.7	1
25540	1.6	2	67470	0.5	1	72265	0.6	1	86320	0.3	1	94360	0.7	1
25620	0.8	2	67485	0.5	1	72270	0.6	2	86325	0.3	4	94368	0.7	1
28840	0.6	1	67490	0.5	1	72280	0.6	1	86330	0.8	1	94369	0.7	1
35075	0.2	1	67510	0.6	1	72290	0.6	1	86350	0.8	1	94370	0.7	1
35076	0.2	1	67515	0.6	1	72345	0.6	2	86360	0.5	1	94371	0.7	1
35077	0.4	1	67520	0.5	1	72350	1.0	2	86370	0.3	1	94374	1.2	2
47240	0.3	6	67525	0.6	1	72355	0.4	1	86375	0.3	1	94378	1.2	2
47241	0.3	6	67530	0.6	1	73400	0.3	1	86640	0.4	1	94450	0.7	1
47242	0.3	6	67540	0.8	1	73600	0.5	1	86680	0.3	1	94451	0.7	1
62010	0.7	1	67545	0.3	1	73620	0.5	1	87270	0.4	2	94460	0.7	1
63020	0.5	1	67550	0.3	1	75200	0.5	1	87280	0.7	2	94461	0.7	1
63030	0.5	1							87310	0.3	2	95336	1.2	2

MODEL YEAR (V.I.N. Tag Location)

*NOTE: Beginning in 1980 or 1981, all domestic vehicle manufacturers and most import manufacturers refer to the year of vehicle manufacture in the V.I.N. Tag as listed below:

Letter/Number shown in 10th digit of V.I.N. tag.

YEAR DESIGNATION	YEAR DESIGNATION	YEAR DESIGNATION
1981B	1992N	20044
1982C	1993P	20055
1983D	1994R	20066
1984E	1995S	20077
1985F	1996T	20088
1986G	1997V	20099
1987H	1998W	2010A
1988J	1999X	2011B
1989K	2000Y	2012C
1990L	20011	2013D
1991M	20022	2014E
	20033	

CONVERSION TABLE - Toe Readings

Inches	Degrees	Metric MM	Minutes of Degrees
.03 (1/32)	.06° (1/16°)	0.8	3.75'
.06 (1/16)	.13° (1/8°)	1.6	7.50'
.09 (3/32)	.19° (3/16°)	2.4	11.25'
.12 (1/8)	.25° (1/4°)	3.2	15.00'
.16 (5/32)	.31° (5/16°)	4.0	18.75'
.19 (3/16)	.38° (3/8°)	4.8	22.50'
.22 (7/32)	.44° (7/16°)	5.6	26.25'
.25 (1/4)	.50° (1/2°)	6.4	30.00'
.28 (9/32)	.56° (9/16°)	7.1	33.75'
.31 (5/16)	.63° (5/8°)	7.9	37.50'
.34 (11/32)	.69° (11/16°)	8.7	41.25'
.37 (3/8)	.75° (3/4°)	9.5	45.00'
.41 (13/32)	.81° (13/16°)	10.3	48.75'
.44 (7/16)	.88° (5/8°)	11.1	52.50'
.47 (15/32)	.94° (15/16°)	11.9	56.25'
.50 (1/2)	1.00° (1°)	12.7	60.00'
.53 (17/32)	1.06° (1-1/16°)	13.5	1° 3.75'
.56 (9/16)	1.13° (1-1/8°)	14.3	1° 7.50'
.59 (19/32)	1.19° (1-3/16°)	15.1	1° 11.25'
.62 (5/8)	1.25° (1-1/4°)	15.9	1° 15.00'
.66 (21/32)	1.31° (1-5/16°)	16.7	1° 18.75'
.69 (11/16)	1.38° (1-3/8°)	17.5	1° 22.50'
.72 (23/32)	1.44° (1-7/16°)	18.3	1° 26.50'
.75 (3/4)	1.50° (1-1/2°)	19.0	1° 30.00'

Parts

TRUCK SLEEVE BOARD 88210

Containing our most popular truck sleeves, this board set gives you excellent application coverage, while keeping inventory in check.

Shipped with our high-strength polymer display board, hooks and labels.

BOARD INCLUDES ONE EACH OF THE FOLLOWING:

- 23102, 23104, 23106, 23108, 23109, 23112** Change camber and caster on Ford 4WD trucks with twin traction beam Dana 44 and Dana 50 axles.
- 23132, 23134, 23136, 23138, 23139** Change camber and caster on Ford and Dodge trucks including Ford 4WD F350 Crew Cabs and Dodge 4WD BR2500 and RWD & 4WD BR3500 Vans.
- 23182, 23184, 23186, 23188, 23190, 23199** Change camber and caster on twin traction beam Dana 35 suspensions and many other high volume RWD and 4WD Fords.
- 23212, 23222, 23224, 23226, 23228, 23229** Change camber and caster sleeves on 2005 & Up F250 and F350 4WD Ford Super Duty's.
- 24120, 24130, 24180, 24220, 74400, 74500** Adjustable truck sleeves add versatility to this set, along with our special wrenches that make installation easier.



PASSENGER CAR ASSORTMENT BOARD 88260

This Board Set includes our most popular shims and cam kits for passenger vehicles. This is a "must have" for any shop performing 4 wheel alignments on cars, mini vans and SUVs.

Shipped with our high-strength polymer display board, hooks and labels.

BOARD INCLUDES THE FOLLOWING:

- 75200, 75400, 75600** **EZ Shims™** - a patented full contact, dual angle shim set that corrects toe and camber with one shim. These shims cover many rear shimable FWD vehicles on the road today. **#75200, #75400 and #75600 - 2 of each shim included**
- 75915** **EZ Shim™ Cutter** - A necessary tool for properly cutting EZ Shims™. **1 included**
- 75970** **EZ Shim™ Caliper Spacer Set** - Aligns caliper to rotor after installing our EZ Shims™ on some FWD cars with hub mounted rear brakes. **1 set included**
- 10408** **Hub Replacement Bolt Set** - to be used when installing rear shims. **1 set included**
- 81250, 81260, 81270, 81280, 81290** **EZ Cams XR™** - Camber kits for domestic and imported vehicles with two bolt non-slotted struts. Sizes include 12mm, 14mm, 15mm, 16mm and 17mm. **#81260 - 2 kits included, #81250, #81270, #81280 and #81290 - 1 kit included** Each kit contains two cam bolt assemblies, enough for both sides of the vehicle.
- 71720, 71721, 71722, 71723, 71724, 71730, 71731, 71733** **Chrysler and Dodge Mini Van Rear** Camber and Toe Shims. The shim you need to align this very popular platform. **1 of each shim included**
- 72055** **Nissan/Infiniti Rear Camber/Toe Kit.** **1 kit included**
- 87365** **Ford, Mercury, Lincoln Front Camber Adjustment Bolt.** **2 kits included**



LIGHT TRUCK/SUV BOARD 88270

This board set includes the most popular parts for aligning today's trucks and SUVs. Don't be caught without the part that you need. *Shipped with our polymer display board.*

BOARD INCLUDES THE FOLLOWING:

- 21080** **Leaf Spring Silencer™** - Replaces missing or deteriorating OE spring silencer pads. (1)
- 82360** **Jeep/Dodge Cam Kit** - Front Cam/Cas Kit for newer Grand Cherokees & Durangos. (2)
- 82380** **Jeep Pinion Angle Adjusters** - For TJ Series Jeeps, Grand Cherokees & Ram Trucks. (1)
- 86250** **Ford F150 Camber/Caster Cam Bolt Kit** - Front kit for the 2004 & Up F150s. (2)
- 86320** **GM 1/2 & 3/4 Ton Cam Lock Plates** - For 2002 & Up C & K 1500, 2500 and 3500s. (1)
- 86325** **GM 1/2 & 3/4 Ton Alignment Pins** - For 2002 & Up C & K 1500, 2500 and 3500s. (1)
- 86375** **GM Front Alignment Kit** - For 2002 - Up C & K 1500, 2500 & 3500s, Express Vans. (1)
- 86640** **Expedition Front Kit** - For 2002 & Up Expeditions & 2003 & Up Navigators. (2)
- 87385** **Ford F150 Front Camber** - Cam bolt assemblies for 1997 - 03 F150s and F250(LD)s. (1)
- 87400** **GM RWD & 4WD Camber/Caster Kit** - For 1988 - 99 C & K 1500, 2500 and 3500s. (1)
- 87420** **GM Rear Cam Nut** - Cams for 2005 & Up Theta Platforms, including Suzuki XL-7s. (2)
- 87500** **Ford Explorer Front Cam/Cas Kit** - For 1995 - 01 Explorers, 1998 & Up Rangers. (1)
- 87520** **Nissan Camber/Caster Kit** - For 2004 & Up Titan, and 2005 & Up Pathfinder, Xterra. (2)



Also available - our updated Tool Board Set (Part No. 87910) on page 122 - Set up your alignment shop with the tools you need to get going.

BOARD INCLUDES:

- 88120** 23-1/2"x 32" Board w/ hooks
- 75200** EZ Shims™ - Blue (6)
- 75400** EZ Shims™ - Grey (6)
- 75600** EZ Shims™ - Yellow (6)
- 75910** EZ Shim™ Dial Chart (1)
- 75915** EZ Shim™ Cutter (1)
- 75920** EZ Shim™ Marker (1)

EZ SHIM™ BOARD SET 88700

Full coverage of our Blue, Grey and NEW Yellow EZ Shims, plus the tools needed to complete the installation. Hanging board allows for better inventory control.



Parts Get Organized!

BUILD A TOTAL WHEEL ALIGNMENT CUSTOM INVENTORY CONTROL BOARD ANY WAY YOU LIKE IT...

Our complete line of alignment parts may now be displayed in any grouping you would like on a custom inventory control board. The requirements consist of purchasing a minimum of 12 part numbers (excluding SLA shims) of your choice. You select the product, we will package the board, hooks and labels for you to customize your board set. Just copy the form below and mail or fax it to your local distributor, or to Specialty Products for us to forward to your closest distributor. **The board, hooks and labels are *no charge* when 12 different part numbers are purchased.**



DATE _____ PHONE _____ YOUR P.O. NUMBER _____

Bill To:

Ship To:

CUSTOM INVENTORY CONTROL BOARD NO. 88120 - LAYOUT FORM.

Write our part number in the boxes below and the quantity you would like. Each space can hold up to 3 items. Order up to 20 part numbers OR up to 30 truck sleeve part numbers.

Part No. _____ Qty. _____ <i>(Up to three)</i>	Part No. _____ Qty. _____ <i>(Up to three)</i>	Part No. _____ Qty. _____ <i>(Up to three)</i>	Part No. _____ Qty. _____ <i>(Up to three)</i>	Additional Part No. <i>(Truck Sleeves Only)</i> _____ Qty. _____ <i>(Up to three)</i>
Part No. _____ Qty. _____ <i>(Up to three)</i>	Part No. _____ Qty. _____ <i>(Up to three)</i>	Part No. _____ Qty. _____ <i>(Up to three)</i>	Part No. _____ Qty. _____ <i>(Up to three)</i>	Additional Part No. <i>(Truck Sleeves Only)</i> _____ Qty. _____ <i>(Up to three)</i>
Part No. _____ Qty. _____ <i>(Up to three)</i>	Part No. _____ Qty. _____ <i>(Up to three)</i>	Part No. _____ Qty. _____ <i>(Up to three)</i>	Part No. _____ Qty. _____ <i>(Up to three)</i>	Additional Part No. <i>(Truck Sleeves Only)</i> _____ Qty. _____ <i>(Up to three)</i>
Part No. _____ Qty. _____ <i>(Up to three)</i>	Part No. _____ Qty. _____ <i>(Up to three)</i>	Part No. _____ Qty. _____ <i>(Up to three)</i>	Part No. _____ Qty. _____ <i>(Up to three)</i>	Additional Part No. <i>(Truck Sleeves Only)</i> _____ Qty. _____ <i>(Up to three)</i>
Part No. _____ Qty. _____ <i>(Up to three)</i>	Part No. _____ Qty. _____ <i>(Up to three)</i>	Part No. _____ Qty. _____ <i>(Up to three)</i>	Part No. _____ Qty. _____ <i>(Up to three)</i>	Additional Part No. <i>(Truck Sleeves Only)</i> _____ Qty. _____ <i>(Up to three)</i>
Additional Part No. <i>(Truck Sleeves Only)</i> _____ Qty. _____ <i>(Up to three)</i>	Additional Part No. <i>(Truck Sleeves Only)</i> _____ Qty. _____ <i>(Up to three)</i>	Additional Part No. <i>(Truck Sleeves Only)</i> _____ Qty. _____ <i>(Up to three)</i>	Additional Part No. <i>(Truck Sleeves Only)</i> _____ Qty. _____ <i>(Up to three)</i>	Additional Part No. <i>(Truck Sleeves Only)</i> _____ Qty. _____ <i>(Up to three)</i>

Board Dimensions: 23-1/2" x 32". May be hung horizontally or vertically.

IMPORTANT: YOUR PHONE NUMBER, IN CASE WE HAVE QUESTIONS ABOUT YOUR ORDER:

_____ - _____ - _____

HOW TO USE THIS ORDER FORM:

- COPY THIS FORM ON YOUR COPY MACHINE.**
- Choose at least 12 parts from any* listed in our current catalog and get the board, hooks & labels **FREE!** Remember - They need to fit on our Custom Control Board.
- Write the part number and quantity needed in the spaces indicated on the board layout.
- Assign a purchase order number to this order, fill in your company name and address(es), then mail or fax it to your distributor or fax to 1-303-772-1918 and Specialty Products will forward it to your closest distributor.
- Product indicated will be shipped with each Custom Inventory Control Board unless requested differently by customer.

* **Some exclusions do occur, please call for more information.**

M10 X 1.5 X 40 SET OF 8 BOLTS

Contains 8 M10 x 1.5 x 40mm allen head rear hub bolts to be used with the rear shims when needed. Use with EZShims (pg 78).



Installation time: .3 hr/vehicle

Required: 1 per axle

APPLICATIONS

All leaf springs equipped Trucks and SUVs with overload springs - For spring widths from 2-3/4" to 3-1/2"



LEAF SPRING SILENCER™

Replaces Missing or Deteriorating OE Leaf Spring Isolator Pads - set of 4 Silencers

SPC's Leaf Spring Silencer™ is the best aftermarket solution for stopping the 'clunk' when leaf spring equipped trucks go over bumps, railroad tracks and curbs. These rings slide easily over the overload spring and fit spring sizes of 2-3/4" to 3-1/2". Most Ford, Dodge and GM Trucks, plus full-size SUVs have had the factory noise reduction pads fall off or weren't equipped with them, so SPC's Leaf Spring Silencer™ is the perfect solution for millions of vehicles on the road today. Packaged in a set of 4, enough for one truck or SUV.

21080



Perfect for DIY!



Before - the 'stock' isolator pads fall off, allowing the leaf spring to 'bang' over bumps.



After - the Leaf Spring Silencer™ slides easily over the lower leaf spring - creating a silent cushion.

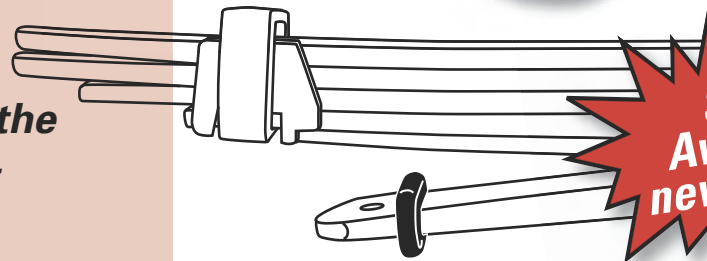

**SEMA
Award for
new product**



Specialty Products exports parts and tools throughout the world, and was awarded a top "Exporter of the Year" award among Colorado companies.

Vehicles that are introduced abroad often end up in the US within a few years. With our export and international partners, SPC is able to develop parts and tools for world platform vehicles before they arrive in the US.



www.specprod.com

Call for your nearest distributor, product info or Technical Assistance • In the USA and Canada

1-800-525-6505

Parts Sleeve Installation Chart

The illustrations below show where to position the slot in the sleeve to get the amount of camber, caster or both needed. Positions 1, 2, 3 & 4 will change camber/caster the amount stamped on the sleeve. Positions 5, 6, 7 & 8 will change the camber/caster by the following amounts:

FOR SLEEVES:
23000 **23100** **23120**
23130 **23180** **23220**
23230

DEGREE	CHANGE	DEGREE	CHANGE	DEGREE	CHANGE	DEGREE	CHANGE
1/4	3/16	3/4	17/32	1-1/4	7/8	1-3/4	1-7/32
1/2	11/32	1	11/16	1-1/2	1-1/16	2	1-13/32

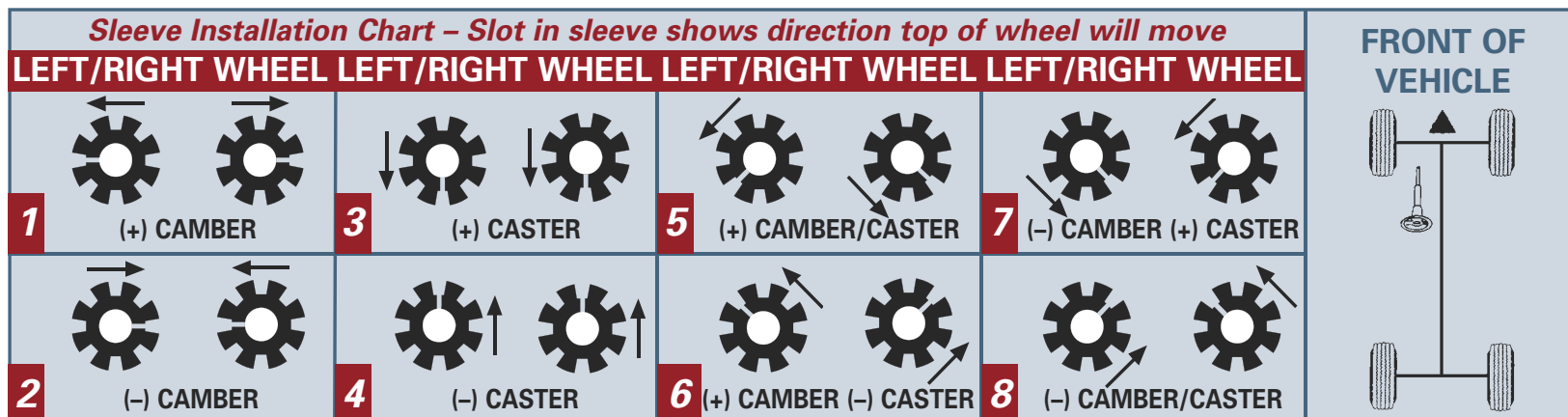

23000 SERIES



4WD BUSHING

This sleeve changes camber and caster on many older model trucks and SUVs with Dana 44 or GMC 10 bolt axles. 4169 spanner socket is required for sleeve removal. Rotate sleeve to fine tune camber/caster adjustment.

Part No.	Total Change
23002	.25° (1/4°)
23004	.50° (1/2°)
23006	.75° (3/4°)
23008	1.00° (1°)
23010	1.25° (1-1/4°)
23012	1.50° (1-1/2°)

Front Adjustment range:
 Camber/Caster $\pm .25^\circ$ to $\pm 1.50^\circ$

Installation time: .5 hr/side Req.: 1 per wheel

APPLICATIONS

Chevrolet/GMC 4WD:

1970 - 87 K10, K15, K20, K25
 1969 - 91 Blazer (K5), Jimmy (K5)
 1969 - 91 Suburban

Dodge 4WD: 1972 - 93 W100, W150, AW150, W200, W250

Ford 4WD: 1966 - 79 F100, F150; 1973 - 79 F250

International 4WD: 1972 - 75 1/2 & 3/4 ton Pickup
 1961 - 71 Scout

Jeep 4WD: 1974 - 83 Cherokee; 1945 - 86 CJ
 1962 - 73 Jeepster, Commando; 1974 - 84 Pickup

1982 - 86 Scrambler; 1974 - 91 Wagoneer/Grand
Plymouth 4WD: 1974 - 81 Trailduster

23100 SERIES



4WD CAM/CAS SLEEVES

Change camber, caster, or both on twin traction beam Dana 44s with these sleeves. Simply remove the tire, cotter pin and upper ball joint stud nut and break the taper free between the stud and sleeve. Using a sleeve puller, remove the existing sleeve. *Install zero degree sleeve 23109 to determine the change needed, then install the correct sleeve.* To split camber and caster adjustment, rotate sleeve 45°.

Set 23100 contains 1 each: 23101, 23102, 23103, 23104, 23105, 23106, 23107, 23108, 23109

Part No.	Total Change	Part No.	Total Change
23101	.25° (1/4°)	23107	1.75° (1-3/4°)
23102	.50° (1/2°)	23108	2.00° (2°)
23103	.75° (3/4°)	23109	0.00° (0°)
23104	1.00° (1°)	23111	2.25° (2-1/4°)
23105	1.25° (1-1/4°)	23112	2.50° (2-1/2°)
23106	1.50° (1-1/2°)	23113	2.75° (2-3/4°)

Front Adjustment range:
 Camber/Caster $\pm .25^\circ$ to $\pm 2.75^\circ$

Installation time: .5 hr/side

Required: 1 per wheel

APPLICATIONS

Ford 4WD:

1980 - 96 Bronco - Full Size
 1980 - 96 F150
 1980 - 98 F250, F350

**Adjustable Sleeve available,
 Part No. 24130 - page 55**

77880 - Puller, pg 131
88830 - Puller, pg 135

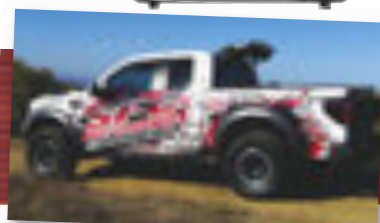

Check out our cutting edge off-road suspension solutions in our Racing Section. SPC features JounceShocks™ (page 118), which will maximize the capacity and performance of many off-road suspensions.

Front Adjustment range:
Camber/Caster $\pm .25^{\circ}$ to $\pm 2.00^{\circ}$
Installation time: .5 hr/side

Required: 1 per wheel

APPLICATIONS

Ford 4WD: (Dana 28)
1983 - 89 Bronco II
1990 Bronco II (Early 90)
1983 - 89 Ranger

Sleeve Installation Chart -
See page 50

Adjustable Sleeve available,
Part No. 24120 - page 55

 **77880 - Puller, pg 131**
88830 - Puller, pg 135

4WD CAM/CAS SLEEVES

Change camber, caster, or both on twin traction beam Dana 28s with these sleeves. Simply remove the tire, cotter pin and upper ball joint stud nut and break the taper free between the stud and sleeve. Using a sleeve puller, remove the existing sleeve. *Install zero degree sleeve 23129 to determine the change needed, then install the correct sleeve.* To split camber and caster adjustment, rotate sleeve 45° .

Set 23120 contains 1 each: 23121, 23122, 23123, 23124, 23125, 23126, 23127, 23128, 23129

Part No.	Total Change	Part No.	Total Change
23121	.25° (1/4°)	23126	1.50° (1-1/2°)
23122	.50° (1/2°)	23127	1.75° (1-3/4°)
23123	.75° (3/4°)	23128	2.00° (2°)
23124	1.00° (1°)	23129	0.00° (0°)
23125	1.25° (1-1/4°)		



23120 SERIES



Front Adjustment range:
Camber/Caster $\pm .25^{\circ}$ to $\pm 2.00^{\circ}$
Installation time: .5 hr/side

Required: 1 per wheel

APPLICATIONS

Dodge RWD:
1994 - 99 3500 Ram w/Mono Beam

Dodge 4WD:
1994 - 99 2500HD, 3500 Ram

Ford RWD/4WD:
1999 - 04 F450, F550

Ford 4WD:
2000 - 05 Excursion
1999 - 04 F250, F350
Solid Axles/Leaf Springs
1992 - 98 F350 Crew Cab

Adjustable Sleeve available,
Part No. 24130 - page 55

4WD & RWD SLEEVES

Change camber, caster, or both at the same time with these sleeves. Simply remove the tire, cotter pin and upper ball joint stud nut and break the taper free between the stud and sleeve. Using a sleeve puller, remove the existing sleeve. *Install zero degree sleeve 23139 to determine the change needed, then install the correct sleeve.* To split camber and caster adjustment, rotate sleeve 45° .

Set 23130 contains 1 each: 23131, 23132, 23133, 23134, 23135, 23136, 23137, 23138, 23139

Part No.	Total Change	Part No.	Total Change
23131	.25° (1/4°)	23136	1.50° (1-1/2°)
23132	.50° (1/2°)	23137	1.75° (1-3/4°)
23133	.75° (3/4°)	23138	2.00° (2°)
23134	1.00° (1°)	23139	0.00° (0°)
23135	1.25° (1-1/4°)		



23130 SERIES



Sleeve Installation Chart -
See page 50

 **77880 - Sleeve Puller, pg 131**
87175 - Sleeve Socket, pg 134
88830 - Sleeve Puller, pg 135

Front Adjustment range:
Camber $\pm .25^{\circ}$ to $\pm 2.00^{\circ}$
Installation time: .5 hr/side

Required: 1 per wheel

APPLICATIONS

Ford RWD:
1984 - 88 Bronco II
1982 - 86 F150
1983 - 88 Ranger

FORD RWD CAMBER SLEEVE

The 23160 series changes camber only from $1/4^{\circ}$ up to 2° Remove the upper ball joint stud nut and break taper free between the stud and sleeve. Calculate change needed and install correct sleeve. Sleeve may be rotated to fine tune camber adjustment.

Set 23160 contains 1 each: 23161, 23162, 23163, 23164, 23165, 23166, 23167, 23168

Part No.	Total Change
23161	.25° (1/4°)
23162	.50° (1/2°)
23163	.75° (3/4°)
23164	1.00° (1°)
23165	1.25° (1-1/4°)
23166	1.50° (1-1/2°)
23167	1.75° (1-3/4°)
23168	2.00° (2°)

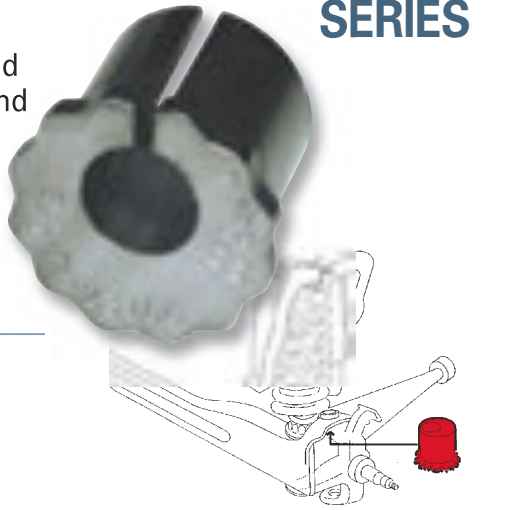

23160 SERIES

Adjustable Sleeve available,
Part No. 24160 - page 55

23160 Sleeve Installation Chart

LEFT/RIGHT WHEEL	LEFT/RIGHT WHEEL	FRONT OF VEHICLE
		
		



Do you specialize in Heavy Duty Trucks or maintain a truck fleet?
Check out our complete Heavy Duty Truck Section on pages 101 - 111.

Parts

23180 SERIES

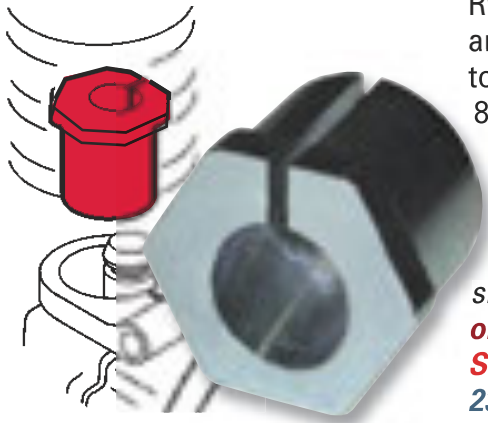

CAMBER/CASTER SLEEVES

These popular sleeves are widely used to adjust caster and/ or camber on many Ford and Mazda RWD & 4WD trucks. To install, simply loosen and remove upper ball joint pinch bolt. Remove top snap ring if one is present. Use 77880 or 88830 sleeve puller to remove the existing sleeve. To split camber and caster adjustment, rotate sleeve 45°. *Save time during alignment, use 23199 zero degree sleeve to determine initial readings, then install correct sleeve. Note: Sleeves adjust to a smaller degree on Ford and Mazda 4WD light trucks/SUVS. Set 23180 contains 1 each: 23181, 23182, 23183, 23184, 23185, 23186, 23187, 23188, 23199*

Series Part No.	RWD Adjustments Total change	4WD Adjustments Total change	Series Part No.	RWD Adjustments Total change	4WD Adjustments Total change
23181	.25° (1/4°)	.20°	23188	2.00° (2°)	1.40°
23182	.50° (1/2°)	.40°	23189	2.25° (2-1/4°)	1.60°
23183	.75° (3/4°)	.60°	23190	2.50° (2-1/2°)	1.80°
23184	1.00° (1°)	.75°	23191	2.75° (2-3/4°)	2.00°
23185	1.25° (1-1/4°)	.90°	23192	3.00° (3°)	2.25°
23186	1.50° (1-1/2°)	1.10°	23193	3.25° (3-1/4°)	2.50°
23187	1.75° (1-3/4°)	1.25°	23194	3.50° (3-1/2°)	2.75°
			23199	0.00° (0°)	

Front Adjustment range:
Camber/Caster $\pm 0.25^\circ$ to $\pm 3.50^\circ$
Installation time: .5 hr/side
Required: 1 per wheel

APPLICATIONS

Ford RWD:

1990 - 90 Bronco II (Late 90-Dana 35)
1992 & Up E150, E250, E350, E450
2000 - 05 Excursion; 1987 - 96 F150
1998 - 13 F250, F350 Twin I-Beam
1987 - 98 F250, F350

Ford RWD/4WD:

1991 - 94 Explorer; 1990 - 97 Ranger

Mazda RWD/4WD:

1994 - 97 B-Series Pickup
1991 - 94 Navajo

Adjustable Sleeve available, Part No. 24180 - page 55

Sleeve Installation Chart - See page 50

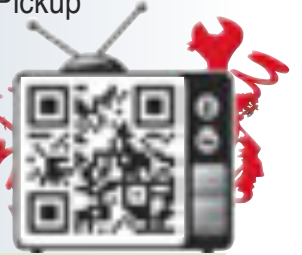

-  77880 - Puller, pg 131
- 87175 - Socket, pg 134
- 88830 - Puller, pg 135

23220 SERIES

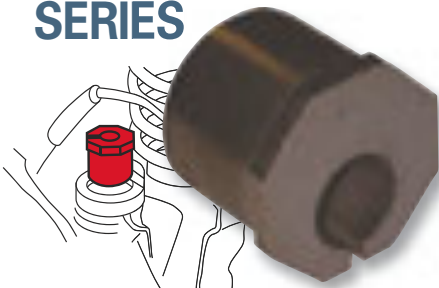

Adjustable Sleeve available, Part No. 24220 - page 55

FORD F250, F350 SLEEVES

Ford changed the axle design in 2005 on their Heavy Duty trucks. These sleeves correct camber and caster on these F250 and F350 Super Duty trucks. *Use the 23229 zero degree sleeve to determine the amount of change needed.*

Part No.	Total Change	Part No.	Total Change
23221	.25° (1/4°)	23227	1.75° (1-3/4°)
23222	.50° (1/2°)	23228	2.00° (2°)
23223	.75° (3/4°)	23229	0.00° (0°)
23224	1.00° (1°)	23211	2.25° (2-1/4°)
23225	1.25° (1-1/4°)	23212	2.50° (2-1/2°)
23226	1.50° (1-1/2°)	<i>Sleeve Install. Chart - pg 50</i>	

Front Adjustment range:
Camber/Caster $\pm 0.25^\circ$ to $\pm 2.50^\circ$
Installation time: .5 hr/side
Required: 1 per wheel

APPLICATIONS

Ford RWD/4WD:

2005 & Up F250, F350
Solid Axle,
Coil Spring



23230 SERIES



Adjustable Sleeve available, Part No. 24230 - page 55

1-1/2 & 2 TON SLEEVES

These truck sleeves will correct alignment problems F450 and F550 Super Duty Trucks with Dana Super 60 solid axles. To split camber and caster adjustment, rotate sleeve 45°. *Use the 23239 zero degree sleeve to determine the amount of change needed.*

Part No.	Total Change	Part No.	Total Change
23231	.25° (1/4°)	23236	1.50° (1-1/2°)
23232	.50° (1/2°)	23237	1.75° (1-3/4°)
23233	.75° (3/4°)	23238	2.00° (2°)
23234	1.00° (1°)	23239	0.00° (0°)
23235	1.25° (1-1/4°)	<i>Sleeve Install. Chart - pg 50</i>	

Front Adj. range:
Camber/Caster $\pm 0.25^\circ$ to $\pm 2.00^\circ$
Installation time: .5 hr/side
Required: 1 per wheel

APPLICATIONS

Chevy/GMC 4WD: 2003 - 09
Kodiak K4500, Topkick K5500

Ford RWD/4WD: 2005 & Up
F450, F550 Coil Springs

23268 23269



FIXED CHANGE FORD SUPER DUTY SLEEVES

These sleeves have a fixed positive camber and caster change and are designed specifically to align trucks that have been lifted or to provide more caster change than our 23220 series. For maximum drivability and to compensate for road crown, use a 23268 on the driver's side and a 23269 on the passenger's side.

Front Adjustment range (Fixed):
23268 Camber +.50 Caster +2.3
23269 Camber +.30 Caster +2.6
Installation time: .5 hr/side
Required: 1 per wheel

APPLICATIONS

Ford RWD/4WD: 2005 & Up
F250, F350 Solid Axle, Coil Spring

JEEP ADJ. BALL JOINT

23410

Front Adjustment range:

Camber $\pm 1.5^\circ$

Installation time: .6 hr/side

Required: 1 per wheel

APPLICATIONS

Jeep: 2006 -10 Commander
2005 - 10 Grand Cherokee



72509 - Ball joint press, pg 129

This upper adjustable ball joint restores proper alignment on lifted Grand Cherokees and Commanders. Our new heavy duty design allows for increased articulation over the OEM ball joint, and ensures proper function and adjustability for the life of the vehicle. **Kit may be used on stock height or lowered vehicles by installing the included Jounce Spacers. The spacers must be installed to prevent the ball joint from contacting the inner fender when the suspension is fully compressed.**



23510 Cam/Cas $\pm .50^\circ$ **23520** Cam/Cas $\pm 1.00^\circ$
23530 Cam/Cas $\pm 1.50^\circ$ **23540** Cam/Cas $\pm 2.00^\circ$

Installation time: 1.0 hr/side Req.: 1 per wheel

APPLICATIONS

Dodge 4WD: 1994 - 01 1500 Ram; 1998 - 99 2500 Ram
Jeep RWD/4WD: 1984 - 01 Cherokee
1985 - 92 Comanche; 1993 - 04 Grand Cherokee
1984 - 93 Wagoneer
1987 & Up Wrangler

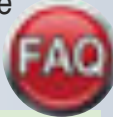

23580 - Ball joint press sleeves, pg 123
72509 - Ball joint press, pg 129

DODGE/JEEP PIN JOINTS

23510 - 23540

Change caster and camber with this upper offset pin joint that replaces the OEM pin joint. Use Installation Sleeve set **23580** in conjunction with **72509** Ball Joint Press for removal and installation of these pin joints.

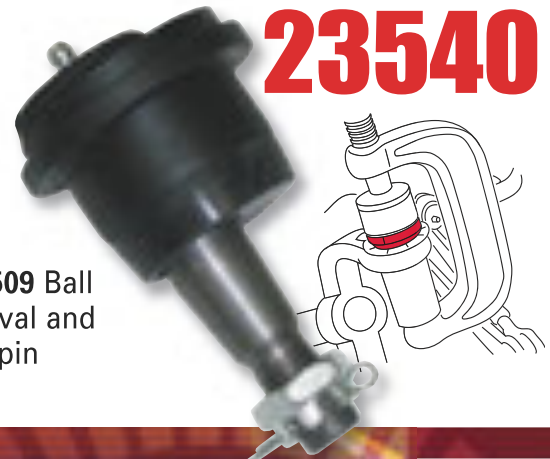

Front Replacement Part

Installation time: .5 hr/side

Required: 1 per wheel

APPLICATIONS

Chrysler: 1999 - 04 300M
1998 - 04 Concorde; 1998 - 01 LHS
Dodge: 1998 - 04 Intrepid

LH REPLACEMENT SLEEVE

23600

This adjustable sleeve replaces the knurled tie rod adjusting sleeve on 1998 - 04 Chrysler LH bodies. Recommended when the existing sleeve has been damaged or if the tie rod end is being replaced so adjustments can be made easily.



55600, 55700 - LH Toe Tools, pg 127

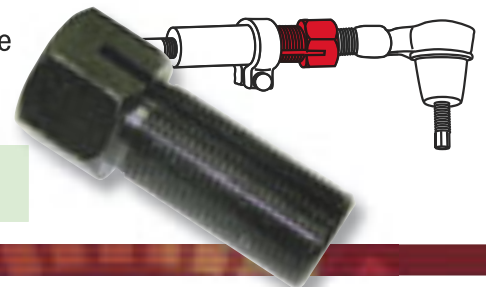

23710 Camber/Caster $\pm .50^\circ$
23720 Camber/Caster $\pm 1.00^\circ$
23730 Camber/Caster $\pm 1.50^\circ$

Installation time: 1.0 hr/side

Required: 1 per wheel

APPLICATIONS

Dodge 4WD: 2000 - 02 2500 Ram,
3500 Ram

DODGE PIN JOINTS

23710 - 23730

These offset pin joints replace the upper pin joint on late model Dodge Trucks. They come in $1/2^\circ$ increments and provide for independent wheel caster and/or camber changes up to $1-1/2^\circ$. Use installation sleeve set **23780** in conjunction with ball joint press **72509** for quick removal and installation of the pin joints.



23780 - Bushing Sleeves, pg 123
72509 - Ball Joint Press, pg 129

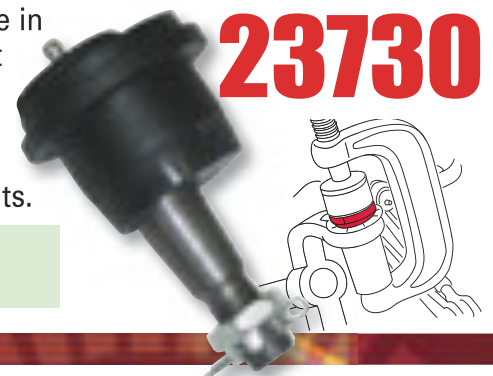

Front Adjustment range:
Camber $\pm 1.00^\circ$ Caster $\pm 1.50^\circ$

Installation time: .3 hr/side

Required: 1 kit per wheel

APPLICATIONS

23755 2 cam/bolt sets
Dodge 4WD: 2002 - 05 1500 Ram

23765 2 cam/bolt sets
Dodge RWD: 2002 - 05 1500 Ram

4WD & RWD DODGE TRUCK CAMBER/CASTER KITS (2)

These heavy duty bolts and brackets replace the upper control arm mounting bolts giving you both camber and caster adjustment. Kit includes 2 cam and bolt sets to cover one side of the vehicle.

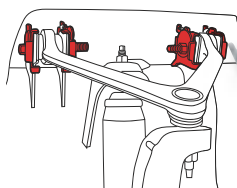

Parts

23800 - 23830

DODGE PIN JOINTS

These offset pin joints replace the upper pin joints on late model Dodge Trucks. They come in 1/2° increments and provide for independent wheel caster and/or camber changes up to 1-1/2°. Use installation sleeve set **23780** in conjunction with ball joint press **72509** for quick removal and installation of the pin joints. ** Note: 23800 is an OEM Replacement*

Ball Joint with no change in camber or caster.

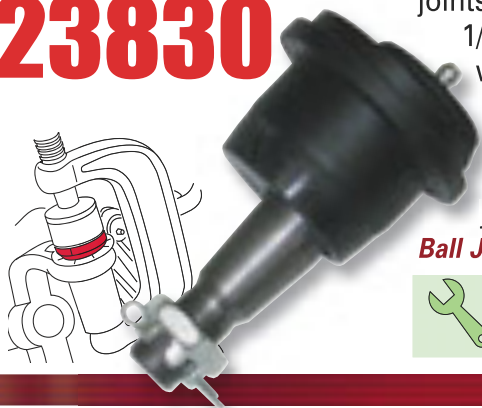

- 23780** - Ball joint press sleeves, pg 123
- 72509** - Ball joint press, pg 129

- 23800*** Camber/Caster 0.0°
- 23810** Camber/Caster ±.50°
- 23820** Camber/Caster ±1.00°
- 23830** Camber/Caster ±1.50°

Installation time: 1.0 hr/side

Required: 1 per wheel

APPLICATIONS

Dodge RWD: 2006 & Up 3500 Ram w/mono beam

Dodge 4WD: 2006 & Up 1500 Ram Mega Cab; 2003 & Up 2500, 3500 Ram

23850 - 23854

DODGE PIN JOINTS

These HND 'King Pin' style joints replace the original sliding-ball design upper joints on late-model 4500 and 5500 Dodge trucks and rebeard Sterling Bullets. They provide independent adjustment up to 1.0° of camber or caster change (camber only on 4WD models due to outboard axle seals) to correct camber or cross-camber issues or to add caster on RWD models for improved tracking.

** Note: 23850 is an OEM Replacement Ball Joint with no change in camber or caster.*

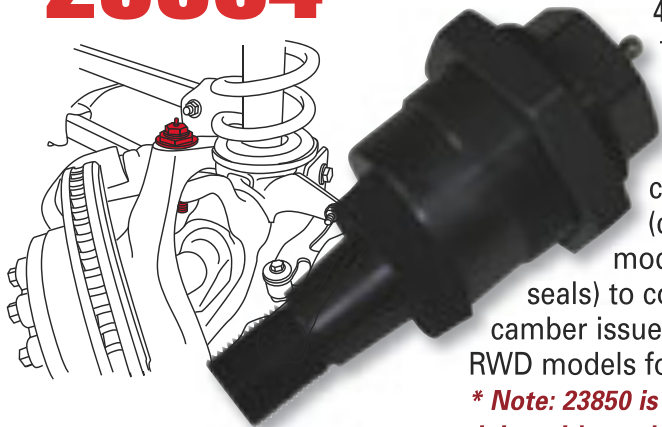

- 23850*** Camber/Caster 0.0°
- 23852** Camber/Caster ±.50°
- 23854** Camber/Caster ±1.00°

Install. time: 1.0 hr/side Req.: 1 per wheel

APPLICATIONS

Dodge RWD/4WD:
(CAMBER CHANGE ONLY ON 4WD)
2008 & Up 4500, 5500

Sterling Bullet RWD/4WD:
(CAMBER CHANGE ONLY ON 4WD)
2008 - 11 4500, 5500

- 23780** - Ball joint press sleeves, pg 123
- 72509** - Ball joint press, pg 129
- 88360** - Adjusting Wrench, pg 135

23940

DODGE 1500 ADJUSTABLE BALL JOINT

Lifted or lowered, factory cams don't give enough adjustment range on the Dodge Ram 1500 series of trucks. Gain 2.25° of camber or caster with these offset ball joints. Simply replace the ball joint in the stock upper control arm to get ±2.25° caster, camber, or a split and then dial in final adjustments with the factory cams. Bring ride quality and tire wear back into the green for your customer.

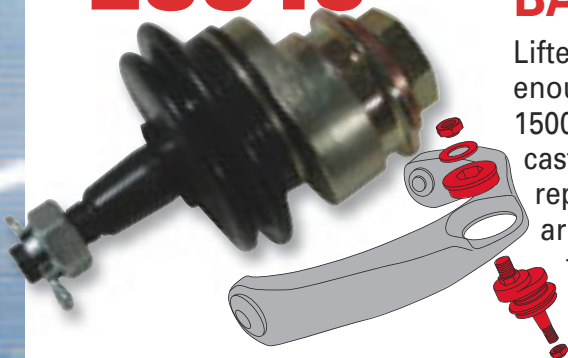

Installation time: .6 hr/side
Req.: 1 per wheel

Camber ±2.25° **OR**
Caster ±2.25°

APPLICATIONS

Dodge/Ram RWD/4WD:
2006 & Up 1500 Ram

- 72509** - Ball Joint Press, pg 129

23960

GM ADJ. BALL JOINT

These heavy duty offset ball joints have a built in 3 degree offset which can be clocked to affect camber, caster, or both. They are ideal for vehicles which cannot be aligned properly with the factory cam bolts due to installation of a lift or leveling kit. As an additional benefit, they also raise the outer end of the upper control arm, which increases clearance between the arm and the droop travel stops on the frame. This restores droop travel on trucks with leveling kits, and eliminates noise vibration harshness caused by arm to frame contact.

Note: Due to strength limitations of the factory upper control arm, this ball joint should not be used on trucks with tires larger than 33" unless a "tall knuckle" lift kit is installed.



Installation time: .6 hr/side
Req.: 1 per wheel

Camber ±3.00°/Caster ±3.00°

APPLICATIONS

Chevy/GMC RWD/4WD:
(With 8 Lug Wheels)
2001 - 06 1500HD Crew Cab
1999 - 10 2500, 3500 Silverado, Sierra
2002 - 06 Avalanche 2500
2000 & Up Suburban 2500
Hummer AWD:
2002 - 09 H2 / H2 SUT

- 72509** - Ball Joint Press, pg 129



Parts Adjustable Sleeves



Inventory getting out of hand? Just need to fill in a few odd sizes? An Adjustable Sleeve may be just what you need. These sleeves can adjust camber and/or caster in a large variety of combinations.
A great solution for saving money and keeping sales.

Replaces up to 5 stock sleeves.

Front Adjustment range: Camber/Caster $\pm 1.00^\circ$ to $\pm 2.75^\circ$
Minimum Adjustment $\pm 1.00^\circ$

Installation time: .5 hr/side Required: 1 per wheel



74500 - Adjustable Sleeve Wrench, pg 129

APPLICATIONS

Ford 4WD: 1983 - 89 Bronco II; 1983 - 89 Ranger
Early 1990 Bronco II (Dana 28)



24120



We have Fixed Sleeves for these Apps, Part No. 23120 - page 51

Replaces up to 24 stock sleeves.

Front Adjustment range: Camber/Caster $\pm .75^\circ$ to $\pm 2.75^\circ$
Minimum Adjustment $\pm .75$

Installation time: .5 hr/side Required: 1 per wheel

APPLICATIONS

Dodge RWD: 1994 - 99 3500 Ram w/Mono Beam
Dodge 4WD: 1994 - 99 2500HD, 3500 Ram
Ford RWD/4WD: 1999 - 04 F450, F550
Ford 4WD: 2000 - 05 Excursion
1999 - 04 F250, F350 Solid Axles/Leaf Springs
1992 - 98 F350 Crew Cab



74500 - Adjustable Sleeve Wrench, pg 129



24130

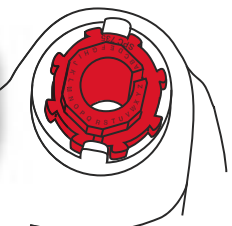

We have Fixed Sleeves for these Apps, Part Nos. 23100 - page 50 and 23130 - page 51

Replaces up to 8 stock sleeves.

Front Adjustment range: Camber 0.0° to $\pm 2.25^\circ$

Installation time: .5 hr/side Required: 1 per wheel



74400 - Adjustable Sleeve Wrench, pg 129

APPLICATIONS

Ford RWD: 1984 - 88 Bronco II; 1982 - 86 F150
1983 - 88 Ranger



24160

We have Fixed Sleeves for these Apps, Part No. 23160 - page 51

Replaces up to 9 stock sleeves.

Front Adjustment range: Camber/Caster $\pm .50^\circ$ to $\pm 2.25^\circ$
Minimum Adjustment $\pm .50^\circ$

Installation time: .5 hr/side Required: 1 per wheel

APPLICATIONS

Ford RWD: 1990 - 90 Bronco II (Late 90-Dana 35)
1992 & Up E150, E250, E350, E450
2000 - 05 Excursion
1987 - 96 F150
1998 - 13 F250, F350 Twin I-Beam
1987 - 98 F250, F350
Ford RWD/4WD: 1991 - 94 Explorer; 1990 - 97 Ranger
Mazda RWD/4WD: 1994 - 97 B-Series Pickup; 1991 - 94 Navajo



74400 - Adj. Sleeve Wrench, pg 129
74500 - Adj. Sleeve Wrench, pg 129

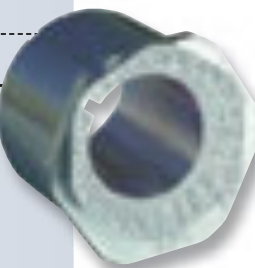

24180

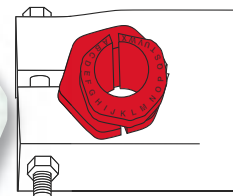

We have Fixed Sleeves for these Apps, Part No. 23180 - page 52

Replaces up to 11 stock sleeves.

Front Adjustment range: Camber/Caster $\pm 2.50^\circ$

Installation time: .5 hr/side Required: 1 per wheel

APPLICATIONS

Ford RWD/4WD: 2005 & Up F250, F350 Solid Axle, Coil Spring

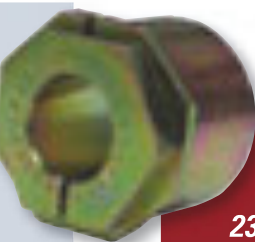

24220

We have Fixed Sleeves for these Apps, Part No. 23220 - page 52

Replaces up to 10 stock sleeves.

Front Adjustment range: Camber/Caster $\pm 2.75^\circ$

Installation time: .5 hr/side Required: 1 per wheel

APPLICATIONS

Chevy/GMC 4WD: 2003 - 09 Kodiak K4500, Topkick K5500
Ford RWD/4WD: 2005 & Up F450, F550 Coil Springs

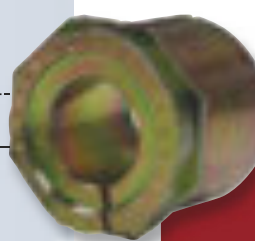

24230

We have Fixed Sleeves for these Apps, Part No. 23230 - page 52



www.specprod.com

Call for your nearest distributor, product info or Technical Assistance • In the USA and Canada

1-800-525-6505

Parts

25430
25435
25440

TOYOTA CAM BOLT KIT

This Cam Bolt Kit is a replacement kit for the OE adjusters. The OE bolts on Toyota trucks and SUV's are frequently "frozen" and do not allow for adjustment. Remove the frozen bolt assembly and replace it with an SPC cam kit to get up to $\pm 1.5^\circ$ camber and caster change.

OE adjuster assemblies that are corroded may require SPC's press tool 40915 for removal, making the job quick and easy.



40915 - Cam Extractor,
pg 125



Front Adjustment range: Cam./Cas. $\pm 1.50^\circ$

Installation time: .3 hr/side Req.: 1 per wheel

25430 APPLICATIONS

Toyota RWD: 1998 - 04 Tacoma PreRunner
Toyota 4WD: 1995 - 04 Tacoma
Toyota RWD/4WD: 1996 - 02 4-Runner

25435 APPLICATIONS

Lexus AWD: 2003 - 09 GX
Toyota RWD: 2005 & Up Tacoma PreRunner
Toyota 4WD: 2005 & Up Tacoma
Toyota RWD/4WD: 2007 - 09 FJ Cruiser
2003 - 09 4Runner

25440 APPLICATIONS

Lexus AWD: 2010 & Up GX
Toyota RWD/4WD: 2010 & Up FJ Cruiser
2010 & Up 4Runner

25445 APPLICATIONS

Toyota RWD/4WD: 2001 - 07 Sequoia
1999 - 06 Tundra

25460
25465
25470
25480
25485
25490

RWD & 4WD TOYOTA FRONT UPPER ARMS (PR)

Many Toyota trucks and SUVs run out of factory adjustment when you install lift kits. With our patented design this upper control arm provides an additional $\pm 2^\circ$ of camber and 0° to $+4^\circ$ of caster change. Built with an OE style ball joint and new **SpecRide™** bushings, this arm is designed to correct alignment angles while maintaining factory ride quality. The hybrid tubular and forged steel design is tough enough to race - on or off-road. These remove and replace arms are available in pairs for lifted and off-road applications.

Patent No. US 7,513,514 B

SpecRide™
Proprietary
Bushings
Feature:

- Free moving pivot sleeve which eliminates failures caused by high travel suspensions
- Vibration and noise control
- Ozone, oil and alkaline resistant material

Front Adjustment range:

Camber $\pm 2.00^\circ$ Caster 0.0° to $+4.00^\circ$

Installation time: .8 hr/side Required: 1 per axle

25460 APPLICATIONS

Toyota RWD: 1998 - 04 Tacoma PreRunner
Toyota 4WD: 1995 - 04 Tacoma
Toyota RWD/4WD: 1996 - 02 4-Runner

25465 APPLICATIONS

Lexus AWD/4WD: 2008 & Up LX 570
Toyota AWD/4WD: 2008 & Up Landcruiser 200

25470 APPLICATIONS

Toyota RWD: 2005 & Up Tacoma PreRunner
Toyota 4WD: 2005 & Up Tacoma

25480 APPLICATIONS

Lexus AWD: 2003 & Up GX
Toyota RWD/4WD: 2007 & Up FJ Cruiser
2003 & Up 4Runner

25485 APPLICATIONS

Toyota RWD/4WD: 2001 - 07 Sequoia
1999 - 06 Tundra

25490

APPLICATIONS

Toyota RWD/4WD:
2007 & Up Tundra
2008 & Up Sequoia



25540

NISSAN FRONT UPPER ARMS (PR)

Lifted Nissans often run out of factory adjustment when lift kits are installed. Additionally, the OEM upper control arm can contact the frame, limiting droop travel and causing unwanted noise vibration harshness. These heavy duty replacement arms feature drawn over mandrel tubing construction and use our patented adjustable ball joint and new **SpecRide™** bushings, allowing for greatly increased droop travel and easy alignment.

Patent No.
US 7,513,514 B

Front Adjustment range:

Camber $\pm 2.00^\circ$

Caster -1.0° to $+3.00^\circ$

Installation time: .8 hr/side

Required: 1 per axle

APPLICATIONS

Nissan: 2005 & Up Frontier
2005 & Up Pathfinder
2005 & Up Xterra
Suzuki: 2009 - 12 Equator

These arms feature our SpecRide™ bushings for a quieter, OEM style ride (see above).

1-800-525-6505

Call for your nearest distributor, product info or Technical Assistance • In the USA and Canada

www.specprod.com



Front Adjustment range:
Camber $\pm 2.00^\circ$
Caster -1.0° to $+3.00^\circ$
Installation time: .8 hr/side
Required: 1 per axle

APPLICATIONS

Chevrolet: 2014 & Up Colorado

These arms feature our SpecRide™ bushings for a quieter, OEM style ride (see pg, 56).

COLORADO ADJUSTABLE FRONT UPPER ARMS

Pair **25620**

Second-generation Chevy Colorado trucks run out of factory camber and caster adjustment when they are lifted. SPC's heavy duty forged replacement arms provide 0° to $+4^\circ$ caster change and $\pm 3^\circ$ camber change with a sealed adjustable ball joint and SpecRide™ bushings. SPC's patented truck arms, offer increased droop travel and free pivoting bushings in an easy to align remove and replace arm.

Patent No. US 7,513,514 B



Rear Adjustment range: Camber $\pm 1.25^\circ$
Installation time: .6 hr/side Req.: 1 per wheel

APPLICATIONS

Chrysler: 2003 - 07 Crossfire (Inc. SRT6)

Mercedes: 2001 - 07 C Class (W203)
1994 - 00 C Class (W202)
2003 - 09 CLK Class (W209)
1994 - 03 CLK Class (W208)
1996 - 02 E Class (W210)
1986 - 95 E Class (W124)
1999 - 02 SL Class (W129)
1998 - 11 SLK Class (R170, R171)



 **75990** - Ball joint press sleeves, pg 131
72509 - Ball joint press, pg 129



MERCEDES REAR BUSHINGS

28840

These adjustable bushings make rear camber change possible for many Mercedes vehicles. By replacing the outer bushing in the two rear upper control arms, you achieve up to $\pm 1.25^\circ$ of change. Stock bushings are easily removed using the Specialty Products #75990 bushing press adapters.



Front Adjustment range:
35075 Camber $+1.0^\circ$ (fixed)
35076 Camber $+2.0^\circ$ (fixed)
Installation time: .2 hr/side
Required: 1 kit per wheel

APPLICATIONS

Dodge: 2003 - 06 Sprinter Van
Freightliner: 2001 - 06 Sprinter Van
Mercedes: 2001 - 06 Sprinter Van

SPRINTER VAN FRONT ADJUSTER KIT

35075
35076

These shim kits let you change front camber on Dodge, Freightliner and Mercedes Sprinter Vans. Their unique design allows the technician to 'lock' the alignment settings. These shims install quickly and easily for time saving adjustments.



Front Adjustment range:
Camber $\pm 3.0^\circ$
Installation time: .4 hr/axle
Required: 1 kit per axle

APPLICATIONS

Dodge: 2007 - 13 Sprinter Van
Freightliner: 2007 - 13 Sprinter Van
Mercedes: 2007 - 13 Sprinter Van

SPRINTER FRONT ADJUSTER KIT (PR)

35077

Camber change on the 2007 and up Sprinter Van is quick, easy, and locked in with this SPC cam kit. Get up to $\pm 3.0^\circ$ camber change by simply removing the upper OE bolt, loosening the lower bolt, installing and adjusting this cam kit to the desired change and then tightening everything to specification. This is an easy fix for camber issues and a perfect companion sale for any strut job. Save time, money and effort by making aligning this two bolt strut vehicle a one man job. Kit includes two cams, one for each corner.



35080 - 1mm **35081** - 2mm
35082 - 4mm
FRONT APPLICATIONS
Nissan RWD/4WD: 1987 - 95
Pathfinder; 1986 - 97 Pickup

NISSAN CAM/CAS SHIMS

35080
SERIES

These shims install between the upper control arm mount and shaft to adjust Pathfinders and Pickups.
6 Shims per package



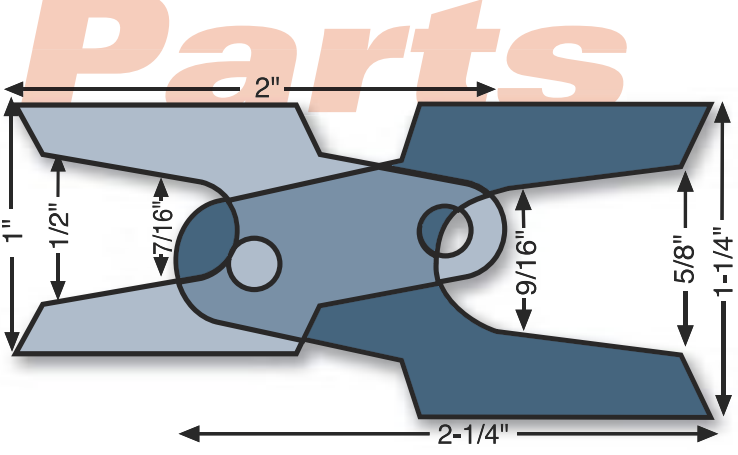

Camber/Caster Duo-Fit

APPLICATIONS: Buick, Chevrolet, Ford, Lincoln, Mercury, Pontiac, Oldsmobile

Part No.	Thick.	Opening	Qty
37100	1/64"	7/16" to 1/2"	25
37101	1/32"	7/16" to 1/2"	25
37102	1/16"	7/16" to 1/2"	25
37103	1/8"	7/16" to 1/2"	25

APPLICATIONS: AMC, Buick, Cadillac, Chevrolet, Lincoln, Oldsmobile, Pontiac, Trucks

Part No.	Thick.	Opening	Qty
37104	1/64"	9/16" to 5/8"	25
37105	1/32"	9/16" to 5/8"	25
37106	1/16"	9/16" to 5/8"	25
37107	1/8"	9/16" to 5/8"	25

Camber/ Caster Shim Sets

37150 DUO-FIT SET

Filled with 200 shims - 25 each of all Duo-Fit styles and sizes above (37100 through 37107). Handy chart inside the lid makes reordering and organization simple. Comes in a durable plastic case.



37150 Duo-Fit

47700 SLA SET

These camber/caster shims (Previous page and below) are now available in a corrugated box set to help you organize all of your shims. Covering both cars and trucks this set is perfect for inventory control.



47700 SLA

Contains 50 Each: 37105, 37106, 37107, 47151, 47152, 47153, 47181, 47182, 47183, 47766, 47767, 47768, 47775, 47776, 47777

Camber/ Caster Shims

47142 - 47143 'BS'

Universal 1/2" slot shim	Part #	Thick.	Qty
	47142	1/16"	25
	47143	1/8"	25

47180 - 47184 'N'

Universal 1/2" slot shim	Part #	Thick.	Qty
	47180	1/64"	50
	47181	1/32"	50
	47182	1/16"	50
	47183	1/8"	50
	47184	3/16"	50

47150 - 47153 'US'

5/8" open. APPS. Control arm shaft mount bolts up to 5/8" dia.	Part #	Thick.	Qty
	47150	1/64"	50
	47151	1/32"	50
	47152	1/16"	50
	47153	1/8"	50

47762 - 47764 'X'

7/16" open. APPS. Control arm shaft mount bolts up to 7/16" dia.	Part #	Thick.	Qty
	47762	1/16"	50
	47763	1/8"	50
	47764	3/16"	50

47765 - 47769 'CT'

1/2" open. for imports APPS. Control arm shaft mount bolts up to 7/16" dia.	Part #	Thick.	Qty
	47765	1/64"	50
	47766	1/32"	50
	47767	1/16"	50
	47768	1/8"	50
	47769	3/16"	50

47775 - 47778 'CC'

9/16" open. H/D Trucks APPS. Control arm shaft mount bolts up to 9/16" dia.	Part #	Thick.	Qty
	47775	1/32"	50
	47776	1/16"	50
	47777	1/8"	50
	47778	3/16"	25

Including 1/2 ton - 1 ton Chevrolet GMC trucks, HD service.

SHIMS SHOWN ACTUAL SIZE

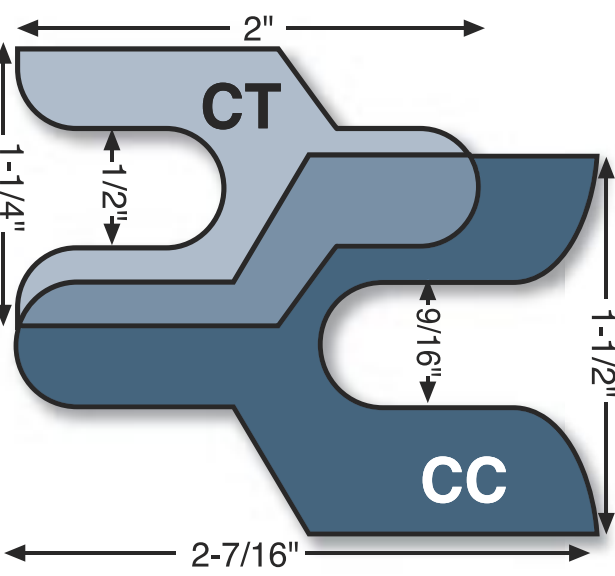
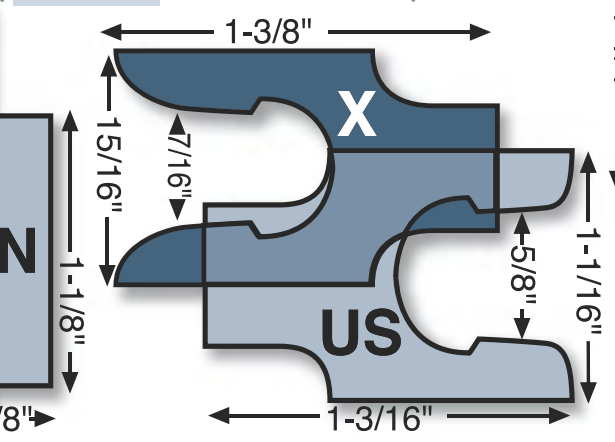
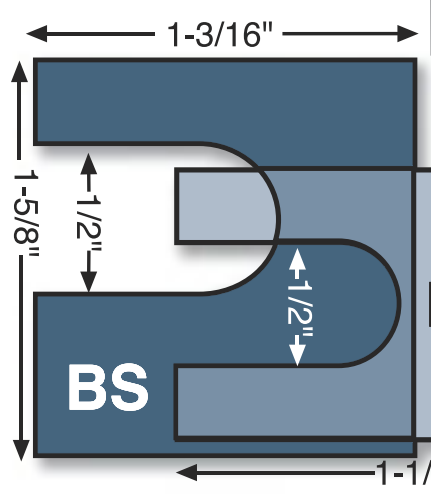

47170 SERIES



CORVETTE TOE SHIMS

These shims are designed to adjust rear toe on C2/C3 Corvette models. **6 Shims per package**

47171 - 1/32" 47172 - 1/16"
47173 - 1/8"
REAR APPLICATIONS
Chevrolet: 1963 - 82 Corvette

47240 - 1/32" 47241 - 1/16"
47242 - 1/8"

Adjustment range: 1/32" to 1/8"
Installation time: .3 hr/side

APPLICATIONS

Jeep: 1984 - 01 Cherokee
1985 - 92 Comanche
1993 - 04 Grand Cherokee
1984 - 93 Wagoneer

JEEP CASTER SHIMS

These shims provide positive caster changes on early model downsize Jeeps by installing them between the lower control arm and the frame bracket. Stackable for larger changes.

6 Shims per package

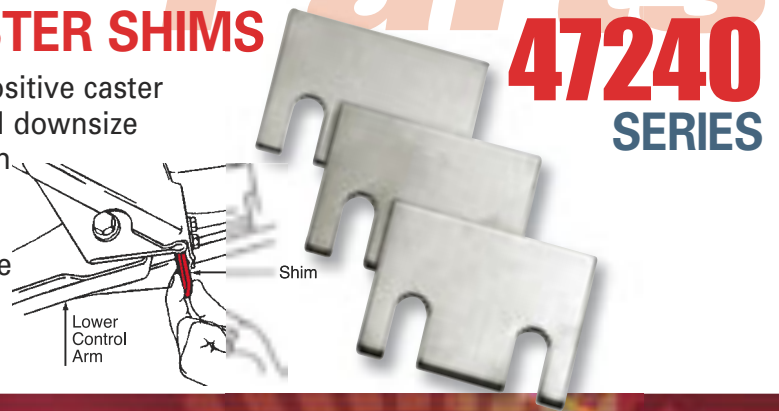

Front Adjustment range:

Camber $-.50^{\circ}$ to $+3.50^{\circ}$
Caster -1.00° to $+2.00^{\circ}$

Installation time: .7 hr/side

Required: 1 per wheel

APPLICATIONS

Acura: 1996 - 00 EL
Honda: 1996 - 00 Civic

Replacement ball joint - #67245 available, pg 64

FRONT CAMBER/CASTER CONTROL ARM

This OE type arm has a screw-type adjuster to easily and accurately change camber and caster while viewing live readings from the alignment machine. For stock height or lowered vehicles.

Comes completely assembled including ball joint, sliding plate, adjustment mechanism, and quiet, factory style, rubber bushings.



Installation time: .5 hr/axle

Required: 1 kit per axle

NOTE: Allow extra time for rusted bolts. New, longer U-Bolts may be required.

APPLICATIONS

63020 - 2-3/8" Width

Vehicles with 2-3/8" wide to 2-3/4" wide leaf springs inc. 60mm, 65mm and 70mm leaf springs of import trucks. All passenger vehicles with rear leaf springs.

63030 - 3" Width

Vehicles with 3", 3-1/2" and 3-5/8" wide leaf springs including 80mm, 90mm, and 100mm wide leaf springs.

THRUST ALIGNMENT PLATE

Our patented thrust alignment plate will allow for corrections of setback and thrust angle on most vehicles with rear leaf springs. Installation is made by loosening the U-bolts holding the leaf spring to the axle, installing the alignment plate between the axle and leaf spring and re-tightening the U-bolts. Widths are available in 2-3/8" and 3", and each kit comes with multiple parts to provide coverage of most vehicles with rear leaf springs, including all early model passenger cars.

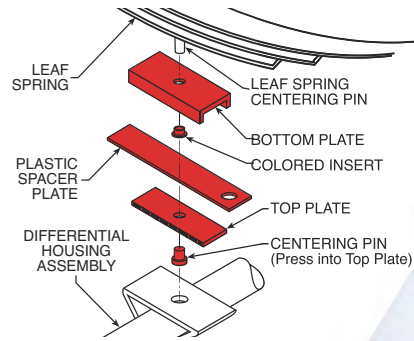

This is THE kit to correct Thrust Angle!

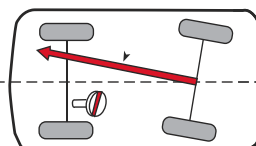

63020
63030

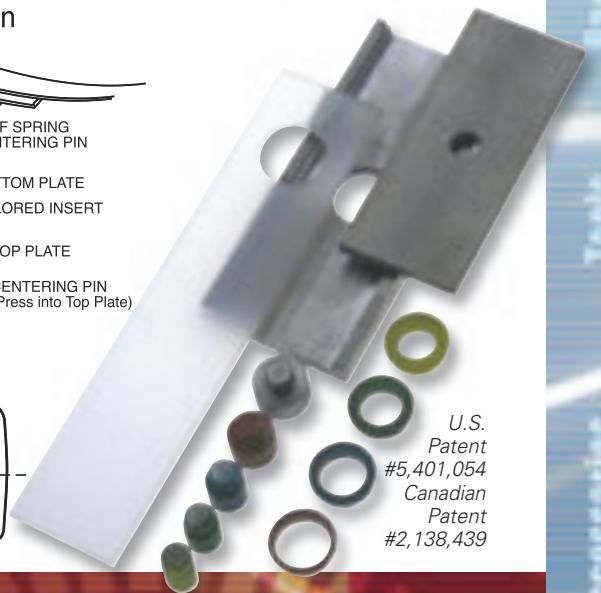

U.S. Patent #5,401,054
Canadian Patent #2,138,439

Front Adjustment range:

Camber $\pm 2.0^{\circ}$ Caster $\pm 1.5^{\circ}$

Installation time: .6 hr/side

Required: 1 per wheel

66040 APPLICATIONS

Chrysler: 2005 - 08 300C RWD
Dodge: 2008 - 08 Challenger
2006 - 08 Charger RWD
2005 - 08 Magnum RWD

66045 APPLICATIONS

Chrysler: 2009 & Up 300C RWD
Dodge: 2009 & Up Challenger
2009 & Up Charger RWD

Note: NOT for AWD vehicles.

CHRYSLER/DODGE ARM

This adjustable front control arm fits these popular Dodge and Chrysler vehicles and provides both camber and caster changes. Easy to install and even easier to adjust this is the perfect kit for standard alignment issues as well as special suspension tuning problems that occur when you lower these vehicles for performance or appearance. Our tubular design incorporates our low-profile adjustable ball joint.



Patent No. US 7,513,514 B



66050

CHRYSLER/DODGE REAR CAMBER KIT

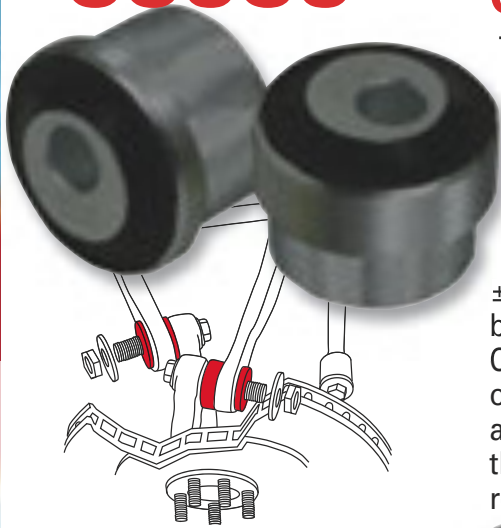

This kit combines our previous four kits into one – allowing adjustment of rear camber on the Chrysler LX platform cars regardless of model year and the complication that Chrysler used two different bushing sizes over the years. These “set-at-install” bushings can be clocked to provide up to $\pm 1.5^\circ$ of adjustment by replacing the outboard bushings on both upper control arms of all Chrysler LX-based cars regardless of aluminum or steel arm construction. By using the #66025 adapter along with the #40920 bushing press, these bushings can be installed without removing the control arms.

Rear Adjustment range:
Camber $\pm 1.50^\circ$

Installation time: .6 hr/side

Required: 1 kit per wheel

APPLICATIONS

- Chrysler:** 2005 & Up 300C
2004 - 08 Pacifica
- Dodge:** 2009 & Up Challenger
2006 & Up Charger
2005 - 08 Magnum



40920 - Performance Ball Joint Press, pg 125
66025 - Bushing Press Sleeves, pg 128

67010

NISSAN EZ ARM XR™

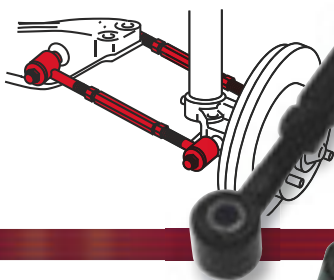

Our Nissan arm is for vehicles that have been lowered for performance and for those that retain the stock ride height. Simply replace the non adjustable OE arm with the EZ Arm XR, and you can adjust the rear camber.

** For positive camber changes larger than 2.75° install two (2) EZ Arms™ on each side.*

Rear Adjustment range:
Camber -2.00° to $+2.75^\circ$ *

Installation time: .8 hr/side

Required: 1 per wheel

APPLICATIONS

- Nissan:** 1985 - 94 Maxima
1987 - 92 Stanza

67015

CHRYSLER/DODGE EZ ARM XR™



This fully adjustable EZ Arm provides rear camber changes of $\pm 2.5^\circ$. From street to track our adjustable control arm offers simple installation and adjustment for optimal performance.

Rear Adjustment range:
Camber $\pm 2.50^\circ$

Installation time: .5 hr/side

Required: 1 per wheel

APPLICATIONS

- Chrysler:** 2007 - 10 Sebring
Dodge: 2008 - 10 Avenger
2009 - 10 Journey

67018

CHRYSLER JC/JS ARM XR™



This fully adjustable trailing link provides $\pm 4^\circ$ camber change for the rear of the Chrysler 200, Dodge Avenger and Dodge Journey. The simple to install "remove and replace" kit provides a lifetime of adjustability to maximize tire life and dial in handling.

This arm features our new OE style xAxis™ ball joint to match chassis design parameters and OE ride quality. See Page 116 for more on our cross axis style ball joints.

Rear Adjustment range:
Camber $\pm 4.00^\circ$

Installation time: .5 hr/side

Required: 1 per wheel

APPLICATIONS

- Chrysler:** 2011 & Up 200
Dodge: 2011 & Up Avenger
2011 & Up Journey

67020

CHRYSLER LH EZ ARM XR™



Adjust rear camber on 1993 - 97 Chrysler LH Bodies with this control arm. Simply replace the non adjustable OE arm with the EZ Arm XR, and you can adjust the rear camber. For 1998 - 04 use #67080.

** For positive camber changes larger than 1.00° install two (2) EZ Arms™ on each side.*



55600 - Check out our Rear Toe Tool for these LH Bodies - pg 127

Rear Adjustment range:
Camber -2.00° to $+1.00^\circ$ *

Installation time: .8 hr/side

Required: 1 per wheel

APPLICATIONS

- Chrysler:** 1993 - 97 Concorde,
1994 - 97 LHS,
New Yorker (FWD)
- Dodge:** 1993 - 97 Intrepid
Eagle: 1993 - 97 Vision

Rear Adjustment range:
Camber $\pm 3.50^\circ$

Installation time: .8 hr/side

Required: 1 per wheel

APPLICATIONS

Chrysler: 2004 - 06 Sebring Sedan
Dodge: 2004 - 06 Stratus Sedan

STRATUS AND SEBRING EZ ARM XR™

Adjust rear camber on 2004 - 06 Sebring and Stratus sedans up to 7° with this control arm. Simply replace the non-adjustable OE arm with the EZ Arm XR, and you can adjust the rear camber.



67025

Rear Adjustment range:
Camber -2.00° to $+5.00^\circ$

Installation time: .5 hr/side

Required: 1 per wheel

APPLICATIONS

Acura: 1996 - 00 EL
1990 - 01 Integra
Honda: 1988 - 00 Civic
1997 - 01 CR-V
1988 - 92 CRX
1992 - 97 Del Sol

HONDA/ACURA REAR EZ ARM XR™

For popular Honda Civics and Acura Integras. These arms are for vehicles that retain the stock ride height or have been lowered for performance. Simply replace the OE arm with the EZ Arm XR, and you can adjust the rear camber from -2.0° to $+5.0^\circ$.



67030

NOTE: Some vehicles may need longer bolts when installing this arm. Use set #73415 found on page 77.

Rear Adjustment range:
Camber -2.00° to $+3.50^\circ$

Installation time: .5 hr/side

Required: 1 per wheel

APPLICATIONS

Acura: 1996 - 99 CL
1996 - 98 TL
1992 - 94 Vigor
Honda: 1990 - 97 Accord

HONDA/ACURA REAR EZ ARM XR™

These arms correct rear camber on stock ride height vehicles and vehicles that have been lowered up to 1.5" with an adjustment range of -2.0° to $+3.5^\circ$. 67065 comes with a non-directional ball joint preinstalled. (Extreme drops - use #67265 page 64).



67065

Replacement ball joint - #67075 available, page 62.

SPC Performance has been involved with one of the biggest names in SCCA racing, HART (Honda America Race Team), for almost a decade. This factory sponsored team has put together a long and impressive series of wins and is an important partner when we design parts for the newest Honda/Acura platforms.

In 2012 HART drivers Chad Gilsinger, Jeremy Lucas and Luke Wilwert put together many wins and fastest times. The team was able to grab three podium results including two wins and two pole positions in just a partial season.

In 2013 HART is debuting a new Honda Civic Si and the team knows how important fine tuning the suspension components is to turning in competing times on the track. "Turning this sporty coupe into a car ready for the track took some effort from the team but also a lot of help from our partners. One major key to any race car is handling and with the help from SPC we were able to have the tuning parts available to dial in the car's handling."

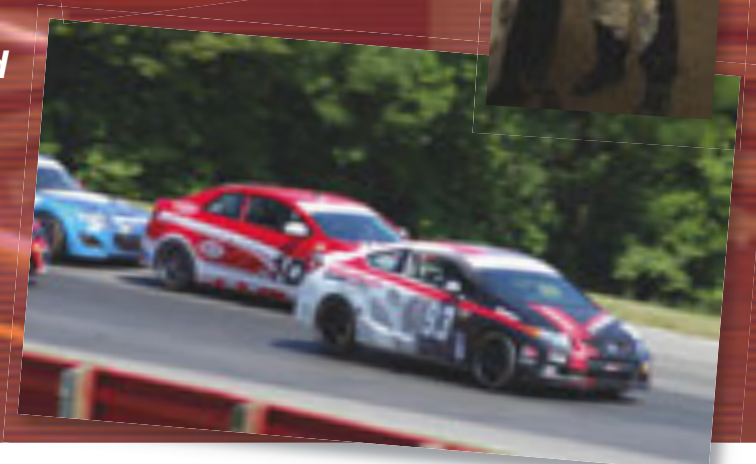
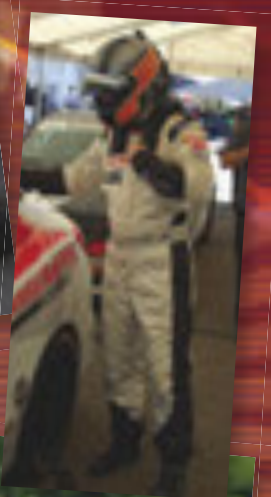

Parts

67070

ESCORT TOE ARMS

A replacement arm to change toe -1.0° to +1.5° on these vehicles.

PART NO. 21030
Replacement Spindle Bolts

For replacing rusted OE spindle to trailing arm bolts, fits 1991 - 94 Escorts and Tracers.

Rear Adjustment range:
Toe -1.00° to +1.50°

Installation time: .5 hr/side Req.: 1 per wheel

APPLICATIONS

Ford: 1991 - 96 Escort
Mazda: 1990 - 94 323
Mercury: 1991 - 94 Tracer



67075

REPLACEMENT BALL JOINT

This ball joint can be used for 67065 and 67265 EZ Arms XR™, as well as a replacement ball joint for several Honda and Acura vehicles.

40920 - Perf. Ball Joint Press, pg 125

We have adjustable ball joints for these vehicles and more - check them out on pages 63 and 65.

Rear/Front Upper Replacement Part

Installation time: .6 hr/side Req.: 1 per wheel

APPLICATIONS

REAR Acura: 1996 - 04 CL; 1996 - 08 TL
1992 - 94 Vigor
REAR Honda: 1990 - 02 Accord
FRONT Acura: 1996 - 04 CL; 1999 - 08 TL
FRONT Honda: 1998 - 02 Accord
1996 - 00 & 1988 - 91 Civic
1989 - 92 CRX
1995 - 98 Odyssey



67080

CHRYSLER LH EZ ARM XR™

Adjust rear camber on 1998 to 2004 Chrysler LH Bodies with this control arm. Simply replace the OE arm with the EZ Arm XR, and you can adjust the rear camber.

** For positive camber changes larger than 1.0° install two (2) EZ Arms™ on each side.*

55700 - Check out our Front Toe Tool for these LH Bodies - pg 127

Rear Adjustment range:
Camber -2.00° to +1.00°*

Installation Time: .8 hr/side

Required: 1 per wheel

APPLICATIONS

Chrysler: 1999 - 04 300M
1998 - 04 Concorde
1998 - 01 LHS
Dodge: 1998 - 04 Intrepid

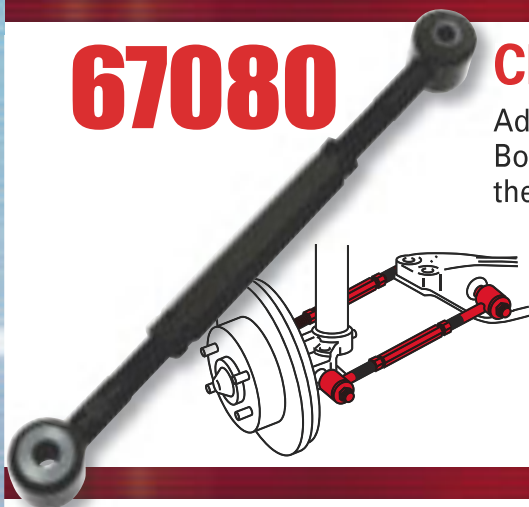

67090 67095

HONDA/ACURA REAR EZ ARM XR™

For many Hondas and Acuras, these arms have an O.E. style ball joint integrated into a complete arm assembly and they have a full 6° range of rear camber change with our turnbuckle adjustment system.

Rear Adjustment range:
Camber -2.00° to +4.00°

Installation Time: .5 hr/side

Required: 1 per wheel

APPLICATIONS

67090
Acura: 2001 - 94 CL
1996 - 04 RL
1999 - 03 TL
Honda: 1998 - 02 Accord
67095
Acura: 2004 - 08 TL

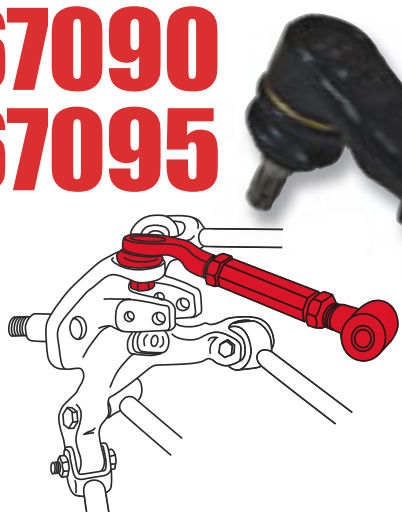

67110

BMW REAR CAMBER ARM

For BMW E36, E46 and E85 bodied vehicles this tubular style arm is great when lowering this popular vehicle, or for correcting rear camber on stock vehicles.

Rear Adj. range: Camber -1.00° to +3.00°

Installation time: 1.3 hr/side Req.: 1 per wheel

APPLICATIONS

BMW: 2000 - 06 3 Series Coupe and Convertible (E46)
1999 - 05 3 Series Sedan and Wagon (E46)
1992 - 99 3 Series 318, 323 and M3 (E36)
2003 - 08 3 Series Z4 (E85)

For high performance applications check out our billet aluminum arm (#72110) on page 74.

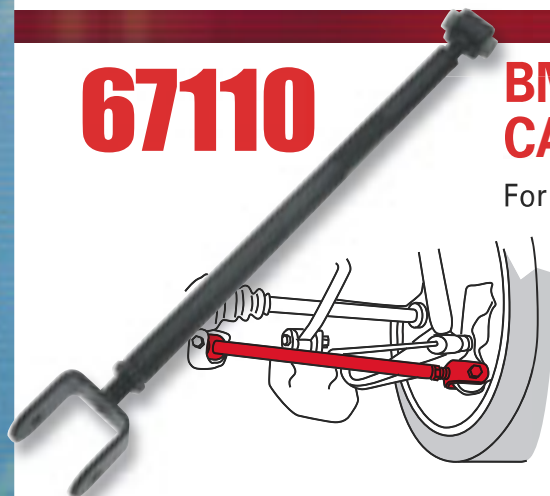

1-800-525-6505

Call for your nearest distributor, product info or Technical Assistance • In the USA and Canada

www.specprod.com



Adjustment range: Camber $\pm 1.50^\circ$

Installation time: .6 hr/side Required: 1 per wheel

APPLICATIONS FRONT

67115 Ford: 2006 - 12 Fusion Mazda: 2003 - 08 Mazda6
Lincoln: 2007 - 12 MKZ Mercury: 2006 - 11 Milan
2006 Zephyr

67125 Acura: 1996 - 04 CL (w/35.3mm Ball Joint Dia.)
1996 - 99 CL (w/35.3mm Ball Joint Dia.)
1999 - 08 TL; 1996 - 98 TL 2.5; 2004 - 08 TSX
Honda: 1998 - 02 Accord; 1989 - 91 Civic; 1989 - 92 CRX

67135 Acura: 1996 - 00 EL; 1990 - 01 Integra; 1991 - 96 Legend
1996 - 04 RL; 1996 - 98 TL 3.2; 2009 - 13 TSX
Honda: 2008 - 12 Accord/Crosstour; 1992 - 00 Civic
1997 - 01 CRV; 1992 - 97 Del Sol; 1997 - 02 Prelude

67145 Acura: 1996 - 99 CL (w/33.5mm Ball Joint Dia.)
Honda: 1990 - 97 Accord; 1995 - 98 Odyssey
Isuzu: 1996 - 99 Oasis

67155 Honda: 1997 - 02 Prelude SH

67165 Acura: 1992 - 94 Vigor
Honda: 1992 - 96 Prelude; 1992 - 94 Prelude 4WS

67170 Chrysler: 1995 - 00 Sebring Coupe
Dodge: 1995 - 00 Avenger
Eagle: 1995 - 98 Talon
Mitsubishi: 1995 - 99 Eclipse; 1994 - 98 Galant

67180 Chrysler: 1995 - 00 Cirrus; 2001 - 06 Sebring Sedan
1996 - 06 Sebring Conv.
Dodge: 1995 - 06 Stratus Sedan
Plymouth: 1996 - 00 Breeze

67190 Hyundai: 2006 Azera (before 10/31/06)
1999 - 05 Sonata (before 9/21/06); 2001 - 06 XG300/350
Kia: 2004 - 06 Amanti; 2001 - 06 Optima

67195 Hyundai: 2007 & Up Azera (after 10/31/06)
2006 & Up Sonata (after 9/21/06)
Kia: 2006 - 11 Amanti

APPLICATIONS REAR

67155 Honda: 1995 - 98 Odyssey
Isuzu: 1996 - 99 Oasis

67165 Honda: 1992 - 02 Prelude

See our Adjustable Ball Joint for Honda S2000 pg 64

See our Adjustable Ball Joint for Lexus on pg 68

www.SPC-TV.com is the best way to get all the latest info from Specialty Products. Look for the TV icon for your direct link from catalog to our install videos. Just scan and watch!

Rear Adjustment range:

1 Kit per Axle Toe Only $\pm 1.50^\circ$

2 Kits per Axle Toe $\pm 3.00^\circ$
Camber $\pm 3.00^\circ$

Required: 1 or 2 per Axle (above)

Installation time: .4 hr/side

APPLICATIONS

Dodge/Plymouth: 1994 - 06 Neon
Including SRT 4

Note: Each kit includes 2 arms

NEON EZ ARM XR™

This control arm makes it possible to adjust rear camber and toe on all production models of Dodge and Plymouth Neons, including the SRT 4. This arm may be used on vehicles that have been lowered for performance and appearance as well as vehicles that have retained their stock ride height. When two arms are used on each side you can change both camber and toe $\pm 3.0^\circ$. If you use just one arm on each side only $\pm 1.5^\circ$ toe change is available.

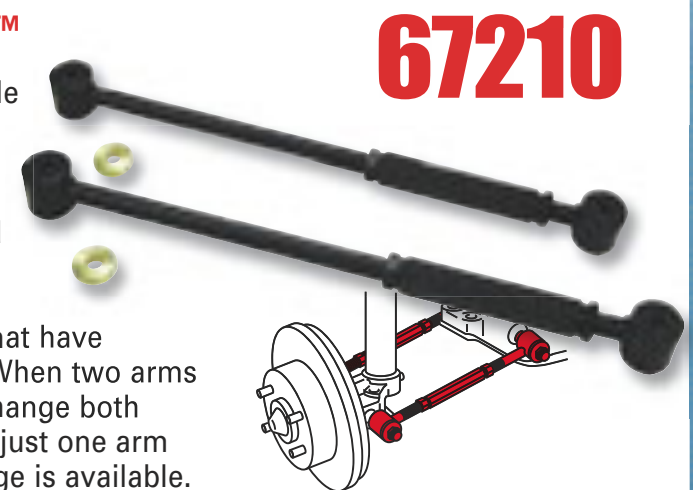

67210

ADJUSTABLE BALL JOINT

67115 67125 67135 67145 67155 67165 67170 67180 67190 67195

These adjustable upper ball joints make front camber adjustments for many vehicles with upper control arms. By replacing the factory ball joint, this sliding ball joint allows for greater changes than previously available. With an OE quality replacement ball joint, this sliding plate assembly is perfect for vehicles that have been lowered for performance, or retain the factory ride height. For changes greater than $+1.5^\circ$ check out our Extended Range Ball Joints on page 65.

- Best clearance in the industry
- Exclusive 'low-profile' design
- OEM strength built-in
- Preferred by professional installers



40920 - Perf. Ball Joint Press, pg 125

Parts

67220

HONDA S2000 BALL JOINT

Designed specifically for the S2000, this ball joint corrects camber on both the front and rear. An OE quality ball joint, this adjustable part corrects camber up to $\pm 1.5^\circ$.



***NOTE:** The rear applications are ONLY for vehicles equipped with 17" rims or larger. Front applications work with all stock rim sizes and larger.

Front/Rear* Adjustment range:
Camber $\pm 1.5^\circ$

Installation Time: .6 hr/side

Required: 1 per wheel

APPLICATIONS



40920 - Perf. Ball Joint Press, pg 125

Honda:
2000 - 09 S2000

67230

HONDA/ACURA EZ ARM XR™

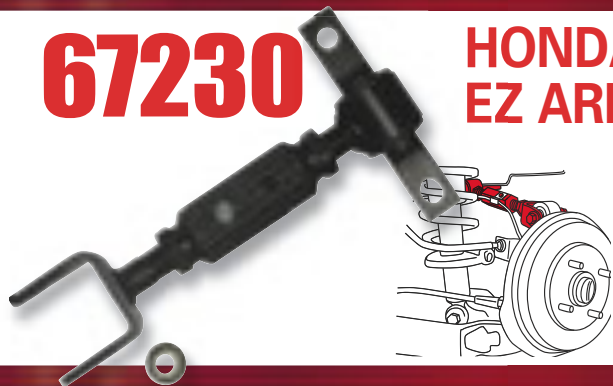

This EZ Arm corrects rear camber on Honda's redesigned 2001 - 05 Civic along with the 2002 - 07 Acura RSX. Simply replace the OE arm with this arm, perfect for stock height and lowered vehicles.

Rear Adjustment range:
Camber -4.00° to $+6.00^\circ$

Installation Time: .5 hr/side

Required: 1 per wheel

APPLICATIONS

Acura: 2001 - 05 EL; 2002 - 07 RSX
Honda: 2001 - 05 Civic

67245

REPLACEMENT BALL JOINT



This can be used for 62010 as well as a replacement part.



40920 - Perf. Ball Joint Press, pg 125

Front Upper Replacement Part

Installation time: .6 hr/side Req.: 1 per wheel

APPLICATIONS

Acura: 1990 - 01 Integra, 1996 - 98 3.2TL
1996 - 01 RL, 1991 - 96 Legend
Honda: 1997 - 02 Prelude, 1992 - 97 Del Sol
1997 - 01 CR-V, 1992 - 00 Civic

67265

EXTENDED RANGE HONDA/ACURA REAR EZ ARM XR™



These arms correct rear camber on vehicles that have been lowered up to 3.0" with an adjustment range of -2.0° to $+3.5^\circ$. The "bent" design of the arm gives extra clearance. 67265 comes with a non-directional ball joint preinstalled. (Stock vehicles - use 67065 page 61). Replacement Ball Joint #67075 (page 62).

Rear Adjustment range:
Camber -2.00° to $+3.50^\circ$

Installation Time: .5 hr/side

Required: 1 per wheel

APPLICATIONS

Acura: 1996 - 99 CL
1996 - 98 TL
1992 - 94 Vigor
Honda: 1990 - 97 Accord

67270

SATURN REAR EZ ARM XR™



Designed to adjust camber on the new Saturn "L" series cars, this arm is easy to install and provides rear camber adjustment for the life of the vehicle. With its 8° adjustment range this arm can handle extreme amounts of camber changes that may be needed if you lower the Saturn "L".

Rear Adjustment range:
Camber $\pm 4.00^\circ$

Installation Time: .8 hr/side

Required: 1 per wheel

APPLICATIONS

Saturn: 2000 - 05 L-Series

67285

ESCAPE/TRIBUTE REAR CAMBER ARM

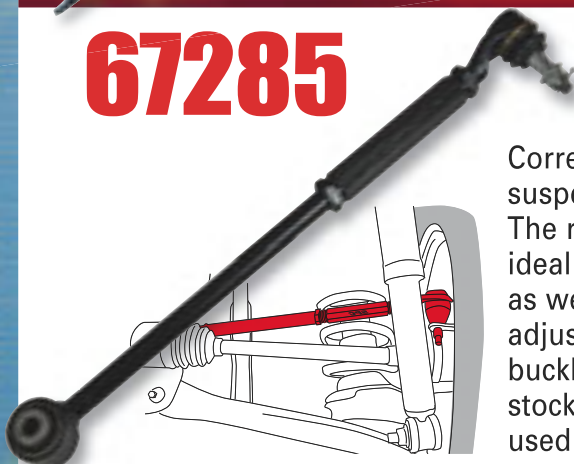

Correct camber on previously non-adjustable suspensions with this adjustable control arm. The remove and replace design makes the arm ideal for quick and easy alignment adjustment as well as simple chassis part replacement. The adjustable arm has an easy to access turn-buckle design that adjusts camber $\pm 2.0^\circ$, stock toe adjustments can then be used to complete the alignment.

Rear Adjustment range:
Camber $\pm 2.00^\circ$

Installation time: .8 hr/side

Required: 1 per wheel

APPLICATIONS

Ford 4WD/RWD:
2001 - 12 Escape
Mazda 4WD/RWD:
2001 - 11 Tribute



Rear Adjustment range: Camber -2.00° to +4.00°

Installation Time: .5 hr/side Req.: 1 per wheel

APPLICATIONS

- Acura:** 2001 - 06 MDX
2004 - 08 TSX
- Honda:** 2003 - 07 Accord
1999 - 04 Odyssey
2003 - 08 Pilot



HONDA/ACURA EZ ARM XR™

67290

These rear arms are for Accords, Pilots and more. An O.E. ball joint is integrated into this arm. Perfect for stock height and lowered vehicles.



JOUNCE SPACERS (4)

67300

Dial in your up-travel stops on coil over suspensions. These easy to use Jounce Bumper Spacers allow you to control up-travel by simply placing urethane spacers between your factory bump stop and the shock body. The closed wedge design allows you to install the spacers without removing the spring or disassembling your strut. Take them out as easily as you put them in if you want to increase up travel. Each of the 4 spacers will decrease your up-travel by 8mm at the strut.



These Jounce Spacers are now featured on our 72125, 72130 Nissan arms and our 23410 Jeep Adjustable Ball Joint

Adjustment range: Camber +1.50° to +3.00°

Installation time: .6 hr/side Required: 1 per wheel

APPLICATIONS FRONT

- 67320 Acura:** 1996 - 04 CL (w/35.3mm Ball Joint Dia.)
1996 - 99 CL (w/35.3mm Ball Joint Dia.)
1999 - 08 TL; 1996 - 98 TL 2.5; 2004 - 08 TSX
- Honda:** 1998 - 02 Accord; 1989 - 91 Civic; 1989 - 92 CRX

- 67330 Acura:** 1996 - 00 EL; 1990 - 01 Integra; 1991 - 96 Legend
1996 - 04 RL; 1996 - 98 TL 3.2; 2009 - 13 TSX
- Honda:** 2008 - 12 Accord/Crosstour; 1992 - 00 Civic
1997 - 01 CRV; 1992 - 97 Del Sol; 1997 - 02 Prelude

- 67340 Acura:** 1996 - 99 CL (w/33.5mm Ball Joint Dia.)
Honda: 1990 - 97 Accord; 1995 - 98 Odyssey
Isuzu: 1996 - 99 Oasis

- 67350 Honda:** 1997 - 02 Prelude SH

- 67360 Acura:** 1992 - 94 Vigor
Honda: 1992 - 96 Prelude; 1992 - 94 Prelude 4WS

- 67370 Chrysler:** 1995 - 00 Sebring Coupe
Dodge: 1995 - 00 Avenger
Eagle: 1995 - 98 Talon
Mitsubishi: 1995 - 99 Eclipse; 1994 - 98 Galant

APPLICATIONS REAR

- 67360 Honda:** 1992 - 02 Prelude

See our Adjustable Ball Joint for Honda S2000 (Part No. 67220 - pg 64)



40920 - Perf. Ball Joint Press, pg 125

EXTENDED RANGE ADJUSTABLE BALL JOINT

67320 67330 67340 67350 67360 67370

Able to change camber from +1.50° up to +3.0° these ball joints are perfect for lowered vehicles. For changes less than +1.5° check out our Adjustable Ball Joints on page 63.

These ball joints have the best clearance in the industry - thanks to our exclusive 'low-profile' design. And with OEM strength built in, our ball joints are the ones that more pro installers use.

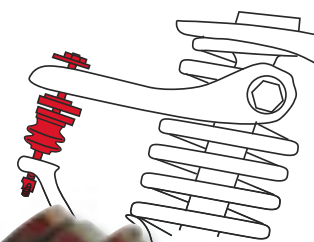

Rear Adjustment range:
Camber -2.00° to +4.00°

Installation Time: .5 hr/side

Required: 1 per wheel

APPLICATIONS

- Honda:** 1986 - 89 Accord

ACCORD REAR EZ ARM XR™

67395

This arm is for 86 - 89 Honda Accords. An OE style ball joint is integrated into this complete arm and it has a 6° range (-2.0° to +4.0°) of rear camber change.



Parts

67410

HYUNDAI/KIA REAR EZ ARM XR™



These adjustable rear upper control arm and toe cam kits, for many Hyundai and Kia models, will provide up to $\pm 2^\circ$ camber and $\pm 2^\circ$ toe change.

85130 - Rotary File, pg 133

Rear Adjustment range:
Camber $\pm 2.0^\circ$ /Toe $\pm 2.0^\circ$

Installation Time: .5 hr/side

Required: 1 per wheel

APPLICATIONS

Hyundai: 2007 - 10 Elantra
Kia: 2007 - 08 Optima
2007 - 12 Rondo

67420 67440

CELICA, FORD, MAZDA3, VOLVO, FORGED REAR CAMBER ARM

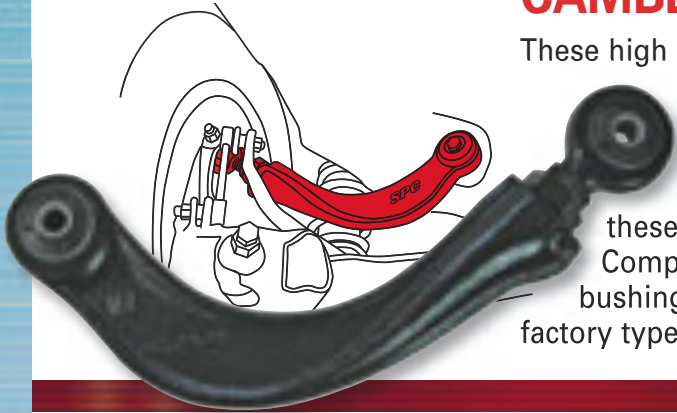

These high strength forged rear arms are perfect for tuners or installers that need extended camber ranges on these popular platforms. Complete with OE style bushings installed for a factory type ride.

Rear Camber Adjustment

Installation Time: .5 hr/side Req.: 1 per wheel

67420 Rear Camber -1.5° to $+5.0^\circ$

APPLICATIONS

Ford: 2013 & Up Escape; 2000 & Up Focus
Mazda: 2004 & Up Mazda3; 2006 & Up Mazda5
Volvo: 2008 & Up C30; 2006 & Up C70
2004 - 12 S40; 2004 - 11 V50

67440 Rear Camber $\pm 3.0^\circ$

APPLICATIONS

Toyota: 2000 - 05 Celica



67430

HONDA CR-V REAR EZ ARM XR™

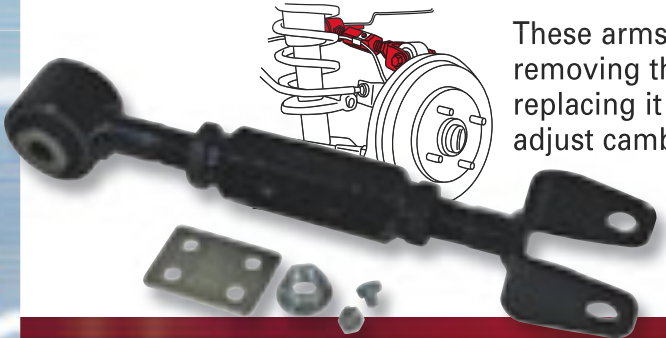

These arms fit popular CR-Vs and Elements. By removing the stock upper rear control arm and replacing it with the adjustable arm you can adjust camber either positive or negative with the turnbuckle adjuster. This arm can be used on vehicles with stock ride height or vehicles that have been altered for performance.

Rear Adjustment range:
Camber. -2.00° to $+4.00^\circ$

Installation time: .5 hr/side

Required: 1 per wheel

APPLICATIONS

Honda: 2002 - 06 CR-V
2003 - 11 Element

67455

DODGE/JEEP REAR CAMBER ARM

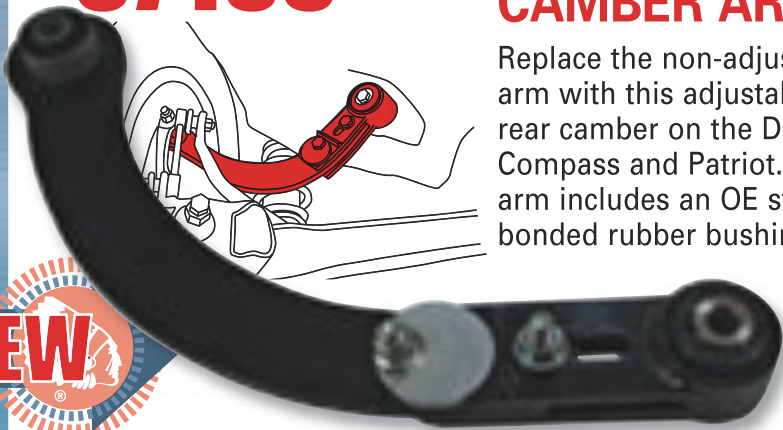

Replace the non-adjustable rear upper control arm with this adjustable arm to dial in $\pm 2^\circ$ of rear camber on the Dodge Caliber, Jeep Compass and Patriot. This remove and replace arm includes an OE style xAxis™ ball joint and bonded rubber bushing to match chassis design parameters and OE ride quality.

Rear Adjustment range:
Camber. $\pm 2.00^\circ$

Installation time: .5 hr/side

Required: 1 per wheel

APPLICATIONS

Dodge AWD/FWD:

2007 - 12 Caliber

Jeep AWD/FWD:

2007 & Up Compass
2007 & Up Patriot

Mitsubishi AWD/FWD:

2008 & Up Lancer
2007 & Up Outlander

NEW

This arm features our new OE style xAxis™ ball joint and bonded rubber bushing to match chassis design parameters and OE ride quality. See Page 116 for more on our cross axis style ball joints.

Patent Pending



SPC's engineers and techs are constantly looking at new platforms. When the new FR-S/BRZ was introduced we knew we had a rear camber arm that would fit the platform - but how to make it better? By using a stamped steel design with our new xAxis™ bushings our designers took our current part and fine tuned it for the performance market. See this arm on page 70.

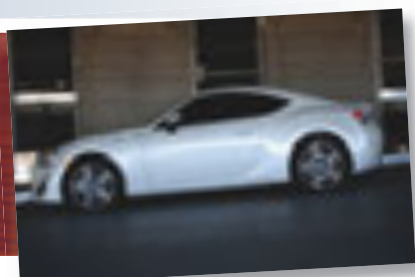

1-800-525-6505

Call for your nearest distributor, product info or Technical Assistance • In the USA and Canada

www.specprod.com



Rear Adjustment range:
Camber $\pm 1.25^\circ$

Installation time: .5 hr/side

Required: 1 per wheel

APPLICATIONS

Acura: 2013 & Up ILX

Honda: 2006 & Up Civic,
Civic Si, Civic Hybrid

CIVIC CAMBER BRACKET

67465

This rear bracket and bushing replaces the stock mount on '06 and up Honda Civics. By rotating the eccentric bolt/cam assembly in the bracket you can get $\pm 1.25^\circ$ of rear camber change. Use **#75980** bushing removal press sleeve set with the **#72509** ball joint press to remove the old bushing and to press in the new bushing.



75980 - Bushing Sleeves, pg 131
72509 - Ball Joint Press, pg 129



Rear Adjustment range:
Camber $\pm 3.0^\circ$

Installation time: .5 hr/side

Required: 1 per wheel

APPLICATIONS

Acura: 2013 & Up ILX

Honda: 2006 & Up Civic,
Civic Si, Civic Hybrid

HONDA CIVIC CAMBER ARM

67470

This remove and replace rear control arm for the '06 and up Honda Civic offers $\pm 3^\circ$ camber change. Forged with aircraft strength aluminum the arm is strong and functional with minimum weight. The double sleeve adjuster is easy to access and allows for on-car adjustment.

SPC
PERFORMANCE.

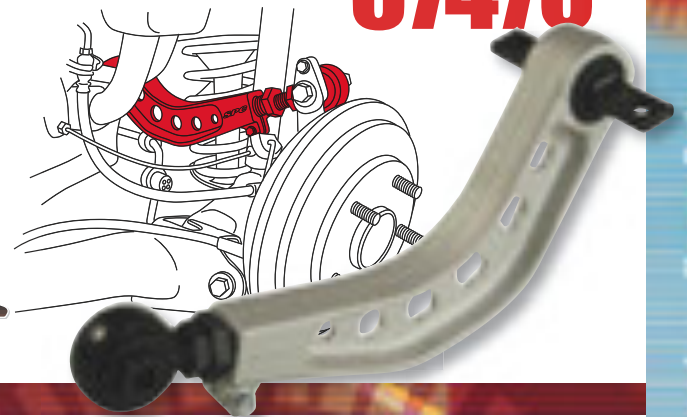

Rear Adjustment range:
(Includes the camber adjustment built-in from the factory)
Camber $+3.25^\circ$

Installation time: .5 hr/side

Required: 1 per wheel

APPLICATIONS

Scion: 2005 - 10 tC

SPC
PERFORMANCE.

SCION tC REAR ARM

67485

This fixed change arm is ideal for correcting excessive negative camber issues seen in lowered Scion tC's. The Scion tC comes from the factory with a cam bolt that provides $\pm 1.25^\circ$. This factory change is not enough change for lowered applications. By increasing the length of the rear upper control arm SPC Performance adds 2° positive camber to the rear suspension that can then be dialed in with the OEM cam bolt.

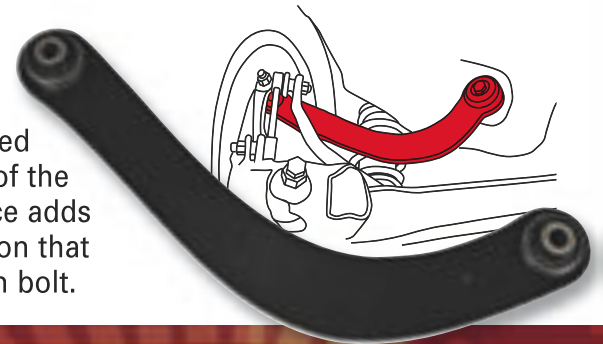

Rear Adjustment range:
Camber $\pm 2.00^\circ$

Installation time: .5 hr/axle

Required: 1 kit per wheel

APPLICATIONS

Honda: 2005 & Up Ridgeline

HONDA RIDGELINE REAR EZ ARM XR™

67490

This rear camber arm for the Honda Ridgeline has an O.E. style ball joint integrated into it and has a full 4° of camber change using our turnbuckle adjustment system.



Rear Adjustment range:
Additional Camber $+1.00^\circ$

Installation time: .6 hr/side

Required: 1 per wheel

APPLICATIONS

67510

Lexus: 1998 - 05 GS

67515

Lexus: 2001 - 05 IS

LEXUS REAR CAMBER KIT

67510

67515

This cam bolt and bracket kit provides an additional one degree of positive camber change. You will need to elongate the existing camber slot by using **85130** rotary files or equivalent. This is ideal for use on lowered vehicles along with our **67525** adjustable ball joint for front camber change (page 68).



85130 - Rotary File, pg 133



Parts

67520

LEXUS IS & GS ADJ. REAR CAMBER ARM

SPC's tried and proven adjustable rear arms allow camber changes up to $\pm 1.5^\circ$ (Limited only by the toe cam's range). With the correct camber dialed in you can set up the popular Lexus IS and GS for superior handling and extended tire life.

Rear Adjustment range:
Camber. $\pm 1.50^\circ$

Installation time: .5 hr/side

Required: 1 per wheel

APPLICATIONS

Lexus: 2006 - 12 GS
2006 & Up IS

NEW

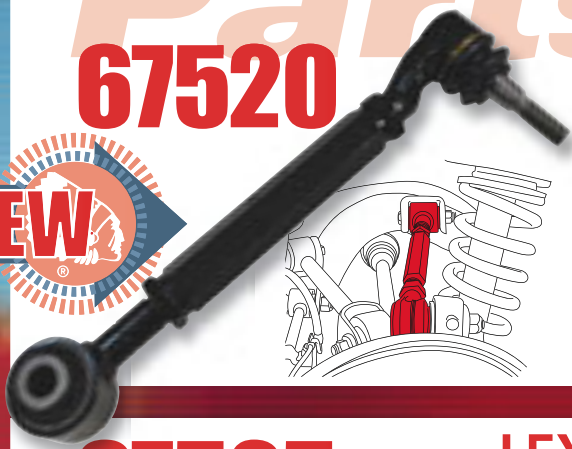

67525 67530

LEXUS GS/IS BALL JOINT

Designed specifically for the Lexus GS & IS, this ball joint corrects camber up to $\pm 1.5^\circ$. With an OE quality replacement ball joint, this sliding plate assembly is perfect for vehicles that have been lowered for performance, or retain the factory ride height.

Front Adjustment range:
Camber $\pm 1.5^\circ$

Installation Time: .6 hr/side

Required: 1 per wheel

APPLICATIONS

67525

Lexus: 2001 - 05 IS

67530

Lexus: 2006 - 12 GS
2006 & Up IS



 **40920 - Performance Ball Joint Press,**
pg 125



67540

ACCORD/TSX REAR ADJUSTABLE 3 ARM SET

The Honda Accord and Acura TSX Rear Adjustable Control Arm Set (3) provides; $\pm 3^\circ$ camber adjustment (when using all 3 arms), additional toe change, and ± 1 " set-back / wheel base adjustment. Whether you need alignment changes to adjust for ride height changes,

Rear Adjustment Range:

67540 (3 ARM SET)

Camber: $\pm 3.0^\circ$ /Toe: $\pm 1.0^\circ$

Setback: $\pm 1.0^\circ$

67545 Camber: $\pm 1.0^\circ$

67550* Setback: $\pm 1.0^\circ$

67555* Toe: $\pm 1.0^\circ$

*** 67550 and 67555 MUST be used with arm 67545**

Installation time:

67540 - .8 hr/side

67545 - .3 hr/side

67550 - .3 hr/side

67555 - .3 hr/side

Required: 1 per wheel

APPLICATIONS

Acura: 2009 & Up TL, TSX

Honda:

2008 & Up

Accord

2010 - 12

Crosstour

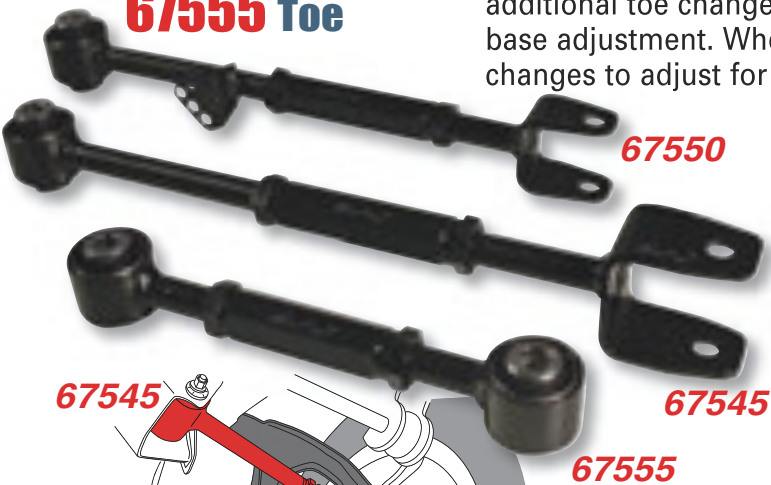

prepare for a weekend of road racing or correct suspension damage, this 3 piece arm set will provide maximum adjustability. *Attention: The sequence of arm adjustments made is extremely important when upgrading this multi-link system.*

See SPC-TV.com for in-depth information on this kit and how it will work in the Accord/TSX multi-link suspension.

67545 - REAR CAMBER ARM

The Honda Accord and Acura TSX Adjustable Rear Camber Arm by itself allows camber change of up to $\pm 1^\circ$. If more than 1° change is required toe arm #67555 and lateral arm #67550 may be required. This single arm is also an ideal replacement arm for a damaged OE arm. Attention: Toe will change as you adjust camber with this control arm.

67550 - REAR LATERAL ARM

The Honda Accord and Acura TSX Rear Adjustable Trailing Arm is an ideal replacement for a damaged OE component. Additionally, it will provide ± 1 " set-back/wheel base adjustment. This arm is necessary to correct set-back changes that the 67545 adjustable camber arm and 67555 Adjustable Toe Arm will create when adjusting camber and toe beyond $\pm 1^\circ$.

67555 - REAR TOE ARM

The Honda Accord and Acura TSX Rear Adjustable Toe Arm is an ideal replacement for a damaged OE toe arm. Additionally, it provides added toe change beyond what the OE Toe Cam offers. This arm will be necessary to correct toe changes that the 67545 adjustable camber arm will create when adjusting beyond $\pm 1^\circ$.

1-800-525-6505

Call for your nearest distributor, product info or Technical Assistance • In the USA and Canada

www.specprod.com



Rear Adjustment range:
Camber -2.00° to $+4.00^{\circ}$

Installation time: .5 hr/side

Required: 1 per wheel

APPLICATIONS

67570

Acura: 2007 & Up MDX
w/o Air Suspension

Honda: 2009 & Up Pilot

67590

Honda: 2005 & Up Odyssey



HONDA REAR CAMBER ARMS

67570
67590

These adjustable rear upper control arms, for the 2009 & up Honda Pilot, delivers 6° of camber change. The adjustable arm has OE style ball joint and bushing making it an ideal piece for both collision repair and traditional wheel alignment needs.

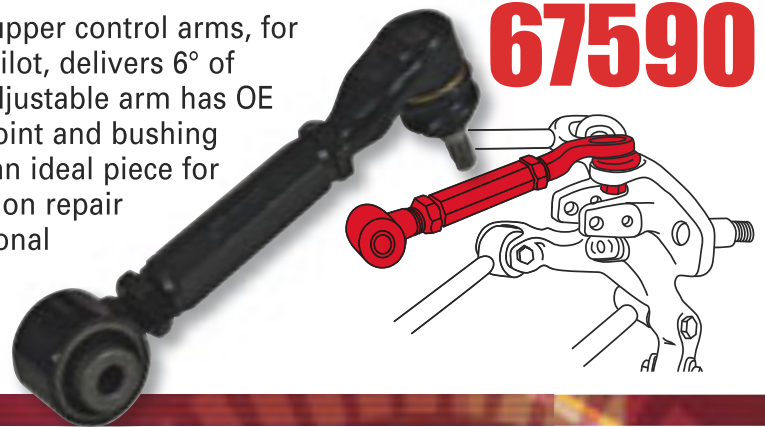

Rear Adjustment range:
Camber -2.00° to $+4.00^{\circ}$

Installation time: .5 hr/side

Required: 1 per wheel

APPLICATIONS

Honda: 2007 & Up CR-V

HONDA CR-V REAR ARM

67580

These arms fit popular CR-Vs. By removing the stock upper rear control arm and replacing it with the adjustable arm you can adjust camber either positive or negative with the turnbuckle adjuster. This arm can be used on vehicles with stock ride height or vehicles that have been altered for performance.

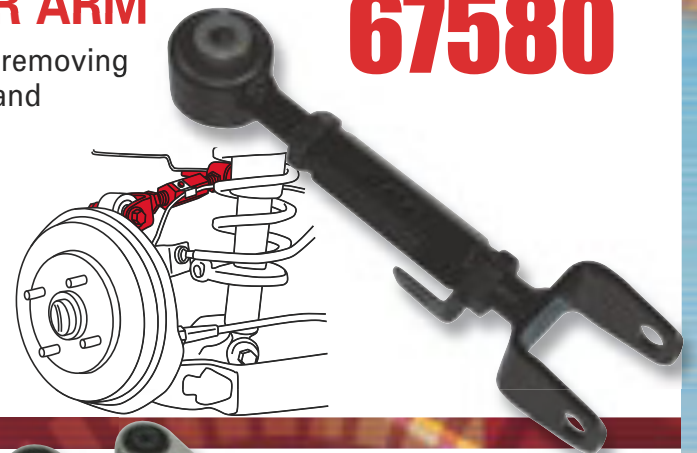

Rear Adjustment range:
Camber $\pm 4.00^{\circ}$

Installation time: .6 hr/side

Required: 1 per axle

APPLICATIONS

Mini Cooper: 2002 & Up Mini Cooper, Mini Cooper S
2011 & Up Countryman

MINI COOPER REAR CAMBER ARM (PR)

67610

These billet aluminum arms are a great camber solution for these tuner vehicles. In a beautiful silver anodized finish with SPC "Red" nuts, these arms give you a full $\pm 4.0^{\circ}$ of rear camber change.



Front Adjustment range:
Camber $\pm 2.00^{\circ}$ Caster $\pm 0.75^{\circ}$

Installation Time: 1.2 hr/side

Required: 1 kit per axle

APPLICATIONS

67620

Mini: 2002 - 06 Cooper, CooperS

67630

Mini: 2007 & Up Cooper, CooperS

MINI COOPER FRONT STRUT MOUNT (PR)

67620
67630

Crafted from aircraft quality aluminum, these precision machined adjusters feature OE style bearings and a bonded urethane insulator.

Tuners will find this kit, with its ability to change both camber and caster, perfect for both performance and racing applications.



72095 - Pg 129 - Use this tool for struts with adjustable damping

SPC PERFORMANCE



Rear Adjustment range:
Camber $\pm 1.5^{\circ}$ Toe $\pm 1.5^{\circ}$

Installation Time: .8 hr/side

Required: 1 per wheel

APPLICATIONS

Subaru: 1993 - 07 Impreza
1993 - 07 WRXs (**Excluding** STIs)
1990 - 99 Legacy, Outback, GT

Saab: 2005 - 07 9-2X

SUBARU/SAAB EZ ARM XR™ (PR)

67640

This set of 2 adjustable lower control arms will provide up to $\pm 1.5^{\circ}$ of additional camber and toe adjustment for all 1993 - 07 Imprezas and WRXs (except STIs) and Saab 9-2Xs. Especially designed for the performance enthusiast, these arms can be used on lowered or stock ride height vehicles.



Parts

67655

SUBARU/SCION ADJ. REAR TOE ARM

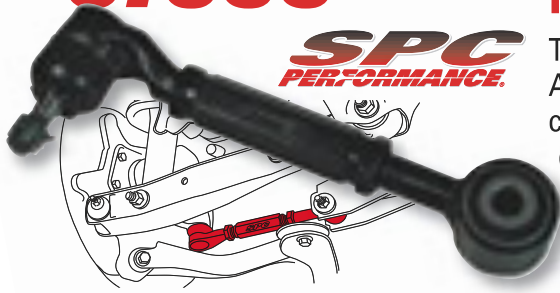

The Subaru Adjustable Rear Toe EZ Arm provides maximum toe change required due to camber changes. The toe arm incorporates an integrated OE style ball joint and is easily adjusted for positive or negative toe.

Rear Adjustment range: Toe $\pm 3.0^\circ$

Installation time: .5 hr/side

Required: 1 kit per wheel

APPLICATIONS

Scion: 2012 & Up FR-S

Subaru: 2008 - Up Forester, Impreza, STi, WRX 2012 & Up BRZ



67660

SUBARU/SCION ADJ. REAR CAMBER ARM AND TOE KIT

SPC PERFORMANCE

This hi-strength adjustable lower rear camber arm provides $\pm 2.0^\circ$ of change for the popular BRZ, FR-S, WRX and Impreza. Get the ultimate in performance and handling with this stamped arm featuring our new xAxis™ Sealed Joint which performs like a pillow joint but last like an OE joint. This kit is easy to adjust with a cam located at the outboard side of the arm. SPC's control arm is the only kit on the market to include an offset

toe bushing to increase the range of your factory cam. If you need more toe consider SPC's toe arm #67655.

Rear Adjustment range: Camber $\pm 2.0^\circ$ Toe 1.5° Fixed

Installation time: .5 hr/side

Required: 1 kit per wheel

APPLICATIONS

Scion: 2012 & Up FR-S

Subaru: 2008 - Up Forester, Impreza, STi, WRX 2012 & Up BRZ



NEW

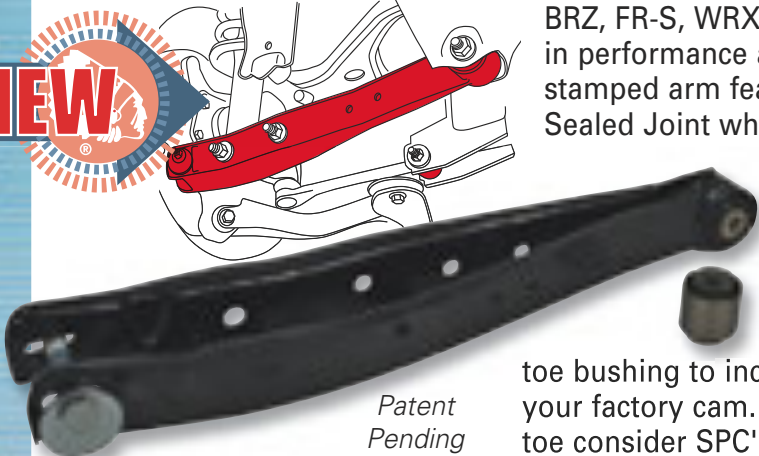

Patent Pending



67647 - Bushing Sleeves, pg 128

72509 - Ball Joint Press, pg 129

67720

NISSAN 240SX FRONT CASTER ROD (PR)



This replacement front adjustable strut rod is easily adjustable and gives these popular tuner vehicles the ability to change caster by 3° . A stiffer rubber bushing material provides better handling in performance applications.

Front Adjustment range: Caster $\pm 1.5^\circ$

Installation Time: .3 hr/side

Required: 1 kit per axle

APPLICATIONS

Nissan: 1989 - 98 240SX

67740

NISSAN 240SX TOE LINK (EA)



This adjustable arm increases the amount rear toe can be changed on this popular performance vehicle. It is recommended that this arm be installed when either the 67765 or the 67775/67776 (below) is being installed.

Rear Adjustment range: Toe $\pm 2.0^\circ$

Ins. Time: .3 hr/side

Req.: 1 kit per wheel

APPLICATIONS

Nissan: 1989 - 98 240SX



67765

NISSAN 240SX REAR CAMBER KITS

67775

67776



67765
L or R

These rear arms provide an increased amount of camber change on these popular tuner cars. Two arms are required per side and are adjusted together to give the maximum amount of camber change without affecting wheel setback. Stiffer rubber bushing material is used for better handling in performance applications.

67775 - Left
67776 - Right



Rear Adjustment range: Camber $\pm 3.0^\circ$ (2 Arm Set)

Installation time: 1.0 hr/side

Required: 1 kit per wheel

APPLICATIONS

67765 Left or Right

Nissan: 1989 - 94 240SX 1990-96 300ZX

67775 Left
67776 Right
Nissan: 1995 - 98 240SX



1-800-525-6505

Call for your nearest distributor, product info or Technical Assistance • In the USA and Canada

www.specprod.com



Rear Adjustment range: See Applications

Installation time: .3 hr/side

Required: 1 kit per axle



APPLICATIONS

69100* Honda: 1996 - 00 Civic

69200* Acura: 1990 - 01 Integra (Not Type R)
Honda: 1988 - 95 Civic; 1988 - 92 CRX
1992 - 97 Del Sol

**Note: These arms are shorter than the OEM arm. Camber will be affected and these arms must be used with 67030 adjustable rear upper arm (page 61)*

69300** Honda: 2001 - 05 Civic

69400** Acura: 2002 - 07 RSX
Honda: 2002 - 06 CR-V
2003 - 11 Element

***Note: These arms are for appearance and weight saving only. They include a special Socket, Part 69330 (page 128) which is required for installation.*

HONDA/ACURA REAR CLEARANCE ARMS (PAIR)

69100- 69400

These extreme lower control arms are for Honda Civics and Acura Integras and RSXs. Made from aircraft aluminum alloy, these arms are available in a silver finish.

When teamed up with front and rear camber arms SPC Performance provides you with a complete alignment solution when lowering your Civic, Del Sol, RSX, or Integra.

It is recommended that a toe adjuster (below) be used with these arms.

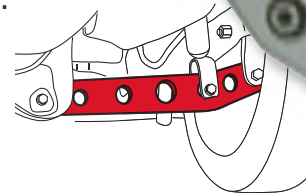

Rear Adjustment range: Toe $\pm 2.00^\circ$

Installation time: .6 hr/side

Required: 1 kit per axle

APPLICATIONS

Acura: 1996 - 00 EL; 1990 - 01 Integra

Honda: 1988 - 00 Civic; 1988 - 92 CRX
1992 - 97 Del Sol

HONDA/ACURA TOE ADJUSTER

69250

This kit allows for easier and more accurate toe adjustments. May be used alone, however a toe adjuster should be used with Clearance Arms (above).

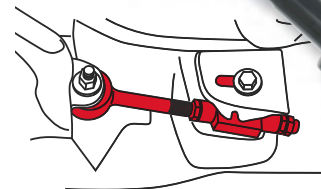

Rear Adjustment range: Toe $\pm 2.00^\circ$

Installation time: .5 hr/side

Required: 1 kit per axle



APPLICATIONS

69450 Acura: 1996 - 00 EL; 1990 - 01 Integra
Honda: 1992 - 00 Civic
1992 - 97 Del Sol

69460 Honda: 1988 - 91 Civic
1988 - 92 CRX

HONDA/ACURA TOE ADJUSTER

69450 69460

These great looking kits adjust toe with a polished aluminum red finish. May be used alone, however a toe adjuster should be used with Clearance Arms (above).

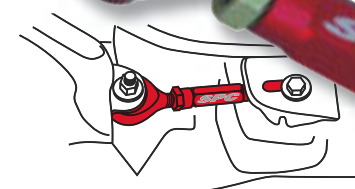

Rear Adjustment range:
Camber $\pm 1.00^\circ$ / Toe $\pm 1.00^\circ$

Installation time: .5 hr/side

Required: 1 shim per wheel/
per angle changed

APPLICATIONS

Toyota FWD: 1998 - 10 Sienna
Nissan FWD: 2011 & Up Leaf

FULL CONTACT REAR SHIMS

71020 SERIES

CAMBER/TOE Part No. Change

71020	.06°
71021	.13°
71022	.25°
71023	.38°
71024	.50°
71025	.75°

These full contact rear shims will correct camber and/or toe. Combination adjustments, or changes up to 1.0° may be achieved by using 2 shims on each wheel.

71000 SHIM SET - Includes 12 shims/2 each no.



NOTE:
Do NOT
adjust
Camber
or Toe
over 1.0°



Suneil Suravarapu (Sunny) has been building this Honda since 2004. His current project, a 2004 Accord coupe/six speed, has gone through three transformations. KWKEMRT (from the Simpson's) has been both a booth and feature car at SEMA. Featured in two magazines. Sunny has run SPC Performance Parts on his cars since he started tuning Hondas in 1999.

Parts

71030 71040 SERIES

71050 71060 SERIES

GM REAR TOE AND CAMBER SHIMS

Make rear wheel alignment changes on these twist beam axles with SPC's stackable fixed change shims. Change camber in $\pm.25^\circ$ increments and toe in $\pm.10^\circ$ increments. Combine a toe shim with a camber shim to get the exact change required. Stack up to two shims for maximum change.

71030
Toe
71040
Camber



TOE		Degree of Change
71030 Series	71050 Series	
71031	71051	$\pm.10^\circ$
71032	71052	$\pm.20^\circ$
71033	71053	$\pm.30^\circ$
71034	71054	$\pm.40^\circ$
71035	71055	$\pm.50^\circ$

CAMBER		Degree of Change
71040 Series	71060 Series	
71041	71061	$+.25^\circ$
71042	71062	$+.50^\circ$
71045	71065	$-.25^\circ$
71046	71066	$-.50^\circ$

Rear Adjustment range:
Camber $\pm 1.00^\circ$ /Toe $\pm 1.00^\circ$

Installation time: .5 hr/side

Required: 1 or 2 per wheel

APPLICATIONS

71030 (Toe) & 71040 (Camber)

Buick: 2012 & Up Verano
Cadillac: 2013 & Up ELR
Chevrolet: 2011 & Up Cruze
2001 & Up Volt

71050 (Toe) & 71060 (Camber)

Chevrolet: 2012 & Up Sonic
2012 & Up Aveo



Missing our Full Contact Nylon Shims? You can use our EZ Shim for all of our discontinued Shim applications, see page 78.

NEW

71050 Toe
71060 Camber



71520 71530 SERIES

VW/AUDI REAR SHIMS

With these shims you can correct rear camber and toe on newer Volkswagens and Audis. By combining the shims (two may be used on each wheel) you can get up to $\pm.50$ to ± 1.0 camber change and up to $\pm.50^\circ$ toe change. Our wrench (87530) is a must when installing these shims. It allows you to remove the brake tone ring, bearing, seal and hub assembly as one unit.

Rear Adjustment range:
Camber $\pm.50^\circ$ to $\pm 1.00^\circ$ /
Toe $\pm.13^\circ$ to $\pm.50^\circ$

Installation time: .5 hr/side

Required: 1 shim per wheel/
per angle changed

APPLICATIONS

Audi: 2000 - 06 TT
Volkswagen: 1999 - 10 Beetle
1999 - 06 Golf (Except R32)
1999 - 06 GTi
1999 - 05 Jetta (Beam Rear Axle)

CAUTION: Check brake & rotor clearance for binding. 75970 spacers (page 78) maybe required.

87530 - VW Shim Wrench, pg 134

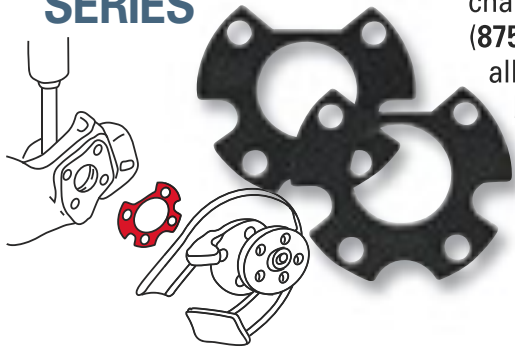

NOTE: When installing these shims we recommended that you use our VW Shim Wrench (#87530 pg. 134) to assist in removing the rear hub.

71500 SHIM SET - Includes 16 shims/2 of each size and 87530 wrench.

TOE		CAMBER	
Part No.	Change	Part No.	Change
71520	$\pm.13^\circ$	71530	$+.50^\circ$
71521	$\pm.25^\circ$	71531	$+1.00^\circ$
71522	$\pm.38^\circ$	71532	$-.50^\circ$
71523	$\pm.50^\circ$	71533	-1.00°



87530 - Wrench

71720 71730 SERIES

CHRYSLER MINI-VAN SHIMS

For camber and toe change, use our Mini-Van Shims that allow for quick and easy changes in increments of: toe $.10^\circ$ and camber $.25^\circ$.

Rear Adjustment range:
Camber $\pm 1.00^\circ$ /Toe $\pm.10^\circ$ to $\pm.80^\circ$

Installation time: .5 hr/side

Required: 1 shim per wheel/
per angle changed

APPLICATIONS

Chrysler 2001 & Up Town & Country
FWD: 1996 - 00 Town & Country
w/o ABS
2000 - 03 Voyager
Dodge 2001 & Up Caravan
FWD: 1996 - 00 Caravan
w/o ABS
Nissan: 2007 -12 Sentra w/o ABS
Plymouth 1996 - 01 Voyager
FWD: w/o ABS



71700 SHIM SET - Includes 20 shims/2 of each size.

TOE		CAMBER	
Part No.	Degree of Change	Part No.	Degree of Change
71720	$\pm.10^\circ$ [.05" (1/16")]	71723	$\pm.40^\circ$ [.20" (3/16")]
71721	$\pm.20^\circ$ [.10" (1/8")]	71724	$\pm.50^\circ$ [.25" (1/4")]
71722	$\pm.30^\circ$ [.15" (5/32")]	71725	$\pm.80^\circ$ [.40" (3/8")]
		71730	$\pm.25^\circ$ (1/4")
		71731	$\pm.50^\circ$ (1/2")
		71732	$\pm.75^\circ$ (3/4")
		71733	$\pm 1.00^\circ$ (1")



Front Adjustment range:
Camber $\pm 2.00^\circ$ Caster $\pm 2.00^\circ$

Installation time: 1.0 hr/side

Required: 1 kit per axle

APPLICATIONS

Ford: 2005 - 11 Mustang

Note: We do not recommend the use of caster/ camber plates on coil-over



equipped vehicles.

MUSTANG FRONT CAMBER/CASTER STRUT MOUNT

In 2005 Ford introduced the new Mustang. SPC's adjustable strut mount will give you an additional 4° of camber or caster on these newer vehicles. By replacing the existing upper strut mount and utilizing the stock strut bearing and spring plate, you will maintain factory ride and get maximum adjustment.

Note: Modification of the strut tower opening will be necessary to gain access to adjusting bolts.



Rear Adjustment range:
Tracking $\pm 1.5"$

Installation time: 0.5 hr/side

Required: 1 per axle

APPLICATIONS

Ford: 2005 & Up Mustang



MUSTANG ADJUSTABLE PANHARD BAR

SPC aluminum panhard bars provide weight savings and adjustability! Manufactured from aircraft grade aluminum, precision TIG welded, and then black anodized, the SPC panhard bar is the lightest durable unit on the market. High durometer vulcanized rubber bushings promote precise handling while maintaining factory noise levels and damping qualities. SPC's bushings are the same size as factory bushings and lend themselves to other aftermarket bushings if stiffer bushings or different materials are required. Adjust your Mustang SPC panhard bar on the car to optimize lateral stability and tracking.

72045

Arm Length
36 inches

Complete your suspension tuning project plus get additional pinion and thrust angle adjustments by using SPC's adjustable trailing arms #72345 (page 77)



72050

Rear Adjustment range:
Camber $\pm 3.00^\circ$ Toe $\pm 2.00^\circ$

Installation time: .7 hr/side

Required: 1 kit per wheel

72050 & 72055 APPLICATIONS

Infiniti: 2003 - 07 G35 Coupe
2003 - 06 G35 Sedan

Nissan: 2003 - 08 350Z
2002 - 06 Altima

NISSAN/INFINITI EXTREME REAR CAMBER/TOE KIT

This is the perfect kit for the lowered Z or G35. Provides additional camber and comes with a larger offset toe cam to bring the toe angle back into range. Use the **85130** rotary file set to elongate the toe slots.

72050

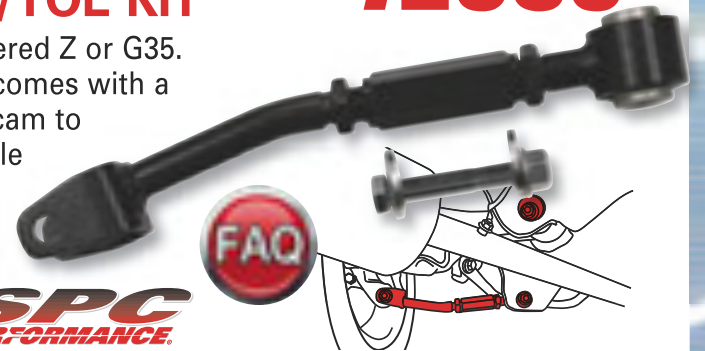

72055 Only

Nissan: 2007 & Up Altima

72055

Rear Adjustment range:
Camber $\pm 2.00^\circ$ Toe $\pm 2.00^\circ$

Installation time: .6 hr/side

Required: 1 kit per wheel



85130 - Rotary File, pg 133

NISSAN/INFINITI REAR CAMBER/TOE KIT

These cams (set of 2) replace the OE camber and toe adjustment cams and provide additional camber and toe changes. Adjustment slots will need to be elongated using **85130** rotary file set or equivalent.

72055

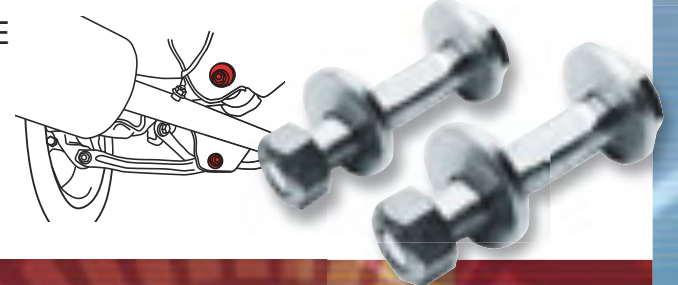

Front Adjustment range:
Camber -0.50° to $+1.50^\circ$
Caster 0.0° to $+1.50^\circ$

Installation time: 1.0 hr/side

Required: 1 kit per axle

APPLICATIONS

Ford: 1994 - 04 Mustang

Note: We do not recommend the use of caster/ camber plates on coil-over equipped vehicles.

MUSTANG FRONT CAMBER/CASTER STRUT MOUNT

These adjustable strut mounts feature polyurethane bushings for quiet operation and maximum performance, and are CNC machined from 6061 heat treated aluminum. The TIG welded strut hats increase strut travel which is especially important on lowered cars. These plates also come complete with special strut boots and bump stops.

72060



Parts

72065
72070
72080
72090



BMW FRONT ADJUSTABLE UPPER STRUT MOUNTS

Engineered utilizing a unique, multi-adjustable design, these strut mounts fit a wide variety of BMWs.

Crafted from aircraft quality aluminum, these precision machined adjusters feature OE style bearings and a bonded urethane insulator.

Tuners will find this kit's ability to change both camber and caster, perfect for both performance and racing applications.

Not recommended for aftermarket coil-over equipped vehicles.

Front Adjustment range:
Camber -1.00° to +3.00° Caster ±.50°

Installation time: 1.2 hr/side Req: 1 kit per axle

APPLICATIONS

72065 BMW AWD: 1984 - 91 3 Series (E30)

72070 BMW 2008 - 11 1 Series (E81, E82, E87, E88)
AWD: 2007 - 12 3 Series (E90, E91, E93, E93)
2006 - 12 3 Series Sedan/Wagon (E90, E91)

BMW 1992 - 99 3 Series 318, 325, 328, M3 (E36)
RWD: 1996 - 02 3 Series Z3 Coupe/Rdstr (E36)

72080 BMW 2000 - 04 3 Series Coupe/Conv. (E46)
RWD/AWD: 1993 - 03 3 Series Sedan/Wagon (E46)

BMW 1996 - 03 5 Series 525i, 528i w/o EDC, 528iT, 530i (E39)
RWD:

72090 BMW 2005 - 06 3 Series Sedan/Wagon (E46)
RWD/AWD: 2005 - 06 3 Series Coupe/Conv. (E46)

BMW 2003 - 08 3 Series Z4 (E85)
RWD: 1992 - 99 3 Series 318Ti (E30)

72095 - Pg 129 - Use this tool for struts with adjustable damping



See next page for additional adjustable front strut mounts for RWD 1 & 3 Series and more

72110

SPC PERFORMANCE

BMW REAR LOWER CONTROL ARM

These billet aluminum arms fit the 3-Series (E36/E46/E85) along with the new Z4, giving you -1.0° to +3.0° of rear camber change. Great for these popular tuner vehicles, these machined parts are in a stand-out silver anodized finished with SPC "Red" nuts. Our standard EZ Arm (#67110) for BMWs is shown on page 62.

Rear Adjustment range:
Camber -1.00° to +3.00°

Installation time: 1.3 hr/side

Required: 1 kit per axle

APPLICATIONS

BMW: 2000 - 06 3 Series Coupe and Convertible (E46)
1999 - 05 3 Series Sedan and Wagon (E46)
1992 - 99 3 Series 318, 323 and M3 (E36)
2003 - 08 3 Series Z4 (E85)

72125

SPC PERFORMANCE

350Z & G35 FRONT UPPER CONTROL ARMS (PAIR)

SPC Performance's arm/shim kit is the only one on the market to provide a substantial amount of positive camber change. It has more than enough camber and caster change to correct cars that have been lowered, or for vehicles used in drifting. These new arms allow for precise changes when fine tuning suspension alignment angles necessary when racing or drifting. The hub and caliper shims extend out the center of the wheel making it possible for our CNC fabricated arm to make up to 5° total camber change and ± 1° of caster change. Using a sliding and rotating ball joint, techs can fine tune both camber and caster to save tires and improve handling and tire to surface contact. The kit includes everything you need, including the ABS sensor bracket, shims, and arms for both sides of the vehicle.

Front Adjustment range:
Camber -1.5° to +3.5°
Caster ±1.0°

Installation Time: 1.8 hr/side

Required: 1 kit per axle

APPLICATIONS

Infiniti: 2003 - 07 G35 Coupe (with and w/o active steer)
2003 - 06 G35 Sedan
Nissan: 2003 - 08 350Z

8370 - Puller, pg 123



Patent No. US 7,513,514 B



These arms feature our Jounce Spacers for a quieter, OEM style ride

Front Adjustment range:
Camber $\pm 2.5^\circ$ Caster $\pm 1.0^\circ$

Installation Time: .6 hr/side

Required: 1 kit per axle

APPLICATIONS

Infiniti: 2008 - 12 EX35
2011 & Up G25 Sedan
2007 - 08 G35/G35X
Sedan (inc. active steer)
2009 & Up G37/G37X
Conv., Sedan
2008 & Up
G37 Coupe
(inc. active
steer)
Nissan: 2009
& Up 370Z



370Z & G37 FRONT UPPER CONTROL ARMS (PAIR)

This pair of front upper control arms will give you $\pm 1^\circ$ caster and $\pm 2.5^\circ$ camber change. Simply replace the OE front upper control arms and dial in your suspension angles with our patented sliding ball joint and caster plate. Whether you want to tune your suspension for the ultimate in handling performance, minimize tire wear or easily move back and forth between two settings, these are the arms to get the job done.

Patent No. US 7,513,514 B



These arms feature our Jounce Spacers for a quieter, OEM style ride

Front Adjustment range:
Camber -1.00° to $+3.00^\circ$
Caster $\pm .50^\circ$

Installation time: 1.2 hr/side

Required 1 kit per axle

APPLICATIONS

72180 BMW RWD:
1996 - 04 5 Series
528i w/EDC, 540i, 540iT, M5 (E39)

72190 BMW RWD:
2008 - 11 1 Series
(E81, E82, E87, E88)
2007 - 12 3 Series Coupe/Conv.
(E92, E93)
2006 - 12 3 Series Sedan/Wagon
(E90, E91)
2006 - 09 5 Series (E60, E61)

See previous page for additional adjustable front strut mounts for AWD 1 & 3 Series and more

BMW FRONT ADJUSTABLE UPPER STRUT MOUNTS

The 72180 and 72190 BMW fully adjustable upper strut mounts allow full camber adjustments from -1° to $+3^\circ$ and caster adjustments from $\pm .5^\circ$. Full adjustment for daily drivers to high performance racing angles is quickly and easily accomplished. Precision machining and components equals precision handling.

 **72095 - Pg 129 - Use this tool for struts with adjustable damping**

SPC PERFORMANCE

72180

**72180
72190**

72190



Rear Adjustment range:
Camber $\pm 1.25^\circ$ Toe $\pm 1.25^\circ$

Installation Time: .6 hr/side

Required: 1 per wheel

APPLICATIONS

BMW RWD: 1996 - 04 5 Series
528 w/EDC, 540i, 540iT, M5 (E39)
1996 - 03 5 Series
525i, 528 w/o EDC, 528iT, 530i,
(E39)
1996 - 03 6 Series - M6 (E63)

BMW 5/6 SERIES ADJ. REAR BUSHINGS

These rear control arm bushings provide an additional $\pm 1.25^\circ$ of camber and toe adjustment for the rear of the BMW 5 series. Replace the inboard bushings on the rear upper control arms with these innovative adjustable bushings for lifetime adjustability. Use standard bushing press sleeves and bushing press tool **72509** to remove the old bushings and press in the new ones.

 **72509 - Ball Joint Press, pg 129**

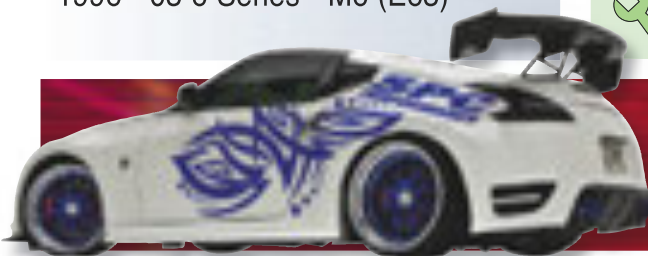

SPC is the choice of many top tuners and performance builders. An SPC SEMA feature car, Mike Mixon's 370Z, is still turning heads and showing them how it is done.

Parts

72260 72280

NISSAN/INFINITI EXTREME REAR CAMBER/TOE KIT



This is the perfect kit for lowered Zs or G35s and G37s Infinitis. Provides additional camber and comes with a larger offset toe cam to bring the toe angle back into range. Use the **85130** rotary file to elongate the toe slots.

See page 73 for additional rear arms for Nissans and Infinitis

SPC
PERFORMANCE



Rear Adjustment range:
Camber $\pm 3.00^\circ$ Toe $\pm 2.00^\circ$

Installation time: .7 hr/side

Required: 1 kit per wheel

APPLICATIONS

72260

Infiniti: 2006 - 07 G35 Coupe w/rear active steer
2007 - 08 G35/35x Sedan Incl. active steer

Nissan: 2009 & Up 370 Z

72280

Infiniti: 2008 & Up G37 Coupe incl. active steer
2009 & Up G37 Sedan
2009 & Up M35/45



85130 - Rotary File Set, pg 133

72265

NISSAN/INFINITI REAR CAMBER/ TOE KIT

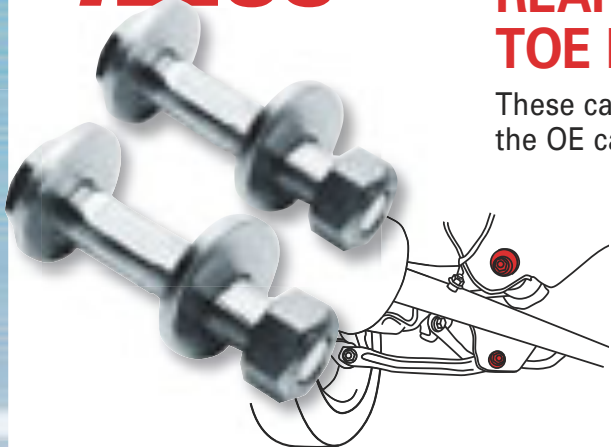

These cams (set of 2) replace the OE camber and toe adjustment cams and provide additional camber & toe changes. Adjustment slots will need to be elongated using **85130** rotary file or equivalent.

Rear Adjustment range:
Camber $\pm 2.00^\circ$ Toe $\pm 2.00^\circ$

Installation time: .6 hr/side

Required: 1 kit per wheel

APPLICATIONS

Infiniti: 2008 & Up G37 Coupe incl. active steer
2009 & Up G37 Sedan; 2009 & Up M35/45
2006 - 07 G35 Coupe w/rear active steer
2007 - 08 G35/35x Sedan Incl. active steer

Nissan: 2009 & Up 370 Z



85130 - Rotary File Set, pg 133

72270

LEXUS GS ADJUSTABLE FRONT ARMS (PR)



Patent No. US 7,513,514 B

This pair of Lexus upper control arms will give you $\pm 1^\circ$ caster and $\pm 2.0^\circ$ camber change. Simply replace the OE front upper control arms and dial in your suspension angles with our patented sliding ball joint and caster plate.

Whether you want to tune your suspension for the ultimate in handling performance, minimize tire wear or easily move back and forth between two settings, these are the arms to get the job done.

Front Adjustment range:
Camber $\pm 2.0^\circ$ Caster $\pm 1.0^\circ$

Installation Time: .6 hr/side

Required: 1 per axle

APPLICATIONS

Lexus:
1993 - 05 GS



SPC
PERFORMANCE

72290

NISSAN ALTIMA ADJ. REAR CONTROL ARM

NEW

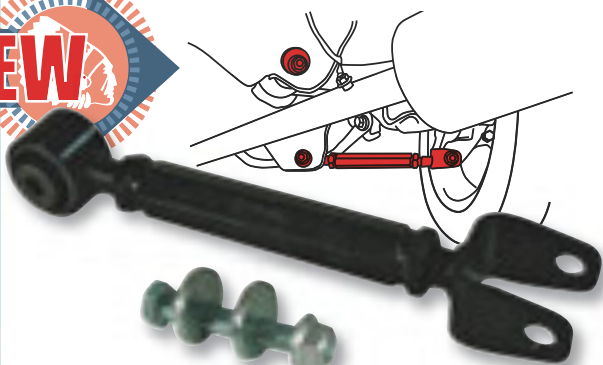

These arms fit the popular Nissan Altima. Simply replace the OE fixed length lower rear control arm with this adjustable arm to achieve $\pm 3^\circ$ of camber change. Use the included toe cam bolt to get up to $\pm 2^\circ$ of toe change. The arm and cam kit can be used for vehicles with stock ride height or lowered for performance.

Front Adjustment range:
Camber $\pm 3.0^\circ$ Toe $\pm 2.0^\circ$

Installation Time: .6 hr/side

Required: 1 per wheel

APPLICATIONS

Nissan: 2007 & Up Altima

1-800-525-6505

Call for your nearest distributor, product info or Technical Assistance • In the USA and Canada

www.specprod.com



Rear Adjustment range:
Pinion $\pm 4.0^\circ$ Add'l Thrust

Installation Time: .6 hr/axle

Required: 1 per axle

APPLICATIONS

Ford: 2005 & Up
Mustang

SPC
PERFORMANCE



MUSTANG REAR ADJUSTABLE TRAILING ARMS (PR)

These Adjustable Rear Trailing Arms for 2005 and up Ford Mustang offer you the ability to adjust thrust, tracking, and pinion angle to optimal specs for your driving style or track conditions. Made of 6061 aluminum, these light weight, high strength arms look great with a black anodized finish.



Check out SPC's adjustable panhard bar #72045 and adjustable front strut mounts #72040 on page 73.

Front Adjustment range:

72350 Camber $\pm 1.50^\circ$
Caster $\pm .50^\circ$

Installation Time: 1.0 hr/axle

Required: 1 per axle

72355 Caster $\pm .50^\circ$

Installation Time: .4 hr/wheel

Required: 1 per wheel

APPLICATIONS

Ford: 2005 & Up Mustang



85130 - Rotary File Set,
pg 133

MUSTANG FRONT ALIGNMENT KITS

72350 Kit bundles a pair of EZ Cams (p/n 81260) for adjusting camber $\pm 1.5^\circ$, with two **72355** Caster Bolts (below). Together these parts overcome the non-adjustable factory design to provide complete adjustability for improved handling, reduced tire wear, and better drivability.

72355 Cam bolt kit provides caster adjustment by replacing one of the two factory bolts that mount the rear control arm bushing bracket. Elongation of the pre-marked factory holes is required - we recommend using rotary file set 85130 or similar. Includes one smaller cam.

72350
72355

#72355 Includes only
One Caster Cam



Patent
Pending

Rear Adjustment range:
Camber $+ .25^\circ$ to $+ .75^\circ$

Installation time: .3 hr/side

Required: 1 kit per axle

APPLICATIONS

Chrysler: 1995 - 00 Sebring
2001 - 06 Sebring 2Dr Coupe
Dodge: 1995 - 00 Avenger
Eagle: 1995 - 98 Talon RWD/4WD
Mitsubishi: 1997 - 04 Diamante
1995 - 05 Eclipse RWD/4WD
1994 - 03 Galant



73415

CHRYSLER/MITSUBISHI REAR SHIM PACK

For positive camber change use our **73400** Rear Shims (6 per pack) that allow for quick and easy camber changes in increments of $.25^\circ$ up to $.75^\circ$. Each shim changes camber by $.25^\circ$, the entire pack equals $.75^\circ$ change if all shims are used.

73415 BOLT SET - Set of 4 bolts.

NOTE: Changes in camber greater than $.75^\circ$ require an additional shim kit and the installation of longer bolts. Use these bolts - Specialty Part 73415.

73400
SHIM PACK



Rear Adj. range: Camber

73600 $-.75^\circ$ to $+1.50^\circ$

73620 $-.75^\circ$ to $+3.00^\circ$

Installation Time: .5 hr/side

Required: 1 kit per wheel

APPLICATIONS

Chrysler: 1995 - 00 Sebring
2001 - 06 Sebring 2Dr Coupe
Dodge: 1995 - 00 Avenger
Eagle: 1995 - 98 Talon RWD/4WD
Mitsubishi: 1997 - 04 Diamante
1995 - 05 Eclipse RWD/4WD
1994 - 03 Galant

CHRYSLER/MITSUBISHI REAR CAMBER BOLT AND BRACKET

This bolt and bracket set allows for greater rear camber change on 1995 and up Sebrings, Avengers, Talons and Eclipses. One kit covers one side of the vehicle.

PART NO. 73600

(No Spacers)

PART NO. 73620

(With Spacers & Bolts)



73600
73620

Parts

75200 BLUE

75400 GREY

75600 YELLOW

75800 RED

EZ Shim™

FULL CONTACT DUAL ANGLE

A patented Full Contact Dual Angle shim, consisting of only four part numbers, that corrects Toe and Camber with one shim.

These two-piece adjustable shims are available in 4 sizes which cover many rear shimable FWD vehicles. Durable construction, proven adjustment changes within .03° toe and .10° camber

CAUTION: Check for caliper to rotor clearance when installing this part on vehicles equipped with rear disc brakes. Some vehicles may require the use of longer bolts.

Recommend use of 10408 bolts (page 49) and 75970 spacers (below) as required



75915 - EZ Shim Cutter (below)

ACCESSORIES

75910 DIAL CHART

75910
EZ Shim™ dial Chart lists changes in decimal degrees only.

Makes using the EZ Shim a snap. Just dial in the desired change needed for both camber and toe.

75915 CUTTER

This cutter is a necessary tool for cutting the EZ Shim™ Its thin cutting blades minimize shim breakage.

75920 MARKER

This will mark the areas to be removed. Marks will not rub off, and are easy to see.

75970 SPACER SET (8)

This set (4 different sizes - 2 of each) aligns caliper to rotor after installation of a camber shim. Specifically designed to be used with the EZ Shim when correcting some FWD cars with hub mounted rear disc brakes.



EZ SHIM™ ONLINE

Get up to date templates and applications online with our EZ Shim Online program. Easy to follow shim selection for the EZ Shim with instructions and videos to help you install your shim. Go to <http://spcalignment.com/ezshim/>



80199-81099

Truck Axle Shims

ZINC CASTER/PINION SHIMS

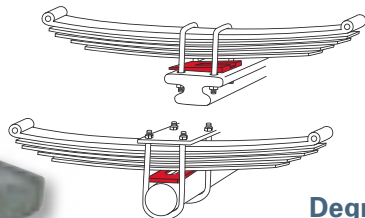

These heavy-duty axle caster shims can also be used to adjust pinion angle on Jeep CJs and similar vehicles with 1-3/4" to 2" wide leaf springs. **Six shims per box.**

No.	Width	Degree Taper	Qty	No.	Width	Degree Taper	Qty
80199	1-3/4 to 2"	1/2°	6	80699	1-3/4 to 2"	3°	6
80299	1-3/4 to 2"	1°	6	80799	1-3/4 to 2"	3-1/2°	6
80399	1-3/4 to 2"	1-1/2°	6	80899	1-3/4 to 2"	4°	6
80499	1-3/4 to 2"	2°	6	80999	1-3/4 to 2"	5°	6
80599	1-3/4 to 2"	2-1/2°	6	81099	1-3/4 to 2"	6°	6

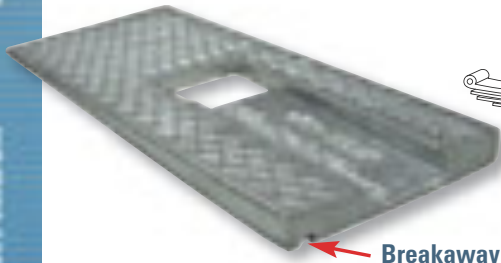

For additional shim widths see page 90

Do you specialize in Heavy Duty Trucks or maintain a truck fleet?

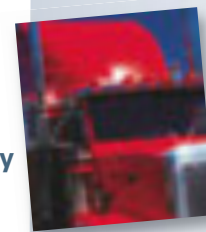

Check out our complete Heavy Duty Truck

Section on pages 101-111.

Applications
Parts
Heavy Duty
Racing/Off Road
Tools
Accessories
Brake & CV
Gear/Index



81240, 81250, 81260, 81270, 81280, 81290

EZ Cam™ XR

Front Adjustment range:
Camber $\pm 1.75^\circ$

Installation time: .4 hr/side

Required: 1 kit per axle

APPLICATIONS

See application charts,
pages 7-45 for years.

81240 pr (10mm)

Alfa Romeo, Fiat, Lancia

81250 pr (12mm)

Chevrolet, Cadillac, Daihatsu, Daewoo,
Dodge, Eagle, Ford, Geo, Hyundai,
Infiniti, Isuzu, Mazda, Mercury,
Mitsubishi, Nissan, Plymouth, Pontiac,
Porsche, Renault, Saab, Saturn,
Suzuki, Toyota, Volkswagen, Volvo

81260 pr (14mm)

Acura, Buick, Chevrolet, Chrysler,
Daewoo, Dodge, Honda, Hyundai,
Infinity, Mitsubishi, Nissan, Plymouth,
Saturn, Subaru, Toyota, Volvo

81270 pr (15mm)

Geo, Lexus, Toyota

81280 pr (16mm)

Acura, Buick, Cadillac, Chevrolet,
Chrysler, Dodge, Eagle, Ford, Honda,
Hyundai, Kia, Lincoln, Mercury,
Oldsmobile, Pontiac

81290 pr (17mm)

Lexus, Toyota

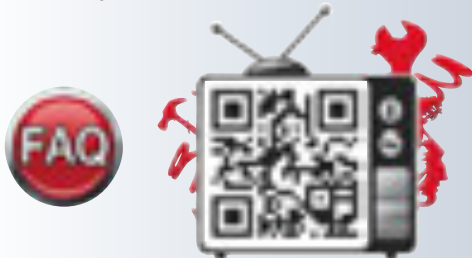

FOR DOMESTIC/IMPORT TWO BOLT STRUTS

EZ Cams™ make non-adjustable two bolt struts adjustable up to $\pm 1.75^\circ$ camber change. Head markings show where the cam is for maximum change and an easy-to-manipulate toothed washer lets you set positive or negative change. Simply remove the upper OE bolt, loosen the lower bolt, install and adjust the EZ Cam to the desired change and then tighten everything to specification. This is an easy fix for camber issues and a perfect companion sale for any strut job. Save time, money and effort by making aligning two bolt struts a one man job without grinding. Keep one of each part number in stock, measure the OE threads, replace the OE bolt with SPC's EZ Cams to make your alignment jobs fast and profitable.

Part No. 81240 (pr)
For replacement of 10mm bolts

Part No. 81250 (pr)
For replacement of 12mm bolts

Part No. 81260 (pr)
For replacement of 14mm bolts

Part No. 81270 (pr)
For replacement of 15mm bolts

Part No. 81280 (pr)
For replacement of 16mm bolts

This kit may also be used on GM vehicles equipped with aftermarket slotted struts with the addition of our adapter plate, 81286 included with cams.

Part No. 81290 (pr)
For replacement of 17mm bolts



Patent Pending

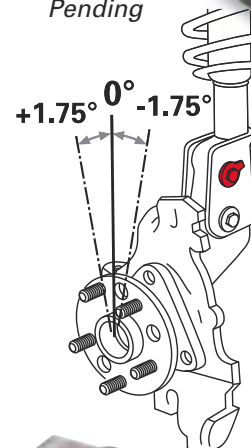

NO Special Tools
NO Grinding Necessary



Its easy to check camber change before, during and after EZ Cam installation with our 83119 Magnetic Adjustable Camber Gauge (page 132)

Constantly evolving.

Our EZ Cam™ XRs have a new look. This change is a significant upgrade in corrosion protection versus our previous EZ Cam and competitive products. The installer will notice that the new finish looks like the finish on the fastener that he is replacing.

SPC made this change for three reasons:

1. Increase corrosion resistance from ≈ 20 hour SST (Salt Spray Test) to ≈ 700 hour SST
2. Eliminate any potential for hydrogen embrittlement introduced by the zinc plating process
3. Meet Specialty Products' expectations for environmental stewardship – this is a water based and hex chromate free finish which is significantly better for the environment



Parts

81305

SCION/SUBARU CAM BOLTS

By installing these cam bolts in the **lower bolt position** on the 2 bolt front strut assembly of this popular platform you can dial in front camber adjustments.

Patent Pending

Front Adjustment range:

Camber $\pm 1.75^\circ$

Installation time: .4 hr/side

Required: 1 kit per axle

APPLICATIONS

Scion: 2012 & Up FR-S

Subaru: 2012 & BRZ

NEW

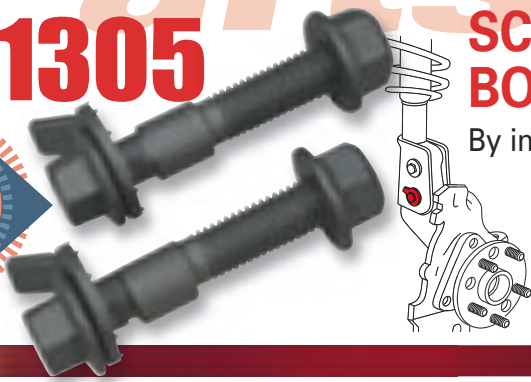

81310

FORD FOCUS REAR CAMBER KIT (PAIR)

This kit replaces the outer bolt of the upper rear control arm and provides plus or minus 1° of camber adjustment. Perfect for lowered vehicles or standard alignments.

Patent Pending

Rear Adjustment range:

Camber $\pm 1.0^\circ$

Installation time: .5 hr/side

Required: 1 kit per axle

APPLICATIONS

Ford: 2000 & Up Focus

Volvo: 2008 & Up C30
2004 - 12 S40, V50

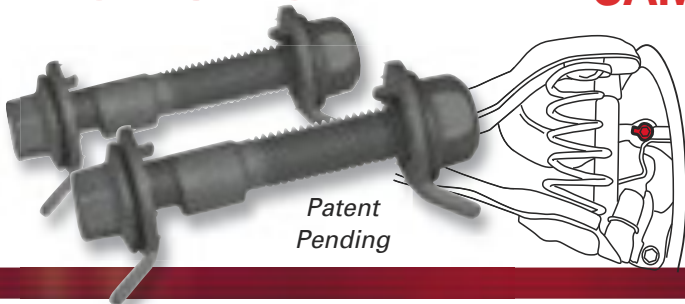

81320

FORD FOCUS FRONT CAMBER/CASTER KIT

Now you can adjust the front camber and caster on the Ford Focus with this upper strut plate. To install, remove the strut assembly, compress the spring and replace the O.E. upper bearing plate with the **81320**.

SPC PERFORMANCE.

Ford: 2000 - 10 Focus

Front Adjustment range:

Camber $\pm 1.00^\circ$ /Caster $\pm 1.00^\circ$

Installation time: 1.0 hr/side

Required: 1 kit per wheel

APPLICATIONS



81340

VW/AUDI FRONT CAMBER/CASTER KIT

Adjust both camber and caster with this new kit on current model Volkswagens and Audis. Simply remove the strut assembly, compress the spring and replace the O.E. upper bearing plate with this adjustable plate assembly.

SPC PERFORMANCE.

Front Adjustment range:

Camber $\pm 1.00^\circ$ /Caster $\pm 1.00^\circ$

Installation time: .9 hr/side

Required: 1 kit per wheel

APPLICATIONS

Audi: 2000 - 06 TT FWD/AWD

Volkswagen: 1999 - 10 Beetle

1999 - 06 Golf, GTi (A4)

2004 - 06 Golf R32, 1999 - 05 Jetta (A4)

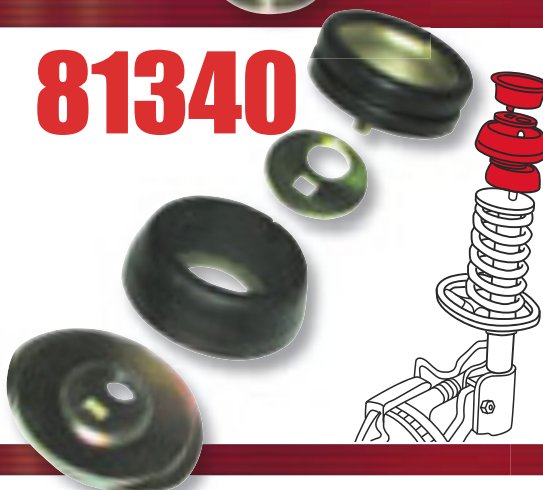

81350 81360

AUDI AND VW FRONT UPPER MULTI LINK ARM SET

This set of adjustable upper control arms will allow $\pm 1.5^\circ$ camber and/or caster change on a wide range of Audi and VW models. These arms directly replace factory fixed-length arms, allowing easy adjustments after installation.

Engineered for both street and track use,

forged 6061-T6 aluminum ends with large 18mm threaded adjuster links assure this is the strongest kit available.

Maintenance free ball joints and bushings provide factory ride, handling, and NVH performance.

Front Adjustment range:

Camber $\pm 1.50^\circ$ Caster $\pm 1.50^\circ$

Installation time: .7 hr/side

Required: 1 kit per wheel

81350 APPLICATIONS

Audi: 1998 - 08 A4

1990 - 01 A4 Quattro

2007 - 08 A5/S5

1998 - 04 A6/Quattro/RS6

2000 - 08 RS4, S4

Volkswagen: 1998 - 05 Passat
w/ beam type rear axle

81360

APPLICATIONS

Audi: 2009 & Up A4, RS4, S4

2009 & Up A5, S5

2010 & Up A7, S7

2009 & Up Q5

2013 & Up SQ5



SPC PERFORMANCE.

1-800-525-6505

Call for your nearest distributor, product info or Technical Assistance • In the USA and Canada

www.specprod.com



Front Adjustment range: Camber $\pm 2.50^\circ$

Installation time: .4 hr/side Req.: 1 kit per axle

APPLICATIONS

See application charts, pages 7-45 for years.

Buick: Century, Skylark

Chevrolet: Celebrity, Citation, Lumina AP

Oldsmobile: Ciera, Custom Cruiser FWD, Cutlass Cruiser, Omega, Silhouette APV

Pontiac: Phoenix, Transport APV, 6000, and rear of Pontiac Fiero

GM CAMBER KIT (PAIR)

82110

This cam bolt kit changes camber up to $2\frac{1}{2}^\circ$ positive or negative.



Front Adjustment range: Camber $\pm 2.50^\circ$

Installation time: .6 hr/side Req.: 1 kit per axle

APPLICATIONS

See application charts, pages 7-45 for years.

Buick: Electra, Le Sabre, Park Avenue, Reatta, Regal, 95 Riviera, Skyhawk, Somerset **Cadillac:** Allante, Cimarron, Deville, Eldorado, Fleetwood, Seville, STS **Chevrolet:** Beretta, Camaro, Cavalier, Corsica, Lumina Sedan, Monte Carlo **Chrysler:** Concord, LHS, New Yorker **Dodge:** Intrepid, Monaco **Eagle:** Medallion, Premier, Vision **Ford/Lincoln/Mercury:** Cars with modified strut suspensions **Lexus:** ES250, ES300 **Oldsmobile:** Achieva, Aurora, Calais, Cutlass Supreme, Delta 88, Firenza, 98 Regency, Toronado, Trofeo **Pontiac:** Bonneville, Firebird, Grand Am, Grand Prix, J2000, Sunbird, Sunfire **Toyota:** Avalon, Camry, Previa

CAMBER KIT (PR)

82120

This cam bolt kit changes camber up to $\pm 2.5^\circ$. It includes an adjusting plate to make the camber adjustment possible. After elongating the lower strut/spindle bolt hole with a rotary file, install the **82120** bolt and plate, rotating the bolt head to the desired adjustment.

 **85125 - Rotary File Set, pg 133**



Front Adjustment range: Camber $\pm 1.50^\circ$ Caster $\pm 1.50^\circ$

Installation time: .5 hr/side

Required: 1 kit per wheel

APPLICATIONS

Dodge: 2011 & Up Durango

Jeep: 2011 & Up Grand Cherokee



DODGE/JEEP FRONT CAM./CAS. ADJUSTING KIT

82360

Install this cam and guide kit to quickly and accurately dial in the alignment angles on 2011 and newer Grand Cherokees and Dodge Durangos. Even with the suspension loaded, this kit makes changes of up to $\pm 1.5^\circ$ camber/caster fast and easy.



Rear Adjustment range: Pinion Angle $\pm 2.00^\circ$

Installation time: .3 hr/axle

Required: 1 kit per axle

APPLICATIONS

Jeep: 1993 - 98 Grand Cherokee 1997 - 06 Wrangler (TJ)

JEEP REAR PINION ANGLE ADJUSTING BOLTS

82370

Correct rear pinion angle on Jeep TJs & ZJs by replacing the OEM bolts on the upper trailing arms with these cam bolts (p/n 82370). Rotate to make adjustments.

 **64225 - Angle Gauge, pg 127**



Front Adjustment range: Caster $\pm 1.50^\circ$ /Pinion Angle $\pm 1.50^\circ$

Installation time: .4 hr/axle

Required: 1 kit per axle

82380 APPLICATIONS

Jeep 4WD: 1997 - 06 Wrangler (TJ)

Dodge 4WD: *With 36mm cams*
1994 - 01 1500 Ram
1994 - 99 2500 Ram
w/LD Dana 44 Fr. Axle

82390 APPLICATIONS

Jeep RWD/4WD: 2007 & Up Wrangler (JK)

JEEP CASTER/PINION ANGLE ADJUSTERS

82380 82390

These cams replace the front axle bolt to provide caster and pinion angle (up to $\pm 3^\circ$ total change). NOTE: Our **#82380** is for 1997 - 06 Wrangler TJs, 1993 - 98 Grand Cherokees and 1994 - 98 Ram Trucks *with 36mm cams*.

To elongate OEM bolt holes on the **#82390** use our knock out punch - **74910**. Front caster will change as you adjust pinion angle. Use our offset pin joints (**23510-23540** - page 53) for additional caster adjustment and to adjust camber.



Parts

82385

DODGE CASTER CAMS (PR)

Dodge solid front axled 3/4 and 1-ton trucks equipped with non-adjustable or corroded lower control arm bolts can now replace their OEM bolts (**50mm cams**) with the 82385 Caster

Adjustment Cam Kit (pr). These replacement cam bolts provide caster and pinion adjustment up to $\pm 2.00^\circ$. Achieve desired alignment settings with or without suspension lift kits along with providing additional positive caster for improved tracking.



Front Adjustment range:

Caster $\pm 2.00^\circ$ Pinion $\pm 2.00^\circ$

Installation time: .4 hr/axle

Required: 1 kit per axle

APPLICATIONS

Dodge 4WD: 2003 - 13 2500 Ram
2003 - 13 3500 Ram
Dodge RWD: 2000 - 02 2500 Ram
2000 - 13 3500 Ram
w & w/o mono beam

82395

DODGE CASTER/PINION CAMS (PR)

Replace the non adjustable or corroded OE bolts on Dodge 3/4 and 1-ton trucks to get $\pm 1.5^\circ$ of caster and pinion angle change. Whether the truck is lifted or stock ride height, optimize caster and pinion angles for better tracking and axle/drive shaft position.

NEW



Front Adjustment range:

Caster $\pm 1.50^\circ$ Pinion $\pm 1.50^\circ$

Installation time: .4 hr/axle

Required: 1 kit per axle

APPLICATIONS

Dodge 4WD: 1994 - 99 2500 Ram
Dodge 4WD: 1994 - 99 3500 Ram
Dodge RWD: 1994 - 99 3500 Ram
with mono beam

83115

CAM KIT

To correct camber remove the O.E. lower control arm attaching bolt and move arm away from the bracket. Using **73010** Punch, enlarge the hole in the bracket and re-attach the lower control arm using the correct mm bolt. To adjust, rotate the cam bolt.



Front Adjustment range: Camber $\pm .75^\circ$

Installation time: .8 hr/side Req.: 1 kit per axle

APPLICATIONS

See application charts, pages 7-45 for years.

BMW: 1963 - 88 Vehicles w/14mm bolt

Datsun: 240Z, 260Z, 280Z, 810

Nissan: 200SX, 280ZX, 300ZX, Maxima



73010 - Punch,
pg 129

NOTE: Make sure bolt is long enough before cutting hole.

83160

CHRYSLER/ FORD/GM O. E. REPLACEMENT CAMBER/ CASTER KIT (PAIR)

These cams are used as an O.E. replacement on the front and/or rear of vehicles listed.



Adjustment range: See Applications below

Installation time: .4 hr/side Req.: 1 kit per wheel

APPLICATIONS

Front camber or caster Adjustment range: $\pm 2.00^\circ$

Chrysler: 1960 - 73 all cars

Dodge: 1960 - 73 all cars (except B & E bodies); 1972 - 89 AD150
1972 - 87 D100, D150, D200, D250, D300, D350, D400, D450
1974 - 87 Ramcharger

Plymouth: 1960 - 73 all cars; 1974 - 81 Trailduster

Front camber Adjustment range: $\pm 2.00^\circ$

Ford: 1966 - 70 Fairlane, Falcon; 1966 - 71 Torino
1967 - 73 Mustang; 1967 - 79 Maverick

Mercury: Cougar 1969 - 77; 1966 - 70 Montego; 1967 - 79 Comet
1975 - 80 Granada/Monarch

Rear camber Adjustment range: $\pm 2.00^\circ$

Chevrolet: Corvette 1963 - 82

83170

FRONT CAMBER KIT (2)

These heavy duty adjusters provide up to $\pm 2.5^\circ$ front camber change for Chrysler/Dodge/Plymouth Mini-Vans and FWD cars along with VW Routans.



85130 - Rotary
File Set, pg 133

Front Adjustment range: Camber $\pm 2.50^\circ$

Installation time: .4 hr/side Req. 1 kit per axle

APPLICATIONS

Chrysler/Dodge/Plymouth:

1996 & up Mini-Vans (Caravan, Town & Country, Voyager)

2012 - 13 FWD/AWD Ram Cargo Van

1980 - 95 FWD 400, 600, Acclaim, Caravelle, Charger, Daytona, Dynasty, E Class, Fifth Ave., Imperial, Horizon, Lancer, New Yorker, Rampage, Reliant, Scamp, Shadow, Spirit, Sundance, TC3, Turismo

Volkswagen: 2009 & Up Routan

1-800-525-6505

Call for your nearest distributor, product info or
Technical Assistance • In the USA and Canada

www.specprod.com



Front Adjustment range:
Camber $\pm 1.50^\circ$ Caster $\pm 1.50^\circ$

Installation time: .5 hr/axle

Required: 1 kit per wheel

APPLICATIONS

- Chevrolet 4WD:** 1982 - 04 Blazer, S-10, Typhon
- GMC 4WD:** 1982 - 04 Envoy, Jimmy, Sonoma
- Isuzu 4WD:** 1997 - 98 Hombre
- Oldsmobile AWD:** 1991 - 01 Bravada

CHEVY/GMC CASTER/ CAMBER ADJ. KIT (PR)

83710

The 83710 is a stock OE replacement cam/bolt kit for the popular 4WD Chevy S-10/Blazer and GMC Sonoma/Jimmy. Adjust $\pm 1.25^\circ$ camber and caster with this simple to use set-up.



Front Adjustment range:
Camber/Caster $\pm 2.00^\circ$

Installation time: .5 hr/side

Required: 1 kit per wheel

APPLICATIONS

Chevrolet/GMC

- AWD:** 1990 - 05 Astro/Safari Van
- 4WD:** 1988 - 00 1500, 2500, 3500
(99-00 Classic Only)
- RWD/4WD:** 1992 - 04 Blazer (full size)
1988 - 91 Jimmy (full size)
1995 - 90 Tahoe
- RWD:** 1990 - 02 Express/Savana Van

GM HEAVY DUTY CAM/CAS KIT (PR)

83790

These heavy duty cam bolts replace the upper control arm mounting bolts. This kit has the added convenience of slip-on cams which makes installation easier. Remove the O.E. Bolts and replace them with these cams, rotating to provide camber and caster adjustment. Use **74910** punch to remove the O.E. slugs and elongate the holes. If necessary, **87400** includes 4 cam and bolt assemblies to cover both sides of the vehicle (page 88).



 **74910 - Punch, pg 129**

Front Adjustment range:
Caster $- .125^\circ$ to $- .25^\circ$

Installation time: .5 hr/side

Required: 1 spacer per wheel

APPLICATIONS

- Acura:** 1996 - 99 CL; 1996 - 03 TL
- Honda:** 1990 - 02 Accord
1995 - 98 Odyssey

HONDA CASTER SPACERS

These spacers change caster approximately $1/8^\circ$ (**84690**) and $1/4^\circ$ (**84695**). Adding spacers between the strut rod assembly and the large washer repositions the lower control arm to decrease caster. Removing them increases caster. Each part number comes in a package of ten with complete instructions.

84690 1/16" thick

84690 84695

84695 1/8" thick

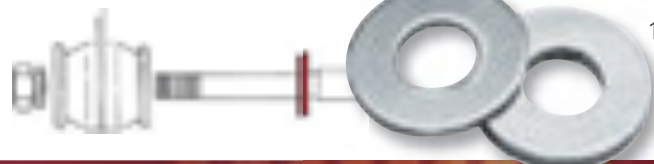

Rear Adjustment range:
Toe $\pm 1.00^\circ$

Installation time: .5 hr/axle

Required: 1 kit per axle

APPLICATIONS

- Saturn:** 1991 - 02 S-Series

SATURN REAR TOE KIT

The **85600** kit of two cam bolts replaces the inner mounting bolts on the rear parallel arms. This allows adjustments on rear toe up to 1° positive or negative. No grinding on the trailing arm bracket is required.



85600



Tech Tips

Take advantage of our experience! We have numerous articles written by our ASE certified mechanics that can help you install a part. Look for our "Tech Tip" icon and go to www.specprod.com to look up your part online and check out the 'Tip'

1. Always use the correct torque.
2. Always use the correct torque wrench.



Parts

85690 85695

TOYOTA CASTER SPACERS

These spacers change caster approximately 1/8° (85690) and 1/4° (85695). For Toyota models with stabilizer bushings at the lower control arms. Adding spacers to the stabilizer bar decreases caster and removing them increases caster. Each part number comes in a package of ten with complete instructions.



Front Adjustment range:
Caster $-.125^{\circ}$ to $-.250^{\circ}$

Installation time: .2 hr/side

Required: 1 spacer per wheel

APPLICATIONS

Toyota: All models w/ stabilizer bar at the lower control arms

86140 EXPLORER/MOUNTAINEER FRONT CAM./CAS/ KIT



Caster and camber adjustments can be made easily by installing this kit. By replacing the stock alignment washers on the upper control arms, caster and camber can be adjusted by turning the cam nuts to obtain the proper readings. These cam kits give you the full range of caster and camber adjustment and once installed can make alignment changes for the life of the vehicle.

Front Adjustment range:
Camber $\pm.75^{\circ}$ /Caster $\pm 1.25^{\circ}$

Installation time: .4 hr/side

Required: 1 kit per axle

APPLICATIONS

Ford: 2002 - 05 Explorer
Lincoln: 2003 - 05 Aviator
Mercury: 2002 - 05 Mountaineer

86180 EXPLORER/MOUNTAINEER REAR CAMBER KIT



This camber adjuster lets you easily adjust camber on the Explorer/Mountaineer fully independent rear suspension systems. Full range of camber adjustment can be made by replacing the stock alignment washer on the rear lower control arm and installing the plate and cam nut. Camber can then be adjusted by turning the cam nut until the desired readings are obtained.

Rear Adjustment range:
Camber $\pm.50^{\circ}$

Installation time: .2 hr/side

Required: 1 kit per axle

APPLICATIONS

Ford: 2002 - 05 Explorer
Lincoln: 2003 - 05 Aviator
Mercury: 2002 - 05 Mountaineer

86250 FORD ADJUSTABLE CAM NUT/ BRACKET



The innovative cam nut and sturdy bracket saves time and money. Easily adjust camber and caster on F150's from '04 and up (including late model) and '07 & up Expeditions. No need to remove the OE bolt or stabilizer bar. The sturdy guide bracket allows for live adjustment. This is a must have for every 2004 and up F150 and 2007 and up Expedition.

Front Adjustment range:
Camber $\pm 1.00^{\circ}$ Caster $\pm 1.50^{\circ}$

Installation time: .3 hr/side

Required: 1 kit per wheel

APPLICATIONS

Ford RWD/4WD:
2007 & Up Expedition
2004 & Up F150
Lincoln:
2002 - 03 Blackwood
2006 - 09 Mark LT
2003 & Up Navigator



86255 F150 PINION ANGLE SHIMS



This wedge-type shim fits the 2 hole design of this platform between the rear spring and the axle to change pinion angle. Perfect to align the driveline on vehicles that have been lowered or lifted.

Rear Adjustment range: Pinion $\pm 2.50^{\circ}$

Installation time: .5 hr/axle Req.: 1 kit per axle

APPLICATIONS

Ford: 2007 & Up Expedition; 2004 & Up F150
Lincoln: 2006 - 09 Mark LT; 2007 & Up Navigator



64225 - Angle Gauge, pg 127



Locks in OEMA adjustment

Installation time: .3 hr/side Req.: 1 kit per wheel

APPLICATIONS

Cadillac RWD/4WD: 2002 & Up Escalade

Chevrolet/GMC RWD/4WD: 1999 & Up 1500 & 1500HD Crew Cab; 1999 - 10 2500, 3500; 2002 & Up Avalanche 1500, 2500; 2004 - 13 Canyon & Colorado 2003 - Up Express/Savana Van; 2000 & Up Suburban, Tahoe, Yukon, Yukon XL (1500, 2500)

Hummer AWD: 2002 - 09 H2; 2006 - 10 H3, H3T

GM ALIGNMENT CAM LOCK PLATE

86320

This lock plate is designed to keep the front alignment angles in position by replacing the existing slotted cam. For newer models of GMC's 1500, 2500 and 3500 vehicles.

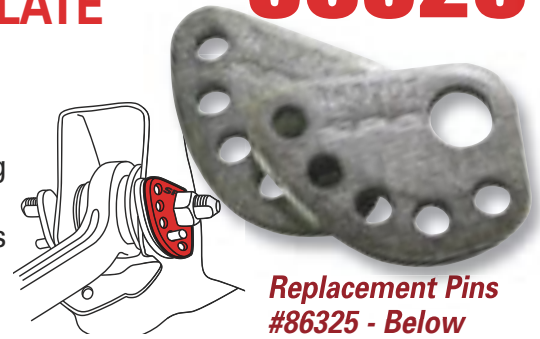

Replacement Pins #86325 - Below

Replacement Part

Installation time: .3 hr/side 8 pins per package

APPLICATIONS

Cadillac RWD/4WD: 2002 & Up Escalade

Chevrolet/GMC RWD/4WD: 1999 & Up 1500 & HD Crew Cab; 1999 - 10 2500, 3500; 2002 & Up Avalanche 1500, 2500; 2004 - 13 Canyon & Colorado 2003 - Up Express/Savana Van; 2000 & Up Suburban, Tahoe, Yukon, Yukon XL (1500, 2500)

Hummer AWD: 2002 - 09 H2; 2006 - 10 H3, H3T

GM ALIGNMENT PINS

86325

These pins replace the alignment pins in the GM vehicles listed. The pins make it easier to align the vehicle and often become bent or crushed and need to be replaced.

Includes 8 pins.



Front Adjustment range: Camber $\pm 1.00^\circ$

Installation time: .8 hr/side Req.: 1 kit per wheel

86330 APPLICATIONS

Chevrolet/GMC RWD/4WD:

2001 - 06 1500HD Crew Cab; 1999 - 10 2500, 3500 2002 - 06 Avalanche 2500; 2000 & Up Suburban 2500 2000 & Up Yukon XL 2500

Hummer AWD: 2002 - 09 H2

86350 APPLICATIONS

Cadillac RWD/4WD: 2002 & Up Escalade

Chevrolet/GMC RWD/4WD: 1999 & Up 1500 1988 - 00 1500, 2500, 3500 (1999-00 'Classic' only) 2002 & Up Avalanche 1500; 1992 - 94 Blazer (full size) 2003 - 13 Express/ Savana Van; 1988 - 91 Jimmy (full size); 1992 & Up Suburban 1500; 1995 & Up Tahoe 1992 & Up Yukon; 2000 & Up Yukon XL 2500

GM RWD/4WD FRONT CAMBER BUSHINGS

86330 86350

Replace the upper OE bushings with these offset control arm bushings to get $\pm 1.0^\circ$ of additional camber change. OE style rubber maintains the original ride characteristics.



79500 - Bushing Sleeves, pg 131
72509 - Ball Joint Press, pg 129

Front Adjustment range: Camber $\pm 1.50^\circ$ /Caster $\pm 1.50^\circ$

Installation time: .5 hr/side

Required: 1 kit per wheel

APPLICATIONS

Chevrolet: 2004 & Up Colorado

GMC: 2004 & Up Canyon

Hummer: 2006 - 10 H3, H3T

Isuzu: 2006 - 08 i350/i370

GM MID-SIZED CAMS

86360

GM's late-model mid-sized 4WD's have very little clearance to adjust the camber and caster with the OE adjusting cams. These specially designed adjusters replace the OE adjusters, and feature a 3/8" square drive hole, allowing fast and easy "on-the-vehicle" adjustments with any standard breaker bar. The unique design saves time by installing onto the OE bolt - no need to replace the bolt - and allows for quick future adjustments.

Replacement Pins #86325 - Above

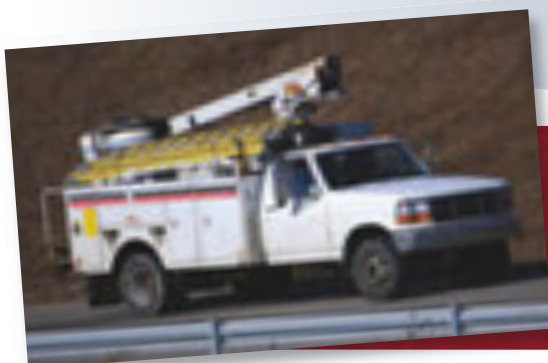
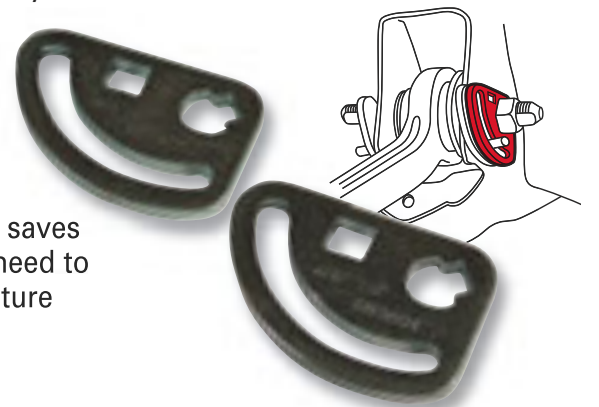

Specialty Products Works! SPC parts and tools are used in commercial fleets worldwide. Fleet specialists know that aligning their vehicles correctly prolongs tire life, increases fuel mileage and improves handling and tracking.



86370

GM VAN ALIGNMENT CAM PLATE (EACH)



Replacement Pins
#86325 - page 85

Designed to be easily adjusted with a 3/8" drive breaker bar, this cam makes the difficult to align 2003 and up GMC Savana and Chevy Express Vans a snap. Simply replace the OE cam on the forward bushing with this cam and you will be able to dial in camber and caster. These cams can also be used as replacement cams for 1999 & up full size Chevrolet/GMC Trucks and SUVs.

Front Adjustment range:
Camber $\pm 1.50^\circ$ /Caster $\pm 1.50^\circ$

Installation time: .3 hr/side

Required: 1 kit per wheel

APPLICATIONS

Chevrolet/GMC RWD/4WD:
2003 & Up Express & Savana Van
1500, 2500, 3500

86375

GM REPLACEMENT FRONT ALIGNMENT PLATE AND CAM (PAIR)



Replacement Pins
#86325 - page 85

The **86375** kit is a stock OE replacement cam/bolt kit for newer GM 1/2, 3/4, and 1 ton truck and van applications. These kits are for camber and caster adjustment. Fast, simple installation. For additional change see our bushings **86330** & **86350** (page 85) or our new adjustable ball joint **23960** (page 54).

Front Adjustment range: Camber/Caster $\pm 1.50^\circ$

Installation time: .3 hr/side Req.: 1 kit per wheel

APPLICATIONS

Cadillac RWD/4WD: 2002 & Up Escalade
Chevrolet/GMC RWD/4WD: 1999 & Up 1500 & HD Crew Cab; 1999 - 10 2500, 3500; 2002 & Up Avalanche 1500, 2500; 2004 - 13 Canyon & Colorado
2003 - Up Express/Savana Van; 2000 & Up Suburban, Tahoe, Yukon, Yukon XL (1500, 2500)
Hummer AWD: 2002 - 09 H2; 2006 - 10 H3, H3T

86640

FRONT CAMBER/CASTER EXPEDITION KIT



This kit allows for easy adjustment of the lower control arm to make camber and caster changes. Uses the OE bolts with the new cams and adjusting plates to give you lifetime camber and caster adjustments.

83820 - Adjusting Wrench, pg 132

Front Adjustment range:
Camber $\pm 1.00^\circ$ /Caster $\pm 1.50^\circ$

Installation time: .4 hr/side

Required: 1 kit per wheel

APPLICATIONS

Ford: 2003 - 06 Expedition
Lincoln: 2003 - 06 Navigator

86680

REAR CAMBER EXPEDITION KIT



This rear camber kit replaces the bolt on the upper control arm near the wheel. The adjusting plate locks into existing holes in the rear knuckle assembly making this a very easy-to-use and time saving kit.

Rear Adjustment range:
Camber $\pm 1.00^\circ$

Installation time: .3 hr/side

Required: 1 kit per wheel

APPLICATIONS

Ford: 2003 - 06 Expedition
Lincoln: 2003 - 06 Navigator

87270

RESILIENT RADIUS ARM TENSIONERS (PAIR)



Correct wander and extend radius arm bushing life on trucks with radius arms and strut rod suspensions with bushings 1/2" or thicker, and approx. 2-1/4" diameter.

Installation time: .4 hr/side

Required: 1 kit per axle

APPLICATIONS

Ford: Twin I-Beam - Installed next to bushing, behind the washer and nut.

87280

FORD TRUCK RWD CASTER KIT



This part (number **87280**) fits many late model Ford truck and vans with 20mm bolts. With this kit you can adjust caster up to $\pm 2.0^\circ$.

Front Adjustment range: Caster $\pm 2.00^\circ$

Installation time: .7 hr/side Req.: 1 kit per axle

APPLICATIONS

Ford RWD: 1992 - 98 E-Series Vans; 1987 - 96 F150
1992 - 96 F250; 1992 - 98 F350; 1990 - 97 Rangers
Mazda RWD: 1994 - 97 'B' Pickup; 1991 - 94 Navajo

Applications

Parts

Heavy Duty

Backing/Off Road

Tools

Accessories

Brake & CV

Gear/Index

Front Adjustment range:
Camber $\pm 1.75^\circ$ / Caster $\pm 1.75^\circ$

Installation time: .3 hr/side Req.: 1 kit per axle

APPLICATIONS

Ford RWD/4WD: 1995 - 01 Explorer
2001 - 05 Explorer Sport Trac; 1998 - 00 Ranger
Mazda RWD/4WD: 1998 - 12 B-Series Pickup
Mercury RWD/4WD: 1996 - 01 Mountaineer

EXPLORER CAMBER/ CASTER KIT (4)

87310

This set of 4 cams allows for quick installation without having to remove the upper control arm bolt. Change camber and caster up to $\pm 1.75^\circ$.

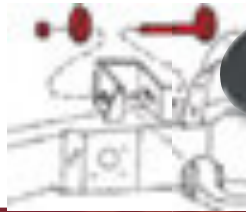

Rear Adjustment range:
Camber $\pm 1.00^\circ$ Toe $\pm 1.00^\circ$

Installation time: .5 hr/side

Required: 1 kit per axle

APPLICATIONS

Ford: 1986 - 06 Taurus Sedan
Mercury: 1986 - 06 Sable Sedan

 **8370 - Tie Rod Puller, pg 123**
 **87320 - Bushing Adj. Tool, pg 134**

TAURUS/SABLE SEDAN REAR CAMBER-TOE KIT (4)

87330

To change rear camber and toe on 1986 - 06 Taurus and Sable sedan, use our kit which allows up to $\pm 1.0^\circ$ change in camber and 1/2" toe change. Remove the O.E. bushings and toe adjusters on the inner pivot points and replace with the eccentric bushings. Rotate the bushings to adjust camber and/or toe.



Rear Adjustment range:
Camber $\pm 2.50^\circ$

Installation time: .5 hr/side

Required: 1 kit per axle

APPLICATIONS

Ford: 1986 - 05 Taurus Station Wagon
Mercury: 1986 - 05 Sable Station Wagon

TAURUS/SABLE WAGON REAR CAMBER KIT

87350

This kit provides camber change up to $\pm 2\frac{1}{2}^\circ$ on each rear wheel of Ford Taurus and Mercury Sable Station Wagons Only. After replacing the inner lower control arm bolt and elongating the hole, install the **87350** cam bolt and rotate the head to adjust camber.

 **85130 - Rotary File, pg 133**





Front Adjustment range:
Camber $\pm 2.5^\circ$
($\pm 1.5^\circ$ more than stock change)

Installation time: .8 hr/side

Required: 1 kit per wheel

APPLICATIONS

Ford: 2003 - 12 Crown Victoria/Fleet
Lincoln: 2003 - 11 Town Car
Mercury: 2003 - 11 Grand Marquis
2003 - 04 Marauder

 **85130 - Rotary File, pg 133**
 **02099 - Boot Clamp, pg 142**

FORD, MERCURY, LINCOLN CAMBER ADJ. BOLT

87365

The 87365 Adjustable Camber Kit allows additional camber changes up to $\pm 1.5^\circ$ for a total of $\pm 2.5^\circ$, on the popular Ford Crown Victoria, Mercury Marquis, and the Lincoln Town Car. Sagging of the suspension on these heavyweight vehicles is normal and routinely causes negative camber problems. Elongating the cam slots is completed in seconds using the new **85137** 3/8" Rotary File for Aluminum.

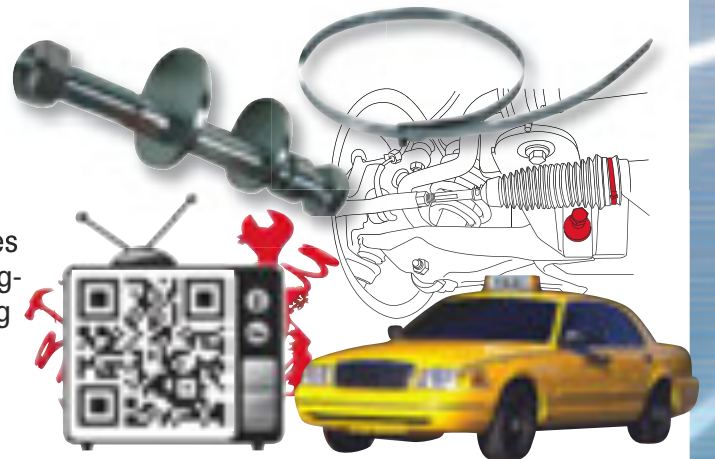

Front Adjustment range:
Camber $\pm 2.00^\circ$ / Caster $\pm 2.00^\circ$

Installation time: .4 hr/side

Required: 1 kit per axle

APPLICATIONS

Ford RWD/4WD: 1997 - 02 Expedition
1997 - 03 F150; 2004 F150 Heritage
1997 - 99 250 (LD)
Lincoln RWD/4WD:
1998 - 02 Navigator

F150/F250 (L/D) CAMBER/CASTER KIT (4)

87385

Use this kit to change caster and/or camber on these vehicles. Simply replace the existing upper control arm mounting bolts with these cam bolts for caster/camber changes up to $\pm 2.0^\circ$.



Parts

87400

GM RWD/4WD CAM/CAS KIT (4)



These heavy duty cams replace the upper control arm mounting bolts. Remove the O.E. bolts and replace with cams, rotating to provide camber and/or caster adjustment. It may be necessary to remove O.E. slugs and elongate the bolt holes with **74910** punch. **83790** includes 2 cams to cover one side of the vehicle (page 83).



74910 - Punch, pg 129

Front Adjustment range:
Camber $\pm 2.00^\circ$ /Caster $\pm 2.00^\circ$

Install. time: .4 hr/side Req.: 1 kit per axle

APPLICATIONS

Chevrolet/GMC

AWD: 1990 - 05 Astro/Safari Van

4WD: 1988 - 00 1500, 2500, 3500
(1999-00 Classic Only)

RWD/4WD: 1992 - 04 Blazer (full size)
1988 - 91 Jimmy (full size); 1995 - 1990 Tahoe

RWD: 1990 - 02
Express/Savana Van

87420

GM REAR CAM NUT



This cam nut replaces the non-adjustable nut on the rear lower control arm of GM's Theta platform. The offset nut provides $\pm 1^\circ$ of toe change when used in conjunction with the stock camber nut. This kit can also be used as a replacement rear camber nut.

Rear Adjustment range: Toe $\pm 1.00^\circ$

Install. time: .3 hr/side Req.: 1 kit per wheel

APPLICATIONS

Chevrolet/GMC: 2012 & Up Captiva
2005 & Up Equinox; 2005 & Up Terrain

Pontiac: 2006 - 09 Torrent

Saturn: 2006 - 09 Vue

Suzuki: 2007 - 11 XL-7

87430

CHEVY CAMARO/PONTIAC G8 ADJ. REAR CAM

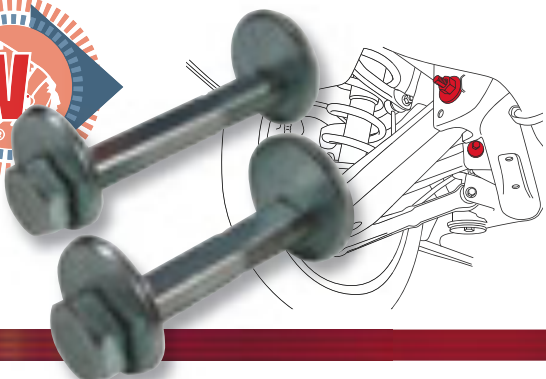

Double the range of rear camber and toe adjustment on the popular Camaro to increase handling performance and minimize tire wear. Remove and replace the OE cam bolts with our 87430 kit for $\pm 1.0^\circ$ camber change and $\pm 2.0^\circ$ toe change. No slotting or grinding needed!

Rear Adjustment range:

Camber $\pm 1.00^\circ$ Toe $\pm 2.00^\circ$

Installation time: .6 hr/side

Required: 1 kit per wheel

APPLICATIONS

Chevrolet: 2010 & Up Camaro
2011 & Up Caprice PPV
2014 & Up SS

Pontiac: 2008 - 09 G8

87500

FORD EXPLORER CAMBER/CASTER KIT (4)



These Ford Explorers and Rangers have a torsion bar suspension with limited caster and no camber adjustment. This kit will provide up to 2° positive or negative camber/caster adjustment. Simply replace the O.E. upper control arm mounting bolts with the **87500** cam bolts for fast and efficient adjustment now and in the future. One kit covers both sides of the vehicle.

Front Adjustment range:

Camber $\pm 2.00^\circ$ /Caster $\pm 2.00^\circ$

Installation time:

Passenger Side: .4 hr/side

Driver Side: .7 hr/side

Required: 1 kit per axle

APPLICATIONS

Ford RWD/4WD: 1995 - 01 Explorer
2001 - 05 Explorer Sport Trac
1998 - 00 Ranger

Mazda RWD/4WD:
1998 - 12 B-Series Pickup

Mercury RWD/4WD:
1996 - 01 Mountaineer

87520

NISSAN CAMBER/ CASTER KIT (2)



These cams are designed to install in the lower control arms for camber and caster adjustment. They replace the original non-adjustable lower control arm bolts.

Front Adjustment range:

Camber $\pm 2.00^\circ$ /Caster $\pm 2.00^\circ$

Install. time: .3 hr/side Req.: 1 kit per wheel

APPLICATIONS

Infiniti RWD/4WD: 2005 & Up QX56

Nissan RWD/4WD: 2004 & Up Armada, Titan
2005 & Up Frontier, Xterra; 2005 - 12 Pathfinder

Suzuki RWD/4WD: 2009 -12 Equator

1-800-525-6505 Call for your nearest distributor, product info or
Technical Assistance • In the USA and Canada

www.specprod.com

Front Adjustment range:
Camber $\pm 1.25^\circ$

Installation time: .2 hr/side

Required: 1 kit per wheel

APPLICATIONS

Ford: 1989 - 97 Thunderbird

Lincoln: 1993 - 98 Mark VIII

Mercury: 1989 - 97 Cougar

T-BIRD, MARK VIII, COUGAR REPLACEMENT FRONT CAM KIT

Use this stock replacement Cam Kit on the front lower arm to achieve $\pm 1.25^\circ$ front camber change on tenth generation Thunderbirds and associated Cougars, and Mark Vllls. Kit provides easy and precise adjustment without any further modifications.



87535

Front Adj. range: Camber $\pm 1.00^\circ$ /Caster $\pm 2.00^\circ$

Installation time: .4 hr/side Req.: 1 kit per axle

APPLICATIONS

87540 Ford: 2002 - 06 Thunderbird

87545 Lincoln: 2000 - 06 LS

T-BIRD/LS FRONT CAM/CAS KIT

These kits install in the lower control arms and provides easy and precise adjustment for caster and camber without any further modifications.



87540 87545

Front Adj. range:

88901	Cam./Cas. $\pm 1.20^\circ$
88902	Cam./Cas. $\pm 1.50^\circ$
88903	Cam./Cas. $\pm 1.80^\circ$
88904	Cam./Cas. $\pm 2.20^\circ$

Installation time: 1.4 hr/side

Required: 1 per wheel

APPLICATIONS

Toyota 4WD: 1985 - 90 Landcruiser 40, 60, 70 Series

TOYOTA MONOBEAM

These sleeves fit Toyota 4WD with series 40, 60, or 70 monobeam axles. Dismantle the hub assembly and press out the upper and lower bearing races. Replace with the correct offset races. Install the new bearings and reassemble the hub.

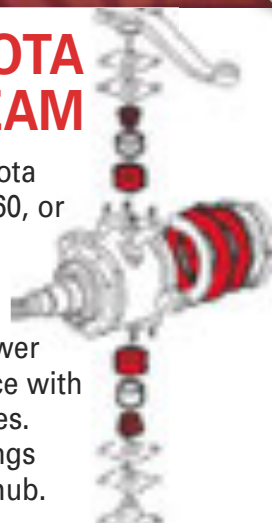

88901 88902 88903 88904

Front Adj. range:

88905	Cam./Cas. $\pm 1.00^\circ$
88906	Cam./Cas. $\pm 1.50^\circ$

Installation time: 1.4 hr/side

Required: 1 per wheel

APPLICATIONS

Suzuki 4WD: 1986 - 96 Samurai

SUZUKI SAMURAI 4WD

Samurai 4WD combination sleeves come in two different sizes to change camber, caster or both without causing a binding in the steering.

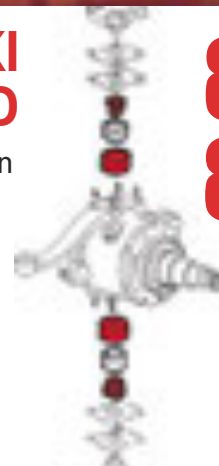

88905 88906

Front Adjustment range:

88915	Cam./Cas. $\pm 1.00^\circ$
88920	Cam./Cas. $\pm 3.00^\circ$

Installation time: 1.4 hr/side

Required: 1 kit per wheel

APPLICATIONS

Lexus: 1996 - 98 LX450

Toyota: 1990 - 97 Landcruiser 80 Series

TOYOTA FRONT OFFSET BEARING KIT

These offset bearing kits provide either 1° or 3° of camber and/or caster change for the non-adjustable Toyota Landcruiser 80 Series and Lexus LX450s with solid front axles. These vehicles are prone to caster loss when lifted, making the 3° kit perfect for adding caster to restore "return to center" and improve tracking.



88915 88920

Parts

88940
88950

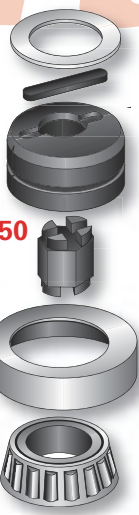

DANA 60 AXLE CAM/CAS KITS

These exclusive kits provide a camber and caster change for Dana 60 Axles. Replace the O.E. bushing with the correct eccentric bushing, rotate to adjust caster/ camber and lock in place. These kits provide full adjustment for future alignments.

Front Adj. range: **88940** Cam/Cas $\pm 1.00^\circ$
88950 Cam/Cas $\pm 1.50^\circ$

Installation time: **88940** .4 hr/side
88950 1.4 hr/side

Required: 1 per wheel

MONOBEAM - DANA 60 APPS

Chevrolet/GMC: 1988 - 93 K30, V30, V35

Dodge: 1975 - 93 W300/350

Ford: 1974 - 79 F250; 1974 - 91 F350

International: 1966 - 71 Pickup (1300)

89199-
89899

UNI-WEDGE SHIMS (HD ZINC ALLOY)

Twice the coverage - half the inventory. Changes caster positive or negative from $1/2^\circ$ to 4° . **APPS:** Any solid axle RWD or 4WD vehicle.

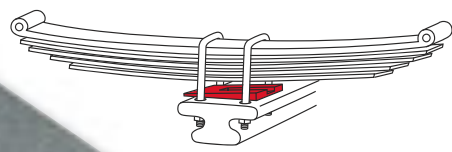
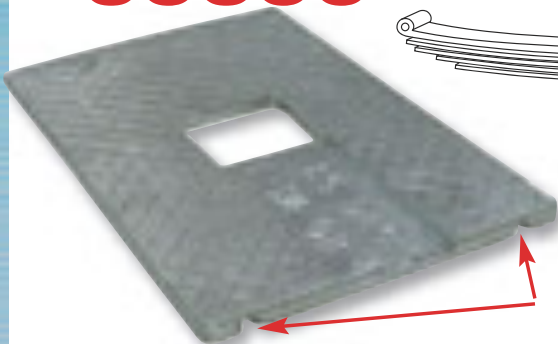

Double Breakaway

Part No.	Width	Degree Taper	Qty/Box
89199	3" - 3-1/2" - 4"	$1/2^\circ$	6
89299	3" - 3-1/2" - 4"	1°	6
89399	3" - 3-1/2" - 4"	$1-1/2^\circ$	6
89499	3" - 3-1/2" - 4"	2°	6
89599	3" - 3-1/2" - 4"	$2-1/2^\circ$	6
89699	3" - 3-1/2" - 4"	3°	6
89799	3" - 3-1/2" - 4"	$3-1/2^\circ$	6
89899	3" - 3-1/2" - 4"	4°	6

For additional shim widths see page 78

Note: Ordering one Part Number supplies six shims in a box.

89635

TAURUS/SABLE FRONT KIT (PR)



This kit provides front camber adjustment on popular Ford Taurus and Mercury Sable sedans. Camber adjustment up to 1.25° . These plates are sold in pairs, one for each side of the vehicle.

Front Adjustment range: Camber 0° to $+1.25^\circ$

Installation time: 1.0 hr/side

Required: 1 kit per axle

APPLICATIONS

Ford: 1996 - 06 Taurus Sedan
1996 - 05 Taurus Wagon

Mercury: 1996 - 06 Sable Sedan; 1996 - 05 Sable Wagon



89675

CONTOUR/COUGAR FRONT CAMBER/CASTER KIT



Now you can bring the front camber and caster back into specs with this adjustable strut mount. Simply replace the original upper strut mount with the **89675** and rotate the adjustable plate to bring your alignment back to OE specs. Future adjustments can be made without removing the strut.

Front Adjustment range: Camber $\pm 1.00^\circ$ /Caster $\pm 1.00^\circ$

Installation time: 1.2 hr/side

Required: 1 kit per wheel

APPLICATIONS

Ford: 1995 - 00 Contour

Mercury: 1999 - 02 Cougar
1995 - 00 Mystique

89685

FORD WINDSTAR CAMBER KIT (PAIR)



This kit provides front camber adjustment on this popular mini-van. Camber adjustment of up to 1.25° . These plates are sold in pairs, one for each side of the vehicle.

Front Adjustment range: Camber 0° to $+1.25^\circ$

Installation time: 1.0 hr/side

Required: 1 kit per axle

APPLICATIONS

Ford: 2004 - 07 FWD Freestar
1994 - 03 Windstar

Mercury: 2004 - 07 Monterey

SPC Knows Muscle

Bring modern handling and adjustability to your classic muscle car. By replacing your front upper and lower control arms and adding high performance springs you can once again enjoy driving your muscle car.



Mustang II Suspensions

With both Adjustable Upper Control Arms and Tubular Lower Control Arms SPC Performance Pro Series will meet your Mustang II Street Rod needs. You can easily adjust the upper arms for maximum handling and minimized tire wear. Arms include everything needed for your custom chassis including ball joints. Stock or 2" dropped spindles are available separately.

Part #	Description
93000	Mustang II LCA for Coilover Suspension - LEFT
93010	Mustang II LCA for Coilover Suspension - RIGHT
93040	Mustang II LCA for Stock Style Suspension - LEFT
93050	Mustang II LCA for Stock Style Suspension - RIGHT
94000	Mustang II Adj. UCA for Coilover Suspension - L or R
94800	Mustang II Adj. UCA for Stock OR Air Ride Susp. - L or R
93020	Mustang II Stock Forged Spindle - LEFT
93030	Mustang II Stock Forged Spindle - RIGHT
93080	Mustang II 2" Dropped Spindle - LEFT
93090	Mustang II 2" Dropped Spindle - RIGHT



Ball Joints

.5" Extended Length OEM Style Ball Joints



These greaseable, OEM style extended length ball joints are ideal to improve camber gain and increase control arm to frame clearance.

Ideal for the ultimate in handling performance.

Part #	Moog Equiv	Description
94016	K5103.5	Lower Ball Joint for GM 'A' Bodies (Press in for 94344 Lower Arm)
94018	K6145.5	Lower Ball Joint for GM 'G' Bodies (Press in for 95336 Lower Arm)
94017	K5208.5	Upper Ball Joint for GM Mid Size Bolt In Metric Plate
94019	K5108.5	Upper Ball Joint for GM 1st Gen 'F' Body & 'A' Body ('64 -'72)

OEM Style Ball Joints

These ball joints fit a variety of GM and Chrysler applications. If you are installing our Adjustable Control Arms these ball joints are the perfect fit to finish your suspension upgrade or a direct fit to replace a worn ball joint on a stock arm.

Part #	Moog Equiv	Description
94002	K772	Upper Chrysler Screw-In Ball Joint  68880 - Socket pg 128
94003	K6034	Upper GM C2/C3 Corvette & Tri 5 Bolt-In Ball Joint
94004	K6024	Upper GM Full-Sized Bolt-In Ball Joint
94006	K5208	Upper GM Mid-Sized Metric Bolt-In Ball Joint
94007	K6346	Upper C4 Corvette Bolt-In Ball Joint
94008	K719	Lower Chrysler Screw-In Ball Joint  68880 - Socket pg 128



Parts

SPC PERFORMANCE

GM Muscle Car Adjustable Upper Control Arms

NEW Components

SPC Performance offers fully adjustable, rugged upper control arms to adjust your front end and meet your exact needs. These arms provide quick and easy adjustment for standard or lowered heights. Fine tune your handling and alignment while minimizing tire wear. Perfect for Pro Touring as well as track or street use. **Sold as individual arms.**



New, upgraded threaded chromoly cross shafts accept both our standard OE style pivots or our Premium Pivots



Optional Premium Low-Friction Offset Pivots with Greaseable Delrin Sleeves are available for all our GM Muscle Car Arms - Optimizing your suspension with race-type quality. Part No. 92025



Optional Premium Extended Length Ball Joint #94017 & #94019 (page 91) Standard Ball Joint #94006 (page 91)

'A' BODY



Ext. Range Ball Joint #94019
Stock Ball Joint #94006
Page 91

94320 Right or Left Stock Height Lowered vehicles Tall/Aftermarket Spindles

Includes a flat midsize plate, adjustable sleeves, OE style (minimal deflection) pivots.

Front Adj. range: Camber $\pm 3.00^\circ$ Caster $\pm 3.00^\circ$

Installation time: .7 hr/side Req.: 1 kit per wheel

APPLICATIONS

Buick: 1964 - 72 GS, Skylark, Special
Chevrolet: 1964 - 72 Chevelle, El Camino, Malibu 1970 - 72 Monte Carlo
Oldsmobile: 1964 - 72 442, Cutlass/Supreme
Pontiac: 1964 - 72 GTO, LeMans; 1964 - 70 Tempest

Lower Arms page 93, Pro Springs page 94

1ST GENERATION 'F' BODY



Ext. Range Ball Joint #94019
Stock Ball Joint #94006
Page 91

94305 Right or Left Stock Height Lowered vehicles Tall/Aftermarket Spindles

Includes a flat midsize plate, adjustable sleeves, OE style (minimal deflection) pivots.

Front Adj. range: Camber $\pm 3.00^\circ$ Caster $\pm 3.00^\circ$

Installation time: .7 hr/side Req.: 1 kit per wheel

APPLICATIONS

Buick: 1973 - 74 Apollo
Chevrolet: 1967 - 69 Camaro, 1968 - 74 Nova
Pontiac: 1967 - 69 Firebird

Lower Arms page 94, Pro Springs page 94

2ND GENERATION 'F' BODY



Ext. Range Ball Joint #94017
Stock Ball Joint #94006
Page 91

94340 Right or Left Stock Height Lowered vehicles Tall/Aftermarket Spindles

Includes a flat midsize plate, adjustable sleeves, OE style (minimal deflection) pivots.

Front Adj. range: Camber $\pm 3.00^\circ$ Caster $\pm 3.00^\circ$

Installation time: .7 hr/side Req.: 1 kit per wheel

APPLICATIONS

Buick: 1971 - 85 LeSabre; 1973 - 77 Century, Regal 1973 - 77 Grand National; 1975 - 75 Skylark
Chevrolet: 1970 - 81 Camaro, 1973 - 77 El Camino, Malibu, Monte Carlo, 1975 - 79 Nova
Oldsmobile: 1973 - 77 Cutlass/ Supreme 1975 - 79 Omega, 1971 - 77 88
Pontiac: 1971 - 76 Bonneville, 1970 - 81 Firebird 1973 - 75 Grand Am, 1973 - 77 Grand Prix, LeMans

Lower Arms page 94, Pro Springs page 94

'G' BODY



Ext. Range Ball Joint #94017
Stock Ball Joint #94006
Page 91

94332 Right or Left Lowered vehicles and Tall/Aftermarket Spindles

Includes a flat midsize plate, adjustable sleeves, OE style (minimal deflection) pivots.

Front Adj. range: Camber $\pm 3.00^\circ$ Caster $\pm 3.00^\circ$

Installation time: .7 hr/side Req.: 1 kit per wheel

APPLICATIONS

Buick: 1978 - 87 Grand National, Regal
Chevrolet: 1978 - 88 El Camino; 1978 - 83 Malibu 1978 - 88 Monte Carlo 1982 - 04 Blazer S Series, Jimmy S Series, S10/S15 Pickup/Sonoma (RWD)
Oldsmobile: 1978 - 88 Cutlass/Supreme
Pontiac: 1982 - 86 Bonneville; 1978 - 80 Grand Am 1978 - 87 Grand Prix; 1978 - 81 LeMans

Lower Arms page 95, Pro Springs page 94

Applications

Parts

Body/Drivetrain

Tools

Accessories

Brake & CV

Gear/Index

92



ADJUSTABLE ARM SPACER KITS

Ball Joint Spacers raise the arm to improve frame clearance. Three 1/4" spacers and hardware.

94304 For GM 'F', 'A', and 'G' Body Upper Control Arms

94306 For GM 1955 - 57 'Tri-5' Upper Control Arms



Front Fixed Change: Caster +1.00°

Install. time: 1.2 hr/side Req.: 1 kit per axle

Pro Springs #94391/94392 (pg. 95)

Coilover Mount/Spacer Kit #94346/94348 (pg. 95)

Coilover Mounts augment coil stability on SPC's tubular lower arms

APPLICATIONS

- Buick:** 1964 - 72 GS, Skylark, Special
Chevrolet: 1964 - 72 Chevelle, El Camino, Malibu
 1970 - 72 Monte Carlo
Oldsmobile: 1964 - 72 442, Cutlass/Supreme
Pontiac: 1964 - 72 GTO, LeMans
 1964 - 70 Tempest

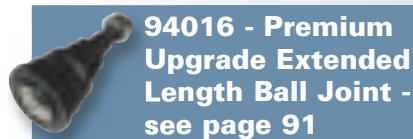

GM 'A' BODY TUBULAR LOWER ARMS (PR)

94344

SPC PERFORMANCE

These arms lower your front end by 1" and add 1° positive caster for a ready-to-run, aggressive stance. Optional Ride Height Tuning Kits are available for use with our Pro Series Springs or 'standard type' springs to raise the ride height if desired.

If you have coilovers use our Coilover Mount and Spacer Plate. Shown with optional OEM style bump stop (#95339 pg 95).



Front Adjustment range:
 Camber ±3.00° Caster ±3.00°

Installation time: .7 hr/side

Required: 1 kit per wheel

APPLICATIONS

Model/Year	Arm	Style
Impala (1958-72)	94360	Street R&L
Tri-5 (1955-57)	94350	Street R&L
C2/C3 (1963-82)	94360	Street R&L
C2/C3 (1963-82)	92740	Race R&L
C4 (1984-87)	94368	Street - Right
C4 (1984-87)	94369	Street - Left
C4 (1984-87)	92748	Race - Right
C4 (1984-87)	92749	Race - Left
C4 (1988-96)	94370	Street - Right
C4 (1988-96)	94371	Street - Left
C4 (1988-96)	92750	Race - Right
C4 (1988-96)	92751	Race - Left

Corvette & GM 'Tri-5' Adjustable Upper Control Arms

Adjust camber and caster for maximum handling and performance with our adjustable arms for Corvettes, Impalas and 'Tri-5' Bodies. Arms include a steel cross shaft with street style or race pivots and ball joint plate.

Street Style:

Includes Steel Cross Shaft with Custom Pivots and OE style (minimal deflection) pivots.

Race Style:

Steel Cross Shaft with Offset Race Pivots w/Delrin Inserts.



New, upgraded threaded chromoly cross shafts accept both our standard OE style pivots or our Premium Pivots



Optional Premium Low-Friction Offset Pivots with Greaseable Delrin Sleeves are available for our Corvette and 'Tri-5' Arms - Optimizing your suspension with race-type quality. Part No. 92025



Optional Ball Joints (not included - Pg 91)
 #94350 & #94360 uses #94003
 #94368/69 uses #94007
 #94370/71 uses #94007

Optional #94306 - "Tri-5" Spacer Kit Includes spacers and hardware



Todd Emeny's '68 Chevelle shows how it is done. Todd runs with SPC's upper and lower GM 'A' series arms, and enjoys great handling and tracking while being able to aggressively lower his stance for a great look

Savitske Classic and Custom owner and author of "How to Make Your Muscle Car Handle", Mark Savitske knew he could provide the owners of these classics the cornering performance and tractability they wanted. With SPC Performance's adjustable upper control arms and SPC tubular lowers, Savitske's customers have discovered the benefits of Pro-Touring, classic style with the improved handling and control of modern cars.



Parts

94374

1ST GEN. GM 'F' LOWER ARMS (PR)

SPC
PERFORMANCE.



These tubular arms are a perfect fit for 1st Gen 'F' Bodies and will lower your front end by 1" as well as add 1° positive caster for an aggressive, ready-to-run stance. Ride Height spacer and Coilover Mounts are available. To complete your arm add an OEM style bump stop (#95339 page 95).

Installation time: 1.2 hr/side

Required: 1 kit per axle

APPLICATIONS

Pro Springs #94393 (above)
Coilover Mount/Spacer Kit #94346/95348 (pg. 95)
Coilover Mounts augment coil stability on SPC's tubular lower arms

Buick: 1973 - 74 Apollo
Chevrolet: 1967 - 69 Camaro
1968 - 74 Nova
Pontiac: 1967 - 69 Firebird



94378

2ND GEN. GM 'F' LOWER ARMS (PR)

SPC
PERFORMANCE.



Our 2nd Gen 'F' lower arms feature a rugged formed plate body. To achieve an aggressive, ready-to-run stance, these arms will add 2.5° positive caster and may be configured for stock or lowered height. Ride Height spacer and Coilover Mounts are available. **Note: Shown with an optional OEM style bump stop (#95339 page 95).**

Installation time: 1.2 hr/side

Required: 1 kit per axle

APPLICATIONS

Pro Springs #94394 (above)
Coilover Mount/Spacer Kit #95332/95338 (pg. 95)
Coilover Mounts augment coil stability on SPC's tubular lower arms

Buick: 1971 - 76 LeSabre; 1973 - 77 Century, Grand National, Regal; 1975 - 75 Skylark
Chevrolet: 1970 - 81 Camaro; 1973 - 77 El Camino, Malibu, Monte Carlo; 1975 - 79 Nova
Oldsmobile: 1973 - 77 Cutlass/ Supreme 1975 - 79 Omega; 1971 - 77 88
Pontiac: 1971 - 76 Bonneville; 1970 - 81 Firebird 1973 - 75 Grand Am; 1973 - 77 Grand Prix, LeMans

94390

94391

94392

94393

94394

Pro Springs

SPC Performance Pro Spring Kit offers immediate handling enhancement and gives your muscle car an aggressive stance! Front springs provide approximately a **1.3" drop*** and rear springs **1.0" drop***. Highest quality and design assures springs will retain optimum rates for unsurpassed performance. Springs are epoxy coated with a diamond black color and have a lifetime warranty. Sold as a complete vehicle package. If you are using these springs with our lower arms, and need to fine tune your ride height use our Height Spacers (page 95).

Make	Model	Pro Springs	Ride Height Spacers
'A' Body - Set of 4 Springs - Front and Rear			
Buick	GS, Skylark, Special (64-67)	94391	94332/95348
Buick	GS, Skylark, Special (68-72)	94392	94332/95348
Chevrolet	Chevelle, El Camino, Malibu (64-67)	94391	94332/95348
Chevrolet	Chevelle, El Camino, Malibu, Monte Carlo (68-72)	94392	94332/95348
Oldsmobile	442, Cutlass, Cutlass Supreme (64-67)	94391	94332/95348
Oldsmobile	442, Cutlass, Cutlass Supreme (68-72)	94392	94332/95348
Pontiac	GTO, LeMans, Tempest (64-67)	94391	94332/95348
Pontiac	GTO, LeMans, Tempest (68-72)	94392	94332/95348
'F' Body - Set of 2 Springs - Front Only			
Buick	Apollo (73-74)	94393	94332/95348
Chevrolet	Camaro (67-69); Nova (68-74)	94393	94332/95348
Pontiac	Firebird (67- 69)	94393	94332/95348
Chevrolet	Camaro (70-81)	94394	94346/95348
Pontiac	Firebird (70-81)	94394	94346/95348
'G' Body - Set of 4 Springs - Front and Rear			
Buick	Grand National, Regal (78-87)	94390	94346/95348
Chevrolet	El Camino, Malibu, Monte Carlo (78-88)	94390	94346/95348
Oldsmobile	Cutlass, Cutlass Supreme (78-88)	94390	94346/95348
Pontiac	Bonneville (83-86); Grand Am (78-80) Grand Prix (78-88); LeMans (78-81)	94390	94346/95348

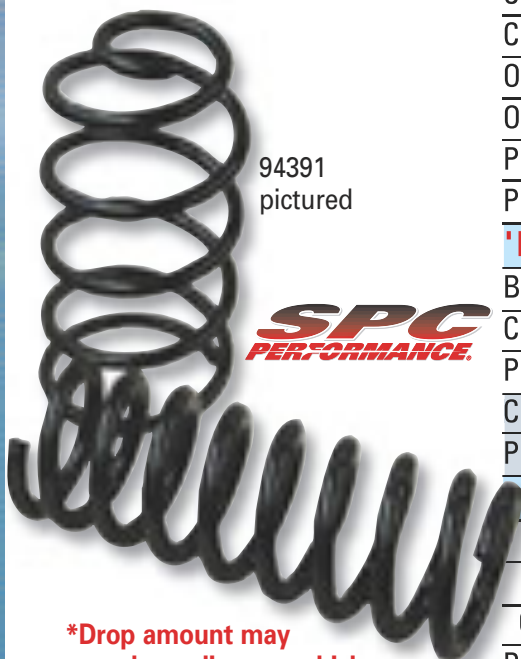

94391 pictured

*Drop amount may vary depending on vehicle weight, options, etc.)

1-800-525-6505

Call for your nearest distributor, product info or Technical Assistance • In the USA and Canada

www.specprod.com



Front Adj. range: Camber $\pm 3.00^\circ$ Caster $\pm 3.00^\circ$

Installation time: .7 hr/side Req.: 1 kit per wheel

APPLICATIONS

'B' & 'E' 94450 RIGHT 94451 LEFT

Dodge: 1962 - 65 All Passenger (except 880)
1970 - 74 Challenger; 1966 - 72 Charger
1965 - 72 Coronet; 1967 - 70 R/T
1962 - 64 Super Bee

Plymouth: 1962 - 64 All Passenger
1970 - 74 Barracuda; 1965 - 70 Belvedere
1967 - 71 GTX; 1968 - 72 Road Runner
1965 - 72 Satellite

'A' 94460 RIGHT 94461 LEFT

Dodge: 1972 - 76 Dart
Plymouth: 1972 - 75 Valiant



MOPAR 'A', 'B' & 'E' BODY ADJ. CONTROL ARM

These fully adjustable Upper Control Arms transform your classic Mopar from sluggish, non-responsive handling to high performance FUN! Dial in additional positive caster, adjust your camber, and enjoy the feel of up to 6 degrees adjustment! Arms include stock ball joints. Sold as individual arms. Ball joint is included.

Right

94450

Left

94451

Right

94460

Left

94461



Front Fixed Change:
Caster +1.00°

Installation time: 1.2 hr/side

Required: 1 kit per axle

Pro Springs #94390 (pg. 95)
Coilover Mount/Spacer Kit #95333/95338 (below)
Coilover Mounts augment coil stability on SPC's tubular lower arms

APPLICATIONS

Buick: 1978 - 87 Grand National, Regal
Chevrolet: 1978 - 88 El Camino; 1978 - 83 Malibu
1978 - 88 Monte Carlo
1982 - 04 Blazer S Series, Jimmy S Series,
S10/S15 Pickup/Sonoma (RWD)

Oldsmobile: 1978 - 88 Cutlass/Supreme
Pontiac: 1982 - 86 Bonneville; 1978 - 80 Grand Am
1978 - 87 Grand Prix; 1978 - 81 LeMans



94018 - Premium Upgrade Extended Length Ball Joint - see page 91



GM 'G' BODY LOWER CONTROL ARMS (PR)

95336

Improve your handling and tracking with these new tubular arms and lower your front end by 1" and add 1° positive caster for an aggressive, ready-to-run stance. Optional Coilover Mount/Spacer Kits are available for use with our Pro Series Springs or 'standard type' springs to raise the ride height if desired (#95332/95338). To complete your arm you can also add an OEM style bump stop (#95339 below).



95333 Height Tuning Kit w/aluminum spring seat

For SPC Arms 'G' Body LCAs with a urethane spring seat (see below)

APPLICATIONS

'A' Bodies & 1st Gen. 'F' Bodies

94348 2 Spacers

94346 4 Spacers

2nd Gen. 'F' Bodies & 'G' Bodies

95538 2 Spacers

95332 4 Spacers

'G' Bodies (With urethane spring seat)

95333

Height Tuning Kit with aluminum spring seat & 4 spacers



COILOVER MOUNT/SPACER PLATES

These Flat Coil Spring Mount/Spacer Plates are designed to maximize your ride height options. Use these plates as coilover mounts to augment coil stability on SPC's tubular lower arms. If you need to fine-tune your ride height these plates can also be stacked to change height. Use one spacer per side to add 1/2" or add two spacers per side to gain about 1" in ride height.

94346, 94348



95332, 95338



GM REPLACEMENT BUMP STOP

OEM cone style to replace worn bump stops.



SPC PERFORMANCE

95339

Spring Spacers

21020



FORD RWD F-SERIES TRUCK COIL SPRING BOLT

When installing coil spring spacers on RWD Ford trucks, often times the existing bolts are not long enough. This 3/4" replacement bolt is 10" long, longer than the OE bolt. It will provide plenty of bolt length to allow installation of the nut when reassembling the suspension. This kit provides both the bolt and the nut.

Coil Spring Stabilizers

Proper alignment is impossible unless coil springs are operating at originally designed height.

Service Tips – Sometimes the front stabilizer may rub against the spring well housing. If this situation occurs, the stabilizer must be installed from the inside of the coil springs. Two sizes of short-nosed stabilizers are available: **24701** (a "short-nosed" **24700**); **24751** (a "short-nosed" **24750**). Two stabilizers are recommended per coil spring (no more, no less). Four per pack.

Due to the curvature of some springs, two sizes may be required for the same spring (Example: 24700 on inside of coil, 24750 on outside). When measuring and installing stabilizers, one space should be skipped between coils.

SMALL DIAMETER = .58 INCHES LARGE DIAMETER = .63 INCHES

Stabilizer Heights – Narrow units for small diameter (.58") coil springs.

STBLZR. NO.	HEIGHT ("A")	STBLZR. NO.	HEIGHT ("A")	STBLZR. NO.	HEIGHT ("A")
24640	5/8"	24690	7/8"	24740	1-1/4"
		24790	1-1/2"		

Stabilizer Heights – Regular units for average diameter (.63") coil springs.

STBLZR. NO.	HEIGHT ("A")	STBLZR. NO.	HEIGHT ("A")	STBLZR. NO.	HEIGHT ("A")
24650	5/8"	24751	1-1/4" - Short Nose	24950	2-1/2"
24700	7/8"	24800	1-1/2"	24960	1"
24701	7/8" - Short Nose	24850	1-3/4"	24970	1-1/4"
24750	1-1/4"	24900	2"		

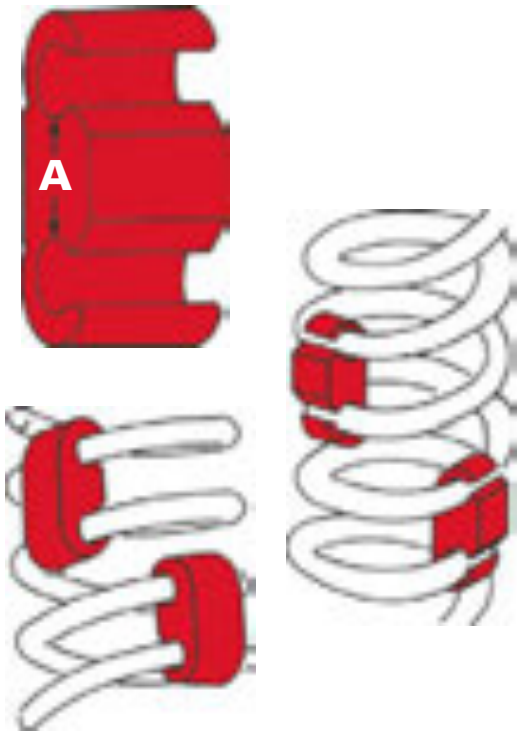

Coil Spring Spacers

PROPER ALIGNMENT REQUIRES CORRECT SPRING HEIGHT

Coil spacers come in various thickness for front and rear coil springs on most cars and trucks. Coil spacers allow shock absorbers to operate through their normal range for longer life and proper response ratios. Spacers restore car trim height for correct front end component relationships, and for improved ride and appearance. They improve stability. When installed in front, car height is raised approximately 2-1/2 to 3 times spacer thickness. Engine weight must be considered. Rear installation on housing raises vehicle approximately 1-1/4 to 1-1/2 times spacer thickness. These spacers are made of aluminum and include one per package.

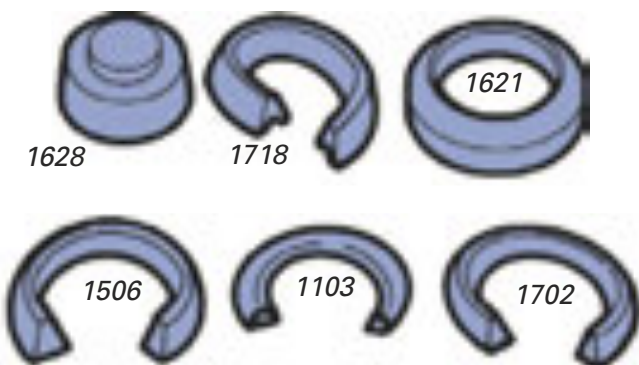

Make/Model	Year	Top or Bottom	Front					Rear		
			3/8"	1/2"	5/8"	3/4"	1"	1/2"	1"	1-1/2"
AMC										
Ambassador	67-74	B						1621	1622	1620
	71-74	T	1502	1503	1504	1505	1506			
American	64-69	T					2012	2013		
Eagle	80-87	T	1502	1503	1504	1505	1506			
Gremlin/Spirit	71-83	T	1502	1503	1504	1505	1506			
Hornet/Concord	72-83	T	1502	1503	1504	1505	1506			
Javelin	68-70	T					2012	2013		
	71-74	T	1502	1503	1504	1505	1506			
Matador	67-78	B	1502	1503	1504	1505	1506			
	72-78	B						1621	1622	1620
Pacer	75-80	B	1702	1703	1704	1705	1706			

Make/Model	Year	Top or Bottom	Front					Rear		
			3/8"	1/2"	5/8"	3/4"	1"	1/2"	1"	1-1/2"
BUICK										
Apollo	73-74	B	1102	1103	1104	1105	1106			
	75	B	1702	1703	1704	1705	1706			
Centurion	71-73	B	1702	1703	1704	1705	1706			
	71-73	T or B						1621	1622	1620
Century RWD	73-76	T or B						1621	1622	1620
	73-81	B	1702	1703	1704	1705	1706			
	77-81	T or B						1621	1627	1628
Century FWD	82-96	B	1102	1103	1104	1105	1106			
	82-96	T						1621	1627	1628

Spring Spacers

Coil Spring Spacers Cars/Vans

Make/Model	Year	Top or Bottom	Front					Rear			Make/Model	Year	Top or Bottom	Front					Rear		
			3/8"	1/2"	5/8"	3/4"	1"	1/2"	1"	1-1/2"				3/8"	1/2"	5/8"	3/4"	1"	1/2"	1"	1-1/2"
BUICK (cont.)									CHEVROLET												
Electra/	39-64	B						1602	1603	Beretta	82-94	B	1303						1621	1627	1628
LeSabre	39-84	B	1702	1703	1704	1705	1706			Camaro	67-69	B	1102	1103	1104	1105	1106				
	54-64	T	2006	2007							70-92	B	1702	1703	1704	1705	1706				
	65-76	T or B						1621	1622	1620	82-97	B						1621	1627	1628	
	77-84	T or B						1621	1627	1628	Cavalier	82-94	B					1621	1627	1628	
Station	79-89	T or B						1621	1627	1628		83-94	B	1303							
Wagon Only	84-94	B						2008	2009-3/4		Celebrity	82-90	B	1102	1103	1104	1105	1106			
Special	64-66	B						1602	1603			82-90	T					1621	1627	1628	
Skyhawk/	64-72	B	1102	1103	1104	1105	1106			Chevelle/	64-66	B						1602	1603		
Somerset	67-72	T or B						1621	1622	1620	Malibu	64-72	B	1102	1103	1104	1105	1106			
	75-79	B	1702	1703	1704	1705	1706				67-76	T or B	1702	1703	1704	1705	1706	1621	1622	1620	
	80-85	B	1102	1103	1104	1105	1106				73-83	B	1702	1703	1704	1705	1706				
	80-85	T						1621	1627	1628	77-83	T or B						1621	1627	1628	
	86-90	B		1303				1621	1627	1628	Chevette	76-87	B	1303				1103	1106		
	91-92	B		1303				1621				76-87	T					2013			
Regal RWD	73-76	T or B						1621	1622	1620	Belair/	55-57	B	1102	1103	1104	1105	1106			
	73-87	B	1702	1703	1704	1705	1706				Caprice/	58-64	T or B	1502	1503	1504	1505	1506	1503	1506	
	77-87	T or B						1621	1627	1628	Chevrolet/	65-70	B	1512	1513	1514	1515	1516			
Riviera	79-85	T						2008	2009-3/4		Impala	65-70	T					1703	1706		
Roadmaster	91-96	B	1702	1703	1704	1705	1706					71-76	T or B				1621	1622	1620		
	91-96	T						1621	1627	1628		71-96	B	1702	1703	1704	1705	1706			
Skyhawk RWD	75-80	B	1102	1103	1104	1105	1106					77-96	T or B					1621	1627	1628	
	75-80	B						1621	1627	1628	Chevy II/	62-67	T	1502	1503	1504	1505	1506			
Skyhawk FWD	82-89	T						1621	1627	1628	Nova RWD	68-74	B	1102	1103	1104	1105	1106			
	83-88	B		1303								75-79	B	1702	1703	1704	1705	1706			
Skyhawk RWD	64-66	B						1601	1602	1603	Citation	80-85	B	1102	1103	1104	1105	1106			
	64-72	B	1102	1103	1104	1105	1106					80-85	T					1621	1622	1620	
	67-72	T or B						1621	1622	1620	Corsica	87-94	B					1621	1627	1628	
	75-79	B	1702	1703	1704	1705	1706					87-96	B	1303							
Skyhawk FWD	80-85	B	1102	1103	1104	1105	1106					95-96	T					2008	2009-3/4		
	80-94	T						1621	1627	1628	Corvette	63-82	B	1702	1703	1704	1705	1706			
	86-96	B		1303							Laguna	74-76	B	1702	1703	1704	1705	1706			
	95-96	T						2008	2009-3/4			74-76	T or B					1621	1622	1620	
Special RWD	64-66	B						1602	1603		Monte Carlo	70-72	B	1102	1103	1104	1105	1106			
	64-69	B	1102	1103	1104	1105	1106					70-76	T or B					1621	1622	1620	
CADILLAC									CHRYSLER												
Allante	87-88	B	1702	1703	1704	1705	1706			Laser	85-87	B						2012-3/4	2013		
Brougham	79-92	B	1702	1703	1704	1705	1706			LeBaron/GTS	82-94	B						2012-3/4	2013		
	79-92	T or B						1621	1627	1628	New Yorker	83-93	B					2012-3/4	2013		
Calais	65-76	B	1702	1703	1704	1705	1706			E Class	83-93	B						2012-3/4/2013			
	65-76	T						1621	1622	1620	DODGE										
Cimarron	82-86	B						1621	1627	1628	400	82-84	B					2012-3/4	2013		
	83-86	B		1303							600	83-88	B					2012-3/4	2013		
Deville RWD	54-71	T	2006	2007							Aries	81-89	B					2012-3/4	2013		
	64-76	T or B						1621	1622	1620	Colt	81-86	T					1103	1106		
	65-84	B	1702	1703	1704	1705	1706					87-90	B					1303			
	77-84	T or B						1621	1627	1628	Daytona	84-93	B					2012-3/4	2013		
Deville FWD	85-93	B						2008	2009-3/4		Dynasty	88-93	B					2012-3/4	2013		
Eldorado	74-78	T or B						1621	1627	1628	Lancer	85-89	B					2012-3/4	2013		
	79-85	B						2008	2009-3/4		Shadow	87-94	T					2012-3/4	2013		
Fleetwood	54-71	T	2006	2007							Spirit	89-95	T					2012-3/4	2013		
RWD	65-76	T or B						1621	1622	1620											
	65-96	B	1702	1703	1704	1705	1706														
	77-96	T or B						1621	1627	1628											
Fltwood FWD	86-92	B						2008	2009-3/4												
Seville	76-79	B	1702	1703	1704	1705	1706	2008	2009-3/4												



Applications
Parts
Heavy Duty
Racing/Off Road
Tools
Accessories
Brake & CV
Gear/Index

Spring Spacers

Coil Spring Spacers Cars/Vans

Make/Model	Year	Top or Bottom	Front					Rear		
			3/8"	1/2"	5/8"	3/4"	1"	1/2"	1"	1-1/2"
FORD										
Crown Vic./ LTD	49-78	T	2006	2007						
	49-97	B	1702	1703	1704	1705	1706			
	65-78	B						1614	1615	1616
	79-03	T or B						1621	1627	1628
	98-03	B	1903		1905	1906				
Escort/EXP	81-86	B	1303					1303		
	87-90	B	1102	1103	1104	1105	1106			
	91-96	T						1615	1616	
Fairlane	66-70	T			2012	2013				
Fairmont	78-83	B	1502	1503	1504	1505	1506			
	78-83	T						2007		
Falcon	60-70	T			2012	2013				
Granada	75-80	T			2012	2013				
	81-83	B	1502	1503	1504	1505	1506			
	81-83	T						2007		
LTD II	82-86	B	1502	1503	1504	1505	1506			
	82-86	T						2007		
Maverick	69-77	T			2012	2013				
Mustang/ Mustang II	65-73	T			2012	2013				
	74-96	B	1102	1103	1104	1105	1106			
	80-96	T						2007		
Pinto	71-80	B	1102	1103	1104	1105	1106			
Taurus/Wagon	86-95	B	1702	1703	1704	1705	1706			
Tempo	84-94	B	1502	1503	1504	1505	1506	1703	1706	
Thunderbird	61-71	T	2008		2009					
	67-79	B	1702	1703	1704	1705	1706			
	80-88	T						2007		
	80-97	B	1502	1503	1504	1505	1506			
	89-97	T						2008	2009-3/4	
Torino	68-71	T			2012	2013				
	72-79	T or B						1614	1615	1616
	72-81	B	1702	1703	1704	1705	1706			
	80-81	T or B						1621	1627	1628

LINCOLN										
Continental	49-60	T	2008		2009					
	61-78	T	2006	2007				1614	1615	1616
	70-79	B						1621	1627	1628
	80-81	T or B						1621	1627	1628
	82-84	B	1502	1503	1504	1505	1506	1621	1627	1628
	82-84	T						2007		
Lincoln	82-84	B	1702	1703	1704	1705	1706			
	82-84	T or B						1621	1627	1628
Town Car	80-93	B	1702	1703	1704	1705	1706			
	80-93	T or B						1621	1627	1628

Make/Model	Year	Top or Bottom	Front					Rear		
			3/8"	1/2"	5/8"	3/4"	1"	1/2"	1"	1-1/2"
MERCURY										
Bobcat	75-80	B	1102	1103	1104	1105	1106			
Capri	79-86	B	1102	1103	1104	1105	1106			
	79-86	T							2007	
Comet	60-77	T				2012	2013			
Cougar	67-73	T				2012	2013			
	74-79	B	1702	1703	1704	1705	1706	1614	1615	1616
	80-97	B	1502	1503	1504	1505	1506			
	80-88	T						2007		
	89-97	T						2008	2009-3/4	
Grand Marquis	79-97	B	1702	1703	1704	1705	1706			
	79-00	T or B						1621	1627	1628
	98-00	B		1903	1905	1906				
Lynx/LN7	82-84	B		1303						
	82-87	T						1615	1616	
Marquis	82-86	B	1502	1503	1504	1505	1506			
	80-86	T						2007		
Mercury	52-78	T	2006	2007						
	52-82	B	1702	1703	1704	1705	1706			
	56-78	B						1614	1615	1616
	79-82	T or B						1621	1627	1628
Monarch	75-80	T		2011	2012	2013				
Montego	68-71	T			2012	2013				
	72-76	B	1702	1703	1704	1705	1706	1614	1615	1616
Sable	86-95	B	1702	1703	1704	1705	1706			
Topaz	84-90	B	1502	1503	1504	1505	1506	1703	1706	
Zephyr	78-83	B	1502	1503	1504	1505	1506			
	78-83	T						2007		

OLDSMOBILE										
88	55-85	B	1702	1703	1704	1705	1706			
	61-63	T						1601	1602	1603
	64-76	T or B						1621	1622	1620
	65-85	T		2008	2009					
	77-85	T or B						1621	1627	1628
	86-96	B						2008	2009-3/4	
98	55-84	B	1702	1703	1704	1705	1706			
	64-76	T or B						1621	1622	1620
	65-84	T		2008	2009					
	77-84	T or B						1621	1627	1628
	85-97	B						2008	2009-3/4	
Achieva	92-94	B						1621		
Calais	85-91	B		1303				1621	1627	1628
Custom	74-92	B	1702	1703	1704	1705	1706			
Cruiser	74-92	T or B						1621	1627	1628
Cutlass/ F-85 RWD	61-66	B						1601	1602	1603
	64-72	B	1102	1103	1104	1105	1106			
	67-88	T or B						1621	1627	1628
	73-88	B	1702	1703	1704	1705	1706			
Cutlass Cierra	82-96	B	1102	1103	1104	1105	1106			
	82-96	T						1621	1627	1628
Firenza	82-88	B						1621	1627	1628
	83-88	B		1303						
Omega	72-74	B	1102	1103	1104	1105	1106			
	75-79	B	1702	1703	1704	1705	1706			
	80-84	B	1102	1103	1104	1105	1106			
	80-84	T						1621	1627	1628
Starfire	75-81	T	1102	1103	1104	1105	1106			
	75-81	B						1621	1627	1628
Toronado	71-78	T or B						1621	1622	1620
	78-85	T						2008	2009-3/4	

Applications

Parts

Heavy Duty

Racing/Off Road

Tools

Accessories

Brake & CV

Gear/Index

Spring Spacers

Coil Spring Spacers Cars/Vans

Make/Model	Year	Top or Bottom	Front					Rear			Make/Model	Year	Top or Bottom	Front					Rear		
			3/8"	1/2"	5/8"	3/4"	1"	1/2"	1"	1-1/2"				3/8"	1/2"	5/8"	3/4"	1"	1/2"	1"	1-1/2"
PLYMOUTH										VANS											
Acclaim	89-95	B						2012-3/4	2013		CHEVROLET										
Champ	79-82	T						1103	1106		Astro	85-89	B	1702	1703	1704	1705	1706			
Reliant	81-90	B									Except AWD	90-03	B		1903		1905	1906			
Sundance	87-94	B									G10, 20,30	68-03	B	1702	1703	1704	1705	1706			
PONTIAC																					
6000	82-91	B	1102	1103	1104	1105	1106				P30	68-99	B	1702	1703	1704	1705	1706			
	82-91	T						1621	1627	1628	Ventura	97-03	T	1502	1503	1504	1505	1506			
Astre	75-81	B	1102	1103	1104	1105	1106	1621	1627	1628		97-03	B						1621	1627	1628
Bonneville	58-64	T or B						1601	1602	1603	DODGE										
RWD	58-81	T	2006	2007							B100,150,	71-01	B		1903		1905	1906			
	58-86	B	1702	1703	1704	1705	1706				200, 250, 300, 350										
	67-76	T or B						1621	1622	1620	FORD										
	77-86	T or B						1621	1627	1628	Aerostar	88-97	B	1702	1703	1704	1705	1706		1619	
	87-97	B						2008	2009-3/4		Aerostar AWD	91-96	B	1502	1503	1504	1505	1506		1619	
Fiero	84-88	B		1303				1103	1106		E-100	69-74	T		1714		1716	1718			
Firebird	67-69	B	1102	1103	1104	1105	1106				E-150,200,	69-03	T		1724		1726	1728			
	70-92	B	1702	1703	1704	1705	1706				250, 300,350										
	82-96	B						1621	1627	1628	E-150,200,	75-91	B		1617		1618	1619			
Grand Am	85-97	B		1303				1621	1627	1628	250,300,350										
Grand Prix	62-87	B	1702	1703	1704	1705	1706				GMC										
	67-87	T or B						1621	1627	1628	Safari	85-89	B	1702	1703	1704	1705	1706			
Grand	77-89	B	1702	1703	1704	1705	1706				Except AWD	90-03	B		1903		1905	1906			
Safari SW	77-89	T or B						1621	1627	1628	G15,25,35	68-02	B	1702	1703	1704	1705	1706			
J 2000	82-85	B						1621	1627	1628	Savana	96-02	T	1502	1503	1504	1505	1506			
	83-85	B		1303								96-02	B						1621	1627	1628
Lemans RWD	64-66	B						1601	1602	1603											
	64-72	B	1102	1103	1104	1105	1106														
	67-76	T or B						1621	1622	1620											
	73-81	B	1702	1703	1704	1705	1706														
	77-81	T or B						1621	1627	1628											
Lemans FWD	88-93	B		1303																	
Phoenix	80-84	B	1702	1703	1704	1705	1706														
	80-84	T						1621	1627	1628											
Sunbird RWD	75-81	B	1102	1103	1104	1105	1106	1621	1627	1628											
Sunbird FWD	82-94	B		1303				1621	1627	1628											
T 1000	81-87	B		1303				1103	1106												
	81-87	T								2012-3/4	2013-1										
Ventura	71-74	B	1102	1103	1104	1105	1106														
	75-79	B	1702	1703	1704	1705	1706														



Spring Spacers

Coil Spring Spacers Trucks/SUVs

Make/Model	Year	Top or Bottom	Front					Rear			Make/Model	Year	Top or Bottom	Front					Rear		
			3/8"	1/2"	5/8"	3/4"	1"	1/2"	1"	1-1/2"				3/8"	1/2"	5/8"	3/4"	1"	1/2"	1"	1-1/2"
4WD									RWD												
CHEVROLET									CHEVROLET												
Suburban 1500	02-04	B						1621	1627	1628	El Camino	64-66	B						1602	1603	
Tahoe	02-04	B						1621	1627	1628		64-72	B	1102	1103	1104	1105	1106			
Trailblazer	02-07	B						1621	1627	1628		67-77	T or B						1621	1622	1620
FORD																					
Bronco	66-79	T		1714		1716	1718					73-87	B	1702	1703	1704	1705	1706			
	80-88	B					1619					77-87	T or B						1621	1627	1628
	80-96	T		1724		1726	1728				C10, 20, 30	60-71	T or B						1602	1603	
	*89-96	B		1617		1618	1619					63-87	B	1702	1703	1704	1705	1706			
Bronco II	83-89	B				1618	1619				C1500, 2500, Except HD	88-06	B		1903		1905	1906			
	90	B		1817		1818	1819					88-06	T		2008		2009				
Explorer	90-94	B		1817		1818	1819				C3500 Except HD	88-01	B		1903		1905	1906			
Ranger	83-89	B				1618	1619				S10	82-03	B	1702	1703	1704	1705	1706			
	90-97	B		1817		1818	1819				Suburban	64-91	B	1702	1703	1704	1705	1706			
F-100, 150	66-79	B				1711-1"	1712-1.5"					92-04	B		1903		1905	1906			
	66-79	T		1714		1716	1718				Tahoe	92-04	B		1903		1905	1906			
	80-88	B					1619					02-04	B						1621	1627	1628
	80-96	T		1724		1726	1728				Trailblazer	02-07	B						1621	1627	1628
	*89-96	B		1617		1618	1619				DODGE										
	04-09	T	1703	1704	1705	1706					D-50	79-81	B	1102	1103	1104	1105	1106			
GMC																					
Envoy	02-07	B						1621	1627	1628	Dakota	86-03	B	1702	1703	1704	1705	1706			
Yukon/ Yukon XL	02-04	B						1621	1627	1628	D-100,150,200 250, 300, 350	71-93	B		1903		1905	1906			
JEEP																					
Cherokee XJ/ Wagoneer XJ	84-01	B	1702	1703	1704	1705	1706				Ramcharger	75-81	B		1903		1905	1906			
Grand Cher.	93-98	B	1702	1703	1704	1705	1706	1703	1706		Ram 50	82-90	B	1102	1103	1104	1105	1106			
Wrangler TJ	97-04	B	1702	1703	1704	1705	1706				R1500, 2500, 3500	94-07		1903		1905	1906				
									FORD (see page 96 for longer coil spring bolt)												
									Courier												
									73-83												
									B												
									1303												
									Excursion												
									00-04												
									B												
									1618												
									1619												
									Excursion												
									00-04												
									T												
									1724												
									1726												
									1728												
									Expedition												
									97-02												
									B												
									1702												
									1703												
									1704												
									1705												
									1706												
									03-04												
									T												
									1702												
									1703												
									1704												
									1705												
									1706												
									F-100, 250												
									65-70												
									T												
									1702												
									1703												
									1704												
									1705												
									1706												
									F-100, 150, 250, 350												
									65-88												
									B												
									1617												
									1618												
									1619												
									*89-96												
									B												
									1618												
									1619												
									F-100, 150, 250 under												
									80-96												
									T												
									1724												
									1726												
									1728												
									6900 GVW												
									97-03												
									B												
									1702												
									1703												
									1704												
									1705												
									1706												
									F-250, 350 over												
									80-04												
									T												
									1724												
									1726												
									1728												
									98-04												
									B												
									1618												
									1619												
									6900 GVW												
									Ranchero												
									68-71												
									T												
									2012												
									2013												
									72-79												
									B												
									1702												
									1703												
									1704												
									1705												
									1706												
									1614												
									1615												
									1616												
									Ranger												
									82-89												
									B												
									1618												
									1619												
									90-97												
									B												
									1817												
									1818												
									1819												
									98-04												
									B												
									1702												
									1703												
									1704												
									1705												
									1706												
									GMC												
									C15, 25, 35												
									60-71												
									T or B												
									1602												
									1603												
									C1500, 2500, 3500												
									63-87												
									B												
									1702												
									1703												
									1704												
									1705												
									1706												
									88-06												
									B												
									1903												
									1905												
									1906												
									Except HD												
									88-06												
									T												
									2008												
									2009												
									Envoy												
									02-07												
									B												
									1621												
									1627												
									1628												
									S-15												
									82-03												
									B												
									1702												
									1703												
									1704												
									1705												
									1706												
									Sprint/ Caballero												
									71-72												
									B												
									1102												
									1103												
									1104												
									1105												
									1106												
									71-77												
									T or B												
									1621												
									1622												
									1620												
									73-87												
									B												
									1702												
									1703												
									1704												
									1705												
									1706												
									78-87												
									T or B												
									1621												
									1627												
									1628												
									Yukon												
									02-04												
									B												
									1903												
									1905												
									1906												
									02-04												
									B												
									1621												
									1627												
									1628												
									Yukon XL												
									00-04												
									B												
									1903												
									1905												
									1906												

**Measure length of stud above nut holding in spring. Add 1/8" to above measurement. That is the maximum thickness of spacer recommended without changing bolt. Discard plastic spring silencer.*

Applications

Parts

Heavy Duty

Racing/Off Road

Tools

Accessories

Brake & CV

Gear/Index

HEAVY DUTY



36000

Tandem Alignment Set A great starter set!

These alignment angle shims are now available in a heavy-duty metal box to help you organize all of your shims. Packaged with a large variety of shims (listed below) and an organization chart inside the lid to make reordering and organization of shims quick and easy.



Part No.	Application	Qty
35001	Kenworth Airglide space 1/32"	6
35002	Kenworth Airglide space 1/16"	6
35003	Kenworth Airglide space 1/8"	6
35004	Kenworth Airglide space 1/4"	6
35005	Kenworth Airglide space 1/2"	6
35006	Kenworth Airglide space 3/4"	6
35007	Kenworth Airglide space 1"	6
35010	Peterbilt Air Leaf Shim 1/32"	2
35011	Peterbilt Air Leaf Shim 1/16"	4
35012	Peterbilt Air Leaf Shim 1/8"	6
35020	Freightliner FAS I Air Ride 1/32"	2
35021	Freightliner FAS I Air Ride 1/16"	4
35022	Freightliner FAS I Air Ride 1/8"	6
35030	Volvo/White 4-Spring Susp 1/32"	2

Part No.	Application	Qty
35031	Volvo/White 4-Spring Susp 1/16"	4
35033	Volvo/White 4-Spring Susp 1/8"	6
35040	Navistar IHC Torque Arm 1/32"	2
35041	Navistar IHC Torque Arm 1/16"	4
35042	Navistar IHC Torque Arm 1/8"	6
35060	Freightliner Airliner Susp 1/32"	2
35061	Freightliner Airliner Susp 1/16"	4
35062	Freightliner Airliner Susp 1/32"	6
35070	Freightliner Air Glide Susp 1/32"	2
35071	Freightliner Air Glide Susp 1/16"	4
35072	Freightliner Air Glide Susp 1/8"	6
36010	Peter/KW Flex-Air Torque Arm 1/32"	2
36011	Peter/KW Flex-Air Torque Arm 1/16"	4
36012	Peter/KW Flex-Air Torque Arm 1/8"	2

Tandem Truck Shims

These over-the-road heavy duty adjusters are a fast and accurate means to align front or rear axles of most popular tandem trailers and trucks. You, the alignment technician, now have reliable means to complete total heavy duty truck alignments.

KENWORTH AIR GLIDE SPACERS FOR "EIGHT BAGGERS"



Part No.	Thickness	Qty	Part No.	Thickness	Qty
35001	1/32"	6	35005	1/2"	6
35002	1/16"	6	35006	3/4"	6
35003	1/8"	6	35007	1"	6
35004	1/4"	6			

FREIGHTLINER ADJUSTING SHIM

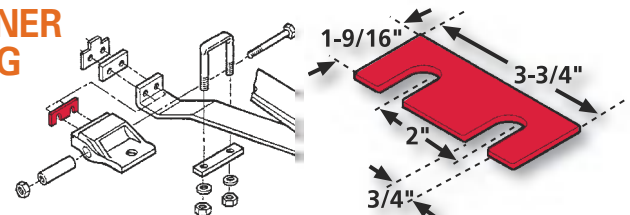

These shims adjust thrust angle and toe by placing it between the spring hanger and the spring.

Part No.	Thickness	Qty
35020	1/32"	6
35021	1/16"	6
35022	1/8"	6

PETERBILT AIR LEAF THRUST ANGLE SHIM

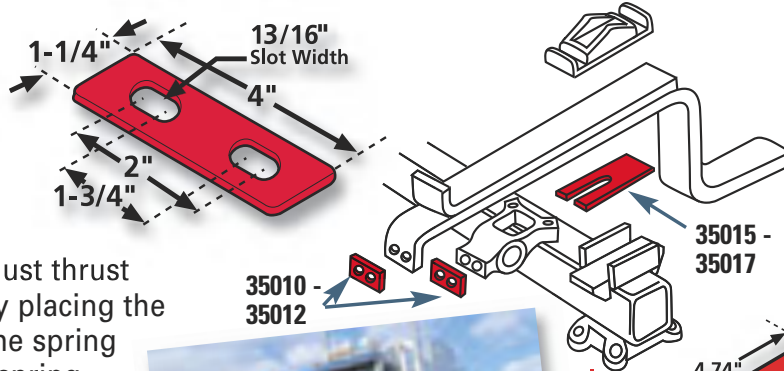

These shims adjust thrust angle and toe by placing the shim between the spring hanger and the spring.

Part No.	Thickness	Qty
35010	1/32"	6
35011	1/16"	6
35012	1/8"	6



PETERBILT AIR LEAF PINION ANGLE SHIM

Adjust pinion angle on the drive axle of your Peterbilt Low Air Leaf with 'Z-Springs' using these shims. The OE shim is aluminum and does not last under load; the SPC Zinc Shim is built to last.

Part No.	Thickness	Qty
35015	1/32"	2
35016	1/16"	2
35017	1/8"	2

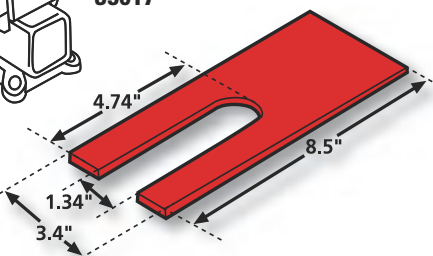

We have parts and tools for Fleet Vehicles - check out our application charts (pages 7 - 45).

Heavy Duty Tandem Truck Shims

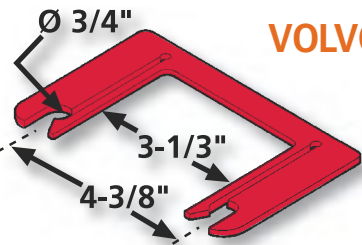

VOLVO/WHITE TANDEM SHIM

Part No.	Thickness	Qty
35030	1/32"	6
35031	1/16"	6
35032	1/8"	6

These shims adjust thrust angle and toe by placing it between the spring hanger and the spring.

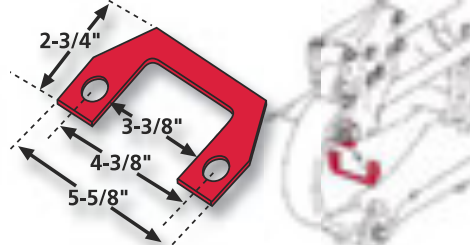

PETERBILT/KENWORTH FLEX AIR SUSPENSION SHIMS

Part No.	Thickness	Qty
36010	1/32"	6
36011	1/16"	6
36012	1/8"	6

By shimming the torque arms these shims adjust toe and thrust angle.

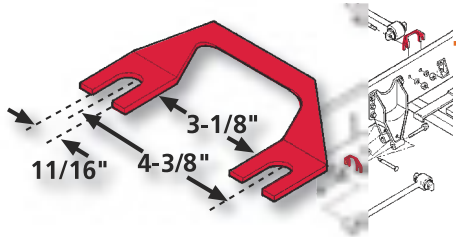

I.H.C./NAVISTAR TORQUE ARM SHIM

Part No.	Thickness	Qty
35040	1/32"	6
35041	1/16"	6
35042	1/8"	6

Will change thrust and toe when installed between the torque arm and the spring hanger. On Navistar they will also center the axle with the frame rails when used on the lateral link.

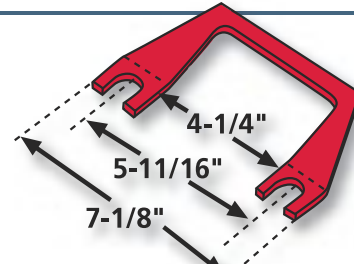

NAVISTAR SHIM FOR "CORPORATE" 6x4 AIR SUSPENSION

Part No.	Thickness	Qty
36020	1/32"	6
36021	1/16"	6
36022	1/8"	6

When used on the lateral link these shims will center the axle with the frame rails. Also will adjust thrust angle and toe by placing the shim between the spring hanger and the spring.

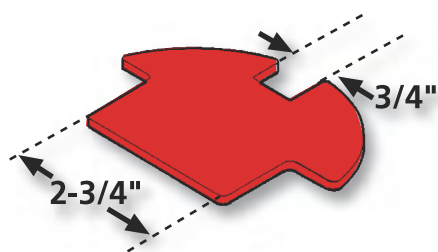

WILSON TANDEM SHIM FOR HUTCHINS SUSPENSION

Part No.	Thickness	Qty
35050	1/32"	6
35051	1/16"	6
35052	1/8"	6

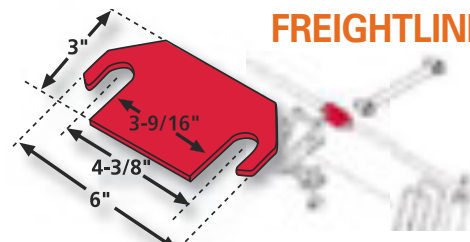

FREIGHTLINER SHIMS FOR FAS II SUSPENSIONS

Part No.	Thickness	Qty
36031	1/16"	6
36032	1/8"	6

Will change thrust and toe when installed between the torque arm and the spring hanger. They will also center the axle with the frame rails when used on the lateral link.

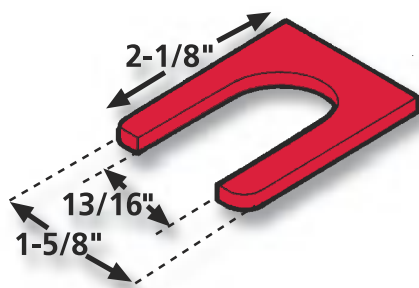

SINGLE SLOT TANDEM TRUCK SHIMS

USE FOR FREIGHTLINER "AIRLINER" K77936 SUSPENSION

Part No.	Thickness	Qty
35060	1/32"	6
35061	1/16"	6
35062	1/8"	6

These universal shims are installed at the ends of torque rods to change toe and/or thrust angles on **Freightliner**, **Hendrickson** and **Navistar** heavy duty tandem trucks and trailers.

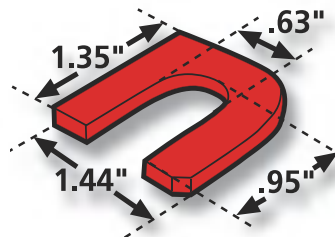

VANHOOL LOWER CONTROL ARM & BOGEY AXLE SHIM

Part No.	Thickness	Qty
36040	1/32"	6
36041	1/16"	6
36042	1/8"	6

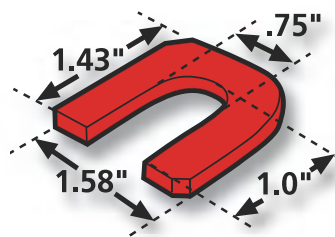

VANHOOL UPPER CONTROL ARM & DRIVE AXLE SHIM

Part No.	Thickness	Qty
36050	1/32"	6
36051	1/16"	6
36052	1/8"	6

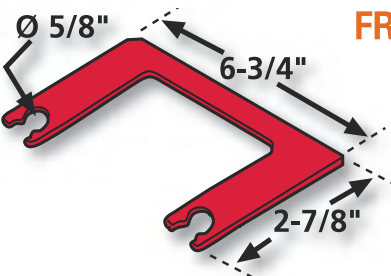

FREIGHTLINER SHIMS FOR AIR GLIDE SUSPENSION

Part No.	Thickness	Qty
35070	1/32"	6
35071	1/16"	6
35072	1/8"	6

These shims adjust thrust angle and toe by placing the shim between the spring hanger and the spring.

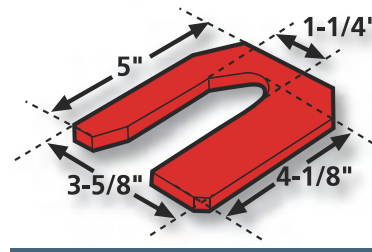

PREVOST CASTER SHIM

Part No.	Thickness	Qty
36060	1/32"	6
36061	1/16"	6
36062	1/8"	6

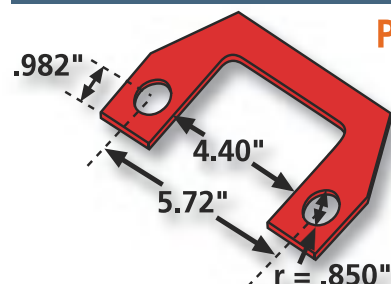

PETERBILT & KENWORTH THRUST ANGLE SHIMS

Part No.	Thickness	Qty
36001	1/32"	6
36002	1/16"	6
36003	1/8"	6

These shims are for the new Peterbilt and Kenworth "Low Air Suspensions".

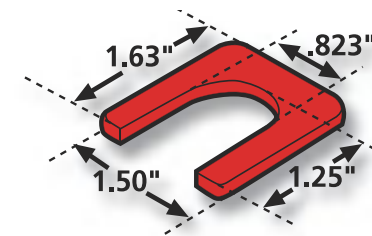

PREVOST CASTER SHIM

Part No.	Thickness	Qty
36070	1/32"	6
36071	1/16"	6
36072	1/8"	6

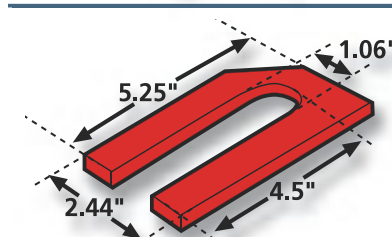

PREVOST X & XL SHIM

Part No.	Thickness	Qty
36090	1/32"	6
36091	1/16"	6
36092	1/8"	6

Heavy Duty Truck Axle Shims

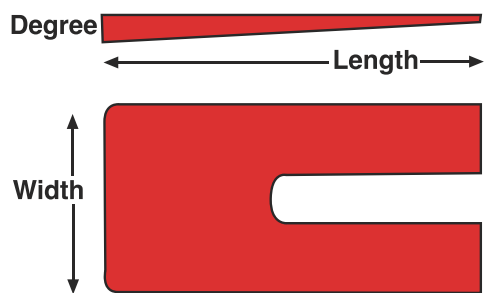

	COST	COMPRESSION STRENGTH	HARDNESS
ALUMINUM ALLOY	\$\$	★★★	★★★
ZINC ALLOY	\$\$\$	★★★★	★★★★★
MANGANESE BRONZE ALLOY	\$\$\$\$\$	★★★★★	★★★★★

Ordering one Part Number supplies **SIX SHIMS** in a box. When placing order spring pad length and width is needed.

We now have Aluminum, ZINC and Manganese Bronze Shims Available

ALUMINUM ALLOY	ZINC ALLOY	MANGANESE BRONZE	SPRING WIDTH	DEGREE	SPR. PAD LENGTH	QTY/BOX
10405	10403	10404	2-1/2"	1/2°	5"	6
10412	10413	10414	2-1/2"	1°	5"	6
10422	10423	10424	2-1/2"	1-1/2°	5"	6
10432	10433	10434	2-1/2"	2°	5"	6
10442	10443	10444	2-1/2"	2-1/2°	5"	6
10452	10453	10454	2-1/2"	3°	5"	6
10462	10463	10464	2-1/2"	3-1/2°	5"	6
10472	10473	10474	2-1/2"	4°	5"	6
10505	10503	10504	3"	1/2°	6"	6
10512	10513	10514	3"	1°	6"	6
10522	10523	10524	3"	1-1/2°	6"	6
10532	10533	10534	3"	2°	6"	6
10542	10543	10544	3"	2-1/2°	6"	6
10552	10553	10554	3"	3°	6"	6
10562	10563	10564	3"	3-1/2°	6"	6
10572	10573	10574	3"	4°	6"	6
10605	10603	10604	3-1/2"	1/2°	6-1/4"	6
10612	10613	10614	3-1/2"	1°	6-1/4"	6
10622	10623	10624	3-1/2"	1-1/2°	6-1/4"	6
10632	10633	10634	3-1/2"	2°	6-1/4"	6
10642	10643	10644	3-1/2"	2-1/2°	6-1/4"	6
10652	10653	10654	3-1/2"	3°	6-1/4"	6
10662	10663	10664	3-1/2"	3-1/2°	6-1/4"	6
10672	10673	10674	3-1/2"	4°	6-1/4"	6
10705	10703	10704	4"	1/2°	6-1/2"	6
10712	10713	10714	4"	1°	6-1/2"	6
10722	10723	10724	4"	1-1/2°	6-1/2"	6
10732	10733	10734	4"	2°	6-1/2"	6
10742	10743	10744	4"	2-1/2°	6-1/2"	6
10752	10753	10754	4"	3°	6-1/2"	6
10762	10763	10764	4"	3-1/2°	6-1/2"	6
10772	10773	10774	4"	4°	6-1/2"	6
10782	10783	--	4"	5°	6-1/2"	6

Specialty Products carries Truck Axle Caster Shims in three different alloys, giving the technician the opportunity to match price point and mechanical requirements to meet their customer's needs.

ALUMINUM ALLOY HD SHIMS

These economical over-the-road heavy duty truck axle shims are our lowest cost option. With average compression strength and hardness these shims are available in a large variety of sizes and offer the technician a cost effective means to correct caster on over-the-road trucks and trailers.



ZINC ALLOY HD SHIMS

These over-the-road heavy duty truck axle shims are a fast and accurate means to align front or rear axles of most popular tandem trailers and trucks. Specialty Products' new Zinc Alloy shims offer another level of performance versus our traditional aluminum shims. For a small cost increase versus aluminum, you now have the hardness of our premium manganese bronze shims and a much improved compression strength as compared to aluminum shims.



MANGANESE BRONZE HD SHIMS

These shims are the standard. Top of the line compression strength and hardness means that when you set your alignment - it doesn't change.



NOTE - On all shims - if you are using "Z Blocks" or other axle spacers you need to spread the load to prevent the shim from crushing. Check out SPC's HD Axle Spacer Plate below to solve this common problem.

HD AXLE SPACER PLATE (6)

Spread the load! "Z" Blocks and other axle spacers used by Hendrickson, Freightliner, Kenworth, Mack, Hollis, Sterling, Ford, and others create pressure points that will crush or even break the toughest of caster wedges. Use this HD Wedge Support Plate to spread the load and then use the caster shim of your choice to modify alignment. The 1/8" thick plates come 6 to a pack and are available in three widths. The HD Wedge Support Plate can also be used to dial in ride height from side to side.

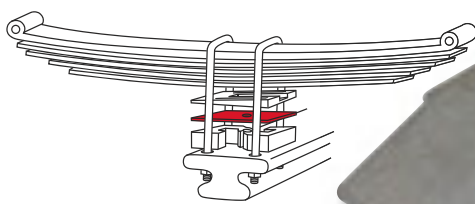

10598
10698
10798

#10598 - 3" Wide • #10698 - 3.5" Wide • #10798 - 4" Wide



Heavy Duty Truck Axle Shims

80199-81099

ZINC TRUCK AXLE SHIMS

These popular heavy-duty axle shims are for vehicles with 1-3/4" to 2" wide leaf springs. **APPLICATIONS:** Any solid axle 2WD or 4WD vehicle.

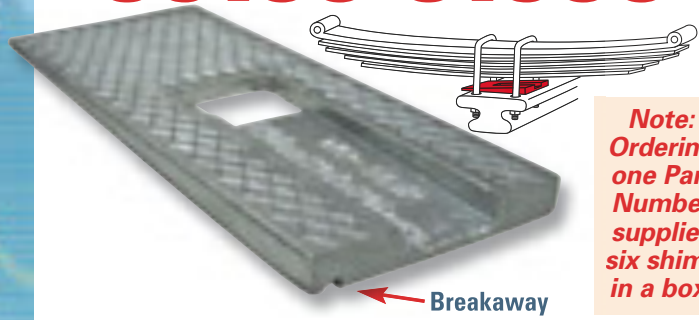

Note:
Ordering one Part Number supplies six shims in a box.

Part No.	Width	Degree Taper	Qty/Box	Part No.	Width	Degree Taper	Qty/Box
80199	1-3/4" - 2"	1/2°	6	80699	1-3/4" - 2"	3°	6
80299	1-3/4" - 2"	1°	6	80799	1-3/4" - 2"	3-1/2°	6
80399	1-3/4" - 2"	1-1/2°	6	80899	1-3/4" - 2"	4°	6
80499	1-3/4" - 2"	2°	6	80999	1-3/4" - 2"	5°	6
80599	1-3/4" - 2"	2-1/2°	6	81099	1-3/4" - 2"	6°	6

89199-89899

UNI-WEDGE SHIMS (HD ZINC ALLOY)

Twice the coverage - half the inventory. Changes caster positive or negative from 1/2° to 4°. **APPLICATIONS:** Any solid axle 2WD or 4WD vehicle.

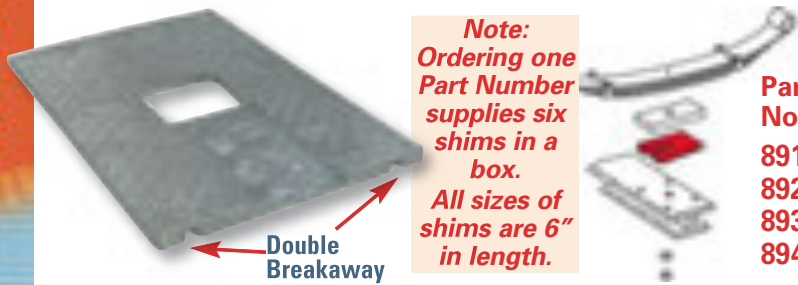

Note:
Ordering one Part Number supplies six shims in a box. All sizes of shims are 6" in length.

Part No.	Width	Degree Taper	Qty/Box	Part No.	Width	Degree Taper	Qty/Box
89199	3" - 3-1/2" - 4"	1/2°	6	89599	3" - 3-1/2" - 4"	2-1/2°	6
89299	3" - 3-1/2" - 4"	1°	6	89699	3" - 3-1/2" - 4"	3°	6
89399	3" - 3-1/2" - 4"	1-1/2°	6	89799	3" - 3-1/2" - 4"	3-1/2°	6
89499	3" - 3-1/2" - 4"	2°	6	89899	3" - 3-1/2" - 4"	4°	6

36080 36085

HENDRICKSON WALKING BEAM SHIMS

These are the OE style shims recommended by Hendrickson. The 36080 offers three adjustments at 0, 3/16" and 3/8". The 36085 gives you four different adjustments of 0, 1/8", 1/4" and 3/8". Each part number includes 2 to a package.

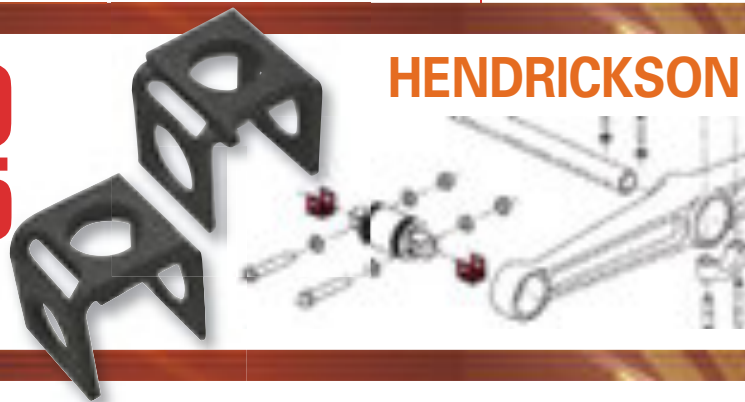

36087

HENDRICKSON HD SHIMS

This shim kit will adjust the thrust angle on Hendrickson's 'walking beam' rear tandem axle suspension. Improve tire wear and handling by adjusting thrust angle from 0" to 3/8" in precise 1/32" increments.

REPLACES these OEM kits-
Euclid Nos: E-9327, E-9328, E-9329 Hendrickson Nos: 50130-000, 50131-000, 50132-000

Adj. Range: 3/8" Required: 1 set per wheel
Includes: 2 (two)-five piece kits

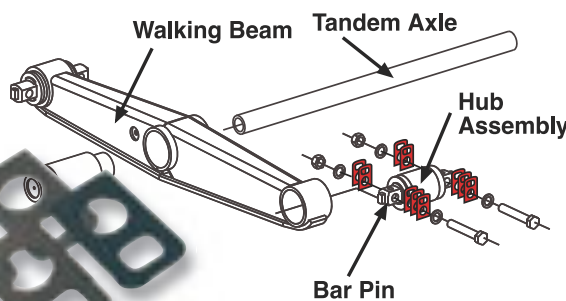

Work smarter - look for this SPC-TV.com icon. This icon means there is a video on the SPC-TV website that shows you how the pros here at SPC Performance install this part.

Tune In • Log On • Earn Now

- Log on to www.spc-tv.com and register - it's easy!
- Watch short videos that show how to install popular parts and our favorite tools

- Learn how to do your job better and faster
- Earn points and get great gear from SPC

Tune into SPC-TV at www.spc-tv.com and start earning points today!



Heavy Duty WHEEL CENTERING PRODUCTS

- Wheel Vibrations?**
- Wheel Hop?**
- Brake Pedal Pulsations?**
- Erratic Tire Wear?**
- Excessive Fuel Consumption?**

If you are experiencing these problems, it may be because your wheels aren't centered on the hub. And if your wheels aren't centered, you will continue to experience these problems. With **Specialty Products' Wheel Centering Products**, you can re-center your wheel, and eliminate all of these problems.

Benefits...

- Increases fuel mileage**
- Increases tire life**
- Decreases tire vibration**
- Cuts rebalancing costs**
- Reduces "wheel-off" condition**
- Reduces tire cupping**

Perfect for...

- Semi Trucks and Trailers*
- Heavy & Medium Duty Trucks*
- Parcel Package Trucks*
- Emergency Vehicles*
- Commercial Buses*
- School Buses*
- Motor Coaches*

Install our wheel centering products on your truck or fleet and start saving money NOW! Simply the BEST solution for tire vibration and erratic wear.

SPC 'EZ ON' Wheel Centering Tool Set

- 32111** OTR Vehicles
22mm
- 32115** Ford F450/F550
Super Duty
14mm
- 32116** Alcoa Wheels
made in
Hungary
22mm

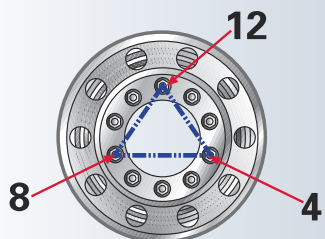

Stop wheel hop and vibrations on hub piloted wheels! Wheel stud hole diameter tolerances can allow wheels to be installed and tightened in an "off center" or clocked position. The 32111 threadless wheel centering tool set (3) fits 22mm studs on Heavy Duty and Over-the-Road Tractors and Trailers. The 32115 is for Ford F450/F550 Super Duty. These tools slide directly over the wheel studs in the 12, 4, and 8 o'clock positions. The wheel is then installed over the tools, the stud nuts added to the exposed studs and tightened. The wheel is now centered precisely. The centering tools are removed and the final stud nuts are added-torquing all nuts to mfg. specifications.

Features

- Threadless Design
- Tapered Nose
- Single Set

Benefits

- Saves Installation Time
- Eases Wheel Mounting
- For Steer, Drive & Trailer Axles

32111
32115
32116 



Our new threadless design allows the installer to quickly and easily center the wheels to the hub. And our tapered design makes it easy to mount the wheel over the hub.



WHEEL CENTERING PRODUCTS

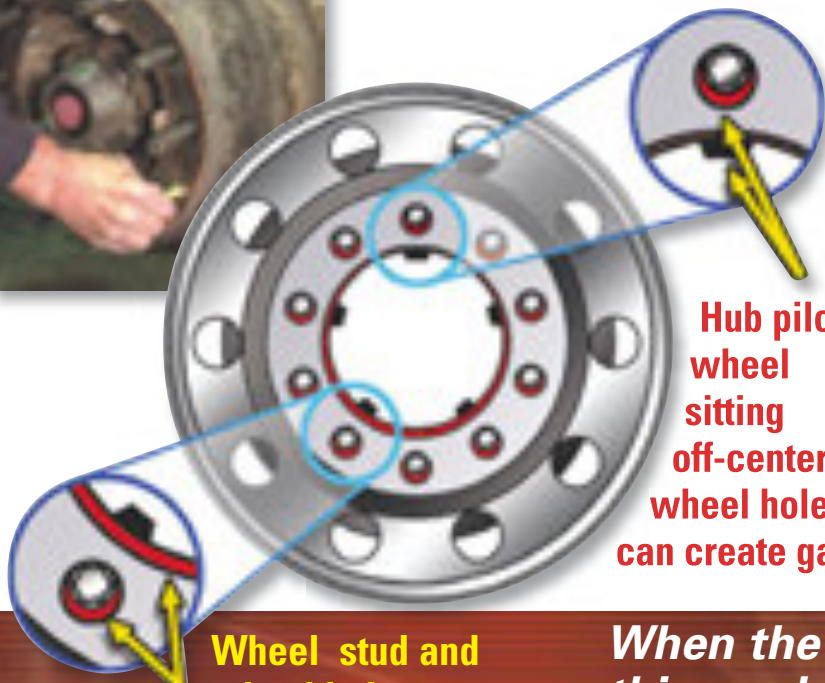

How it works

If your hub piloted wheel is sitting on the hub stud off-center (as shown in the illustration to the left) you need these parts and tools to avoid wheel hop and excess tire wear, and to increase your fuel mileage.

The theory behind the hub pilot is it centers the wheel. The fact is gravity causes the weight of the wheel to rest only on the upper pilots creating a gap in the bottom pilots. Even the smallest gap results in an egg-shaped motion upon rotation. This uneven motion creates rolling resistance which causes tire vibration, increased fuel consumption and erratic tire wear. The bottom line is, you can't balance an egg.

Wheel stud and wheel hole gap can create spaces or gaps between wheel and hub pilot

When the wheel rests on the upper hub pilot this produces a gap at the other pilots resulting in an off-center condition. This causes wheel vibration and erratic tire wear.



SPC 'EZ ON' Wheel & Brake Drum Centering Sleeves

These sets center both steer axle HD wheels and brake drums to minimize wheel vibrations, brake pedal pulsations, and wheel hop. For both Aluminum and Steel steer wheels and a variety of brake drum types.

This threadless sleeve design allows the installer to quickly and easily center wheels and brake drums - a great time saver and affordable!



22mm Steer Wheel - Brake Drum Type	Dimensions	Aluminum Part No.	Steel Part No.	Qty.
Gunite 3573X, 3596X, 3597X, 3598X, 3686X, 3687X, 3710X, 3721AX, 3726X, 3758X, 3774X, 3800X Webb 61528B, 65548B Arvin Meritor 53-123448-002, 53-123567-002, 53-123568-002	1.25" hole/.5" depth	32120	32124	6
Gunite 9000X, 9001X, 9035X Motor Wheel Centrifuse 89870BK, 90089BK, 90174BK Arvin Meritor 53-123512-002, 53-123542-002	1.25" hole/.25" to .3125" depth	32121	32122	6
Conmet 10009920	1.34" to 1.37" hole /.5" depth	32125	32126	6
Conmet 107164, 107453, 107507, 107862, 10001781, 10001783, 10005331, 10005332	1.28" hole /.5" depth	32127	32128	6
Gunite 3596BX, 3753AX, 3754AX	1.00" hole/.5" depth	32123		6
NEW - 19.5mm Steer Wheel - Brake Drum Type				
'TAG' axles with Accu-Ride 19.5" wheels.	1.00" hole/up to .5" depth	32131		6



20106



HEAVY DUTY WHEEL CENTERING TOOLS - EDUCATION COUNTER MAT

Create extra sales at the counter with this great teaching tool from SPC. This high quality, foam backed mat explains the problems caused by off-centered wheel and the benefits of using our Wheel Centering Sleeves. 11" x 17"

1-800-525-6505

Call for your nearest distributor, product info or Technical Assistance • In the USA and Canada

www.specprod.com



Heavy Duty WHEEL CENTERING PRODUCTS

STEER & DRIVE EXTERNAL SLEEVES



For steer and drive axles. This wheel centering sleeve slides over the studs and seats against the wheel face. This sleeve stays on the wheel and helps to reduce "wheel-off" condition. Sold in sets of 6 per axle. Zinc plated to resist corrosion.

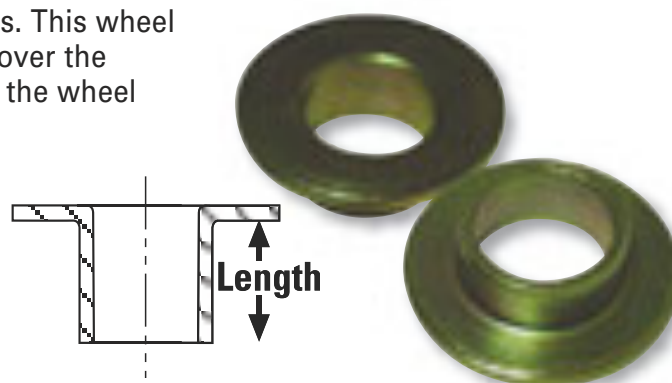

Wheel type	Stud Threads	Length Decimal	Length Fraction	Axle Position	Part No.
HEAVY DUTY					
Steel	22mm	.350"	23/64"	Steer	33140
Aluminum (see #33147 for smaller diameter sleeve)	22mm	.830"	53/64"	Steer	33141
Steel/Steel (see #33147 for smaller diameter sleeve)	22mm	.830"	53/64"	Drive	33141
Aluminum/Aluminum	22mm	1.560"	1-9/16"	Drive	33142
Aluminum/Steel	22mm	1.180"	1-3/16"	Drive	33143
"Heavy Duty" Aluminum - Michelin X One, 14" wide	22mm	1.100"	1-7/64"	Drive	33144
"Heavy Duty" Steel - Michelin X One, 14" wide	22mm	.600"	39/64"	Drive	33145
"Heavy Duty" Steel	22mm	1.440"	1-7/16"	Steer & Drive	33146
Aluminum (.010 smaller diameter than #33141)	22mm	.830"	53/64"	Steer	33147
Steel/Steel (.010 smaller diameter than #33141)	22mm	.830"	53/64"	Drive	33147
Alum. Wheel & Brake Drum (cent. wheel & drum)	22mm	1.310"	1-5/16"	Steer & Drive	33148
Aluminum Gunite Brake Drums #s 3753AX, 3754AX, Freightliner FL60, FL70 & M2, 3596BX & others	22mm	1.310"	1-5/16"	Steer	33149

Drum Type	Drum Numbers	Stud Threads	Dimensions	Part No.	Qty
Gunite	3721AX, 3800X, 3774X, & others	22mm	1.25" hole/.5" flange	33130	6
Centrifuse	90089BK, 9000X & others	22mm	1.25" hole/ .25"-5/16" flange	33131	6
Conmet	10009920	22mm	1.34"-1.37" hole/ .5" flange	33132	6
Conmet	107164, 107507, 107862, 107453, 10001781, 1001783, 10005331, 10005332	22mm	1.25" hole/.5" flange	33130	6
Gunite	3753AX, 3771X, 3600A, 3402X, 3807AX, 3598BX, 9006X	22mm	1.0" hole/.5" flange	33133	8
Webb	66864B, 61950B, 69547B, 89996B, 66807B, 66834F			33134	10



BRAKE DRUM SPACERS

For steer axles only. These spacers are used with either our Centering Pins or external sleeves to center brake drum holes to stud. Stays on the brake drum to help center. Zinc plated to resist corrosion. **Note:** On Gunite and Webb drums with 1.0" holes/.5" flanges you need to choose either 33133 for 8 spacers or 33134 for 10 spacers.



#33171 ELECTRIC DRILL WIRE BRUSH

Use to clean holes before mounting.



#33172 DEBURR KNIFE

Use to remove damaged edges.

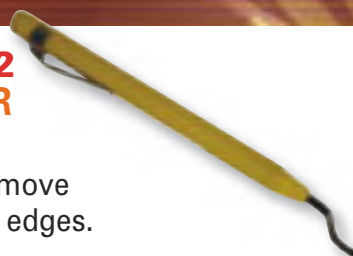

WHEEL CENTERING ACCESSORIES

These accessories will make installing our centering sleeves fast and easy.



www.specprod.com

Call for your nearest distributor, product info or Technical Assistance • In the USA and Canada

1-800-525-6505

Applications

Parts

Heavy Duty

Facing/Off Road

Tools

Accessories

Brake & CV

Gear/Index

Heavy Duty

TOOLS 33105



INNER BUDD NUT REMOVAL TOOL

- Ten wear-resistant teeth bite into broken or stripped inner budd nuts, and removes them easily.
- Investment cast and hardened for long life
- Limited Lifetime Warranty
- Designed to be used with a 1-1/2" socket or a 3/4" drive air gun, ratchet or flex handle, this great tool will pay for itself the first time you use it!

64225



ANGLE GAUGE

This angle gauge is an easy, accurate way for measuring frame and drive shaft angles. An ideal tool to ensure the drive line angle is still within specification for all types of vehicles.

64250

UNIVERSAL RADIAL RUN-OUT GAUGE

The Universal Radial Run-Out Gauge displays exact measurements for tire, wheel, and disc brake run-out. This gauge also measures ball joint and tie rod play and adjusts height to adapt to both automotive and heavy truck applications. This is a great tool when measuring those hard to reach areas.

Machined roller & heavy duty tripod for smooth, accurate readings



Easy to diagnosis front end vibration

- Measures out of round condition
- Pinpoints high and low spots in the tire
- Determines accurate centering of tire & wheel mounting
- Easy to use - only 2 adjustments

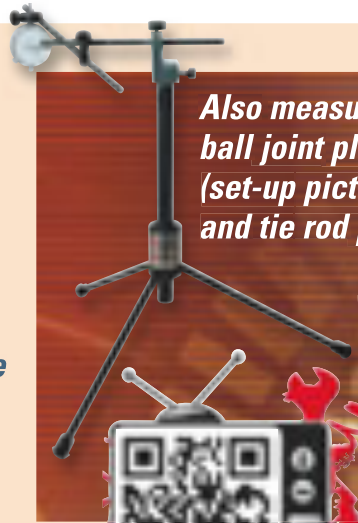

Also measures ball joint play (set-up pictured) and tie rod play

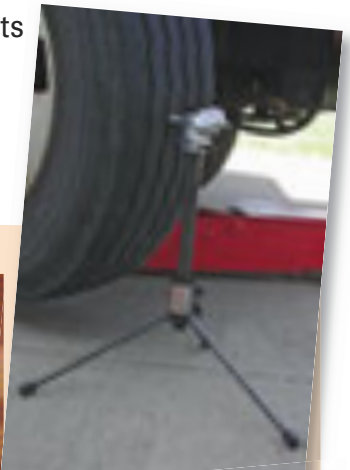

Includes ball joint/tie rod extenders

75580 75585



HEAVY DUTY TORQUE EXTENSIONS

These heavy duty 1" drive torque extensions provide a fast, simple method to achieve manufacturers' specified torque every time using an impact wrench. No more guesswork! Available in 400 lb-ft (#75580) and 550 lb-ft (#75585) applications, these extensions feature solid one piece construction and have a lifetime guarantee.

81309



STEEL WHEEL RIM STRAIGHTENING TOOL

For quick and easy removal of indentations on wheel flanges and rims of most vehicles. Allows proper tire seating, giving greater tire protection. Powder coated for added durability.

83125

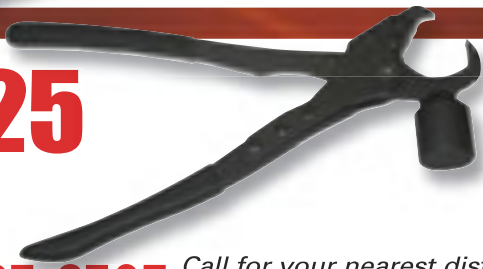

TRUCK WHEEL WEIGHT TOOL

Special grip hammer and pliers for removal and installation of truck wheel weights.

CHROME LUG NUT COVER TOOL

No-Mar coated jaws allow harmless removal and installation of chrome nut covers on light truck, motor home, and over-the-road truck lug nuts.



83788

NO MAR RIM GUARD

Protects from scratching chrome, aluminum, and painted truck wheels when removing lug nuts.

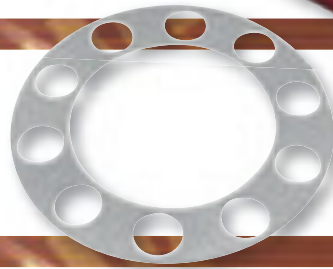

84238

FASTRAX™ CAMBER/CASTER GAUGE

This great tool is a must for your garage or shop. Accurate, portable alignment checks can be done quickly and easily with the FasTrax™ Adjustable Camber/Caster Gauge.

- Includes gauge and wheel mount (fits most wheels from 21" to 26").
- Includes extra length toe arms, heavy duty tape measure and no lip adapters.
- Displays Camber $\pm 4^\circ$ / Caster -4° to $+12^\circ$.
- Saves time and tires.
- Accurate, rugged and easy-to-use



91040



- *The most expensive costs of operating a fleet today is fuel and rubber*
- *By adding 5 minutes to your PMs you can protect your steer tires from premature wear and increase fuel mileage*
- *For less than the price of one steer tire you can **SAVE THOUSANDS OF DOLLARS PER YEAR!***

Perfect to add to your PMs - Check your alignment in just 5 minutes!!!!

HEAVY DUTY TURNTABLES (PAIR)

Full floating with enclosed ball bearings. Large, easy to read dial is quickly adjusted to zero. Pins are easy to remove and lock plates securely. May be used as portable floor units or on racks and pits. Sold in pairs.

Dimensions: 15" x 20" x 2"

Weight Limit: 10,000 lbs/wheel

PT-0750-14 - Replacement bearings

Unit Weight: 53 lbs each

Range: 100°



91800

TRUCK FRONT SLIP PLATE SET (PAIR)

This slip plate set is used in conjunction with the 99515 (see page 111) toe gauge. Made of steel, these slip plates allow the tire to move freely while the technician sets the toe. Sold in pairs.

Dimensions: 16" x 24" x 3/8" high.



91841

Heavy Duty

TOOLS 91844



TIRE MATING SQUARE

This tool checks for variance in dual tire mating. Right and left tires should not vary more than 1/2" in diameter. Compare tires by placing the long arm against the side wall and the short arm against the tread.

Dimensions: Long Arm - 48" Short Arm - 26"

91860



S-CAM BUSHING EXTRACTOR

Great tool for any Heavy Duty shop that works on low boys, reefers, log trucks and more. Now you can remove and replace the S-Cam bushing on air brake equipped trailers without removing the wheel hub or replacing the wheel seal. Save time and money yourself and for your customer with this innovative durable tool. Offer S-Cam replacement with every brake job.



91877



LO PROFILE EXTENDER BARS

The 91887 Lo Profile Extender Bar is designed to lower the measuring point of the tandems from the hub so that measuring the tracing of low profile trailers, such as car carriers and moving vans can easily be done. Can be used with either the 91888 or the 91890. Sold in pairs.

91887 KINGPIN EXTENSION - LO PROFILE



91887

This kingpin extension is for low profile trailer and car carriers. For simple and fast, accurate measurements from the kingpin center to the trailer tandems (to be used with 91888 or 91990 and 91891). Height 13-1/4" 3" Spring Motion

91889 TRAILER KINGPIN EXTENSION



91889

The trailer kingpin extension makes simple, fast, accurate measurements from the kingpin center to the trailer tandems. It is adjustable in length and has a spring-loaded cone that assures accurate holding to the kingpin (to be used with 91888 or 91990 and 91891).

Maximum Height 48" 6 Adjustments in 2" Increments 3" Spring Motion

91888

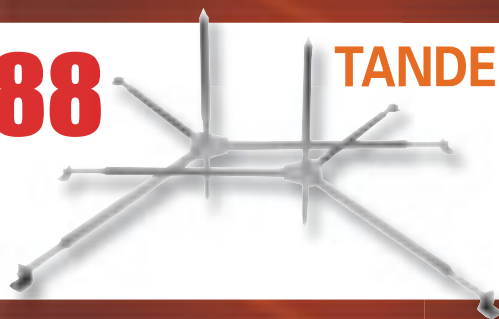

TANDEM AXLE CALIPER

These sets are used to aid in measuring the tracking of tandem axles in relationship to the kingpin suspensions and the front and rear axles on the tandem. Spring loaded and adjustable they establish a measuring point from the center of the wheel. To be used with 91889 and 91891. Sold in pairs. Fits steel wheels up to 22-1/2".

91890



TANDEM TRACKER SET FOR ALUMINUM WHEELS

This trailer tandem tracker set for **aluminum wheels, up to 28"**, is used to aid in measuring the tracking of the tandem axles in relationship to the kingpin extension and the front and rear axles on the tandem. They fit on the outside of the wheels so will not damage aluminum wheels and you don't need to remove the hub covers. Can also be used on steel wheels. Sold in pairs.

WORKING ON FLEET VEHICLES?

We have all the alignment parts and tools you need for your fleet of light duty vans and trucks. For alignment parts look up your application in our comprehensive application charts starting on page 7. For tools and accessories our tool section starts on page 122.

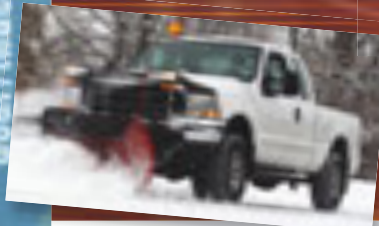

Applications
Parts
Heavy Duty
Tracing/Off Road
Tools
Accessories
Brake & CV
Gear/Index

TANDEM AXLE CALIPER

This light weight aluminum caliper is used to check the spacing between the axles of tractors or trailers for alignment and tracking. It has an easy to read scale in both metric and inches, with a range of 72". To be used with 91887, 91888 or 91890 and 91889.



91891

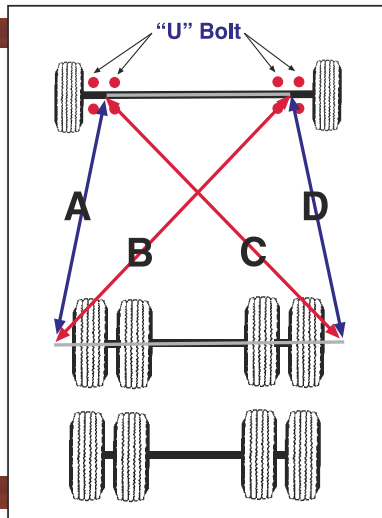

"U" BOLT EXTENSIONS (4)

This extension set is used to measure the tandem axles on tractors in relationship to the front spring "U" bolts. The extenders establish a measuring point on the front axles so you can make accurate measurements to the rear axle. Measurements "A" and "D" should be equal as well as measurements "B" and "C" if the vehicle is tracking correctly on the front axle. Includes four extenders - two with 3/4" threads and two with 7/8" threads. Use with 91877 or 91889 and 91888 or 91890.

91896



Tandem Alignment Systems



91988

STEEL WHEELS

This is a simple method for tracking the rear dual tandems on trucks and tractors. It includes the 91896 "U" Bolt Extensions, a pair of Lo Profile Extension Bars (91877) and a pair of 91888 Tandem Trailer Trackers. With this system the technician can easily check the A and D distances along with the B and C distances (diagram above) to see if the tandems are tracking correctly.



91990

ALUMINUM WHEELS

The 91990 is a simple method for tracking the rear dual tandems on trucks and tractors. It includes the 91896 "U" Bolt Extensions, a pair of Lo Profile Extension Bars (91877) and 91890 Tandem Tracker Set for Aluminum Wheels. With this system the technician can check the A and D distances along with the B and C distances (diagram above) to see if the tandems are tracking correctly.

HEAVY DUTY & O-T-R TOE BAR SET

99515 includes 10 in. extra-high stands, two standard 11 in. pointers, two long 17 in. pointers, an 8 ft. bar and 99516 scribe.

TOE BAR SET FOR LIGHT TRUCKS

99517 includes everything in the #99515 Toe Bar Set (two - 11" pointers, two - 17" pointers, 8 ft. bar, 99516 Scribe, 10" stands) plus an additional pair of 5" stands.



99515
99517

5" stands included in the 99517 Set

HEAVY DUTY SLIP PLATES (PAIR)

With a 2" height these heavy duty slip plates allow for a 2 inch total movement of the rear wheels while adjusting camber and toe alignments.

Wheel Platform: 13-7/8" x 11-1/2"

Base: 517" x 11-3/4" x 2

Weight Limit: 10,000 lbs/wheel



99801



Race Style Adjustable Upper Control Arms

These fully adjustable, rugged arms are recommended for circle track, road racing and drag applications. They allow the user to adjust the arm length and offset to attain the ultimate suspension geometry required to reach the winner's circle. Each arm can be adjusted up to 2" in length and all components are interchangeable and may also be ordered separately - see page 114-115. **SPC also offers arms for Muscle Cars, Street Rods, Corvettes and show applications - see our Application Guide (pages 7-45) for more!**

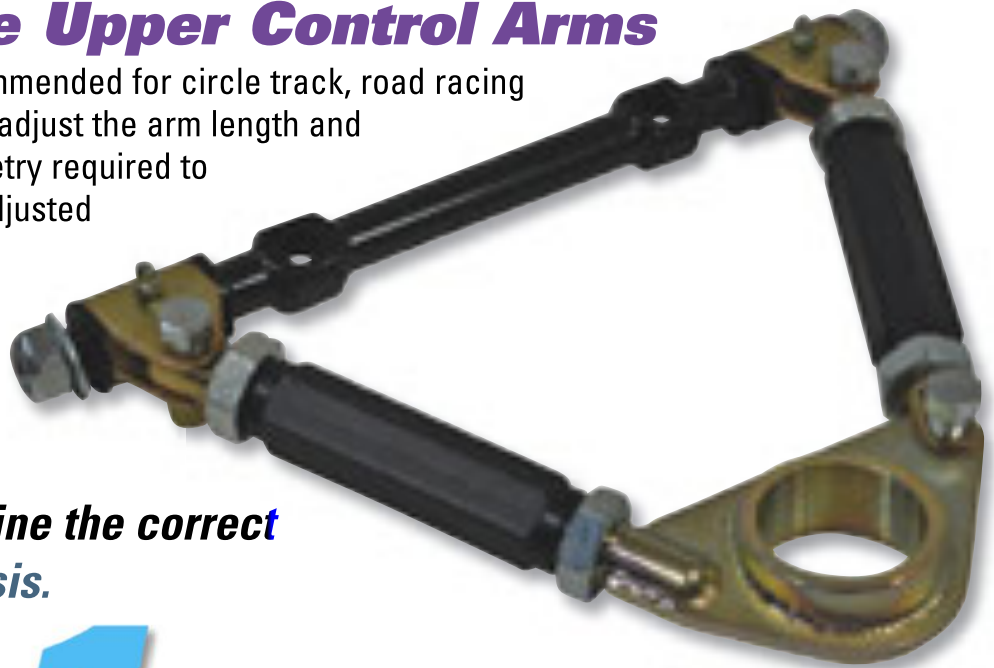

Follow the steps below to determine the correct control arm needed for your chassis.

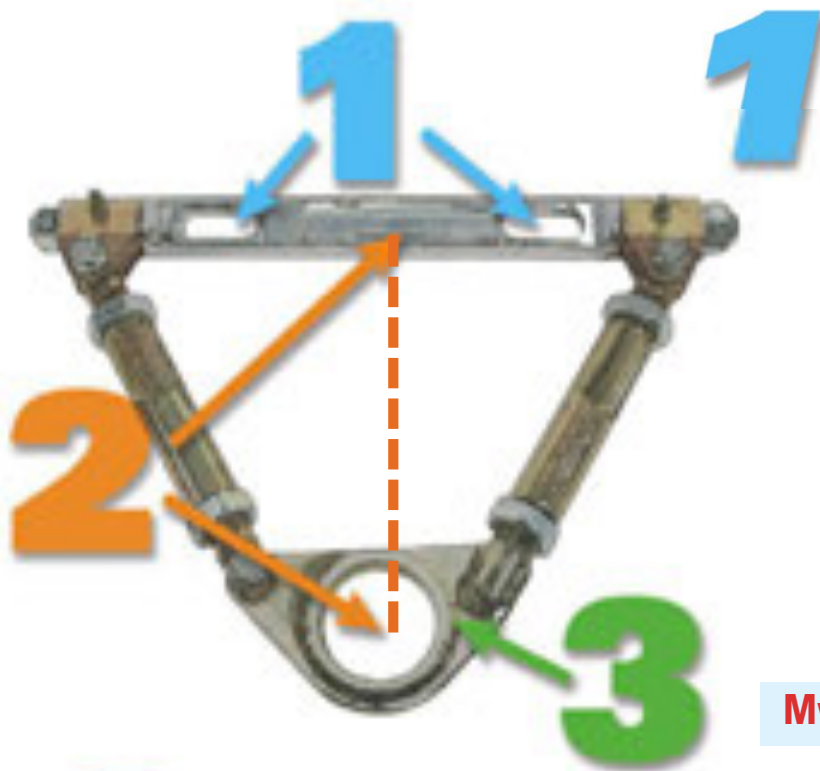

Step Number 1: Measure Cross Shaft Bolt Hole Spacing From Center-To-Center

SPC Performance offers these cross shafts including grease fittings with bolt hole spacings of:

- 5"
- 6" (slotted) *Aluminum* or 5-7/8" - 6" (slotted) *Steel*
- 6 1/2" (1st Gen 'F' Body 1967-69 Camaro; 1968-74 Nova-'A' Body Chevelle, El Camino, GTO, Olds 442)
- 6-15/16" Metric Stubs ('G' Body 1978-88 Chevelle, Grand National, Malibu Grand Prix; 1970-88 Monte Carlo; 1979-87 Cutlass Supreme)
- 7-3/4" 2nd Gen 'F' Body (1970-81 Camaro, Firebird)

My Cross Shaft Spacing Is: _____

Step Number 2: Measure Length of Control Arm

Measure from the middle of the cross shaft to the center of the ball joint.

- Steel Adjusting Sleeve lengths are available in 3-3/4", 5", 6", 8", and 9". Also available in black anodized aluminum in 4", 5" and 6" lengths.

My Control Arm Length Measures: _____

Step Number 3: Determine Type of Ball Joint Plate

- **Full Sized GM Truck Bolt In Ball Joint Plate** Measure center-to-center between the ball joint bolt holes that are farthest apart. This measurement should be 2-3/4" SPC Ball Joint part number is **92004**.
- **GM Metric (Midsized) Bolt In Ball Joint Plate** Measure center-to-center between the ball joint bolt holes that are farthest apart. This measurement should be 2-1/2" - SPC Ball Joint part #**92006**. Also in 20° - SPC Ball Joint part #**92008 & 92009**.
- **Chrysler Screw In Ball Joint Plate** - SPC Performance offers ball joint plates that are welded flat (0° - SPC part #**92003**) or at an angle (10° - SPC part #**92002**) for these screw in type ball joints.

My Type of Ball Joint is: _____

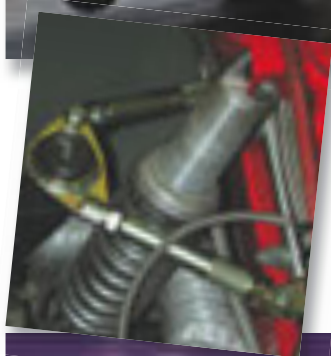

SPC Performance offers preassembled arms in the most popular configurations. These arms are fully adjustable and can give you all the camber and caster change you need to fine tune your alignment for any track. You will save time by being able to quickly and accurately dial in your alignment angles and at the same time you will improve your handling and tracking.

SPC Performance Arms Feature:

- Quality Steel or Aluminum (6" only) Cross Shaft with Pro Racing pivot assemblies or optional high strength rod ends with 3/4-16 thread and 5/8" bore
- Threaded steel adjusting sleeves
- Ball joint plates for Full Size, Screw-In or Metric Types

To order - find the **Cross Shaft** (or Rod End), **Adjusting Sleeve** and **Ball Joint Plate** that your chassis requires... it is that easy!

Don't see the combination that your vehicle requires? Check out our components - available individually - **and build your own!** (See more on our high quality components on pages 114 & 115.)

Part No.	Step 1 Your cross shaft	Step 2 Your Sleeve	Step 3 Ball Joint Plate
92142	5" Steel Cross Shaft	3-3/4" Adj Sleeve (Adjusts to 7"-9")	Chrys. 10° Screw-In Ball Joint
92244	6" Steel Cross Shaft	3-3/4" Adj Sleeve (Adjusts to 7"-9")	GM Full Size Ball Joint
92242	6" Steel Cross Shaft	3-3/4" Adj Sleeve (Adjusts to 7"-9")	Chrys. 10° Screw-In Ball Joint
92254	6" Steel Cross Shaft	5" Adj Sleeve (Adjusts to 8-1/4"-10")	GM Full Size Ball Joint
92252	6" Steel Cross Shaft	5" Adj Sleeve (Adjusts to 8-1/4"-10")	Chrys. 10° Screw-In Ball Joint
92546	6-15/16" Steel Cross Shaft	3-3/4" Adj Sleeve (Adjusts to 7"-9")	GM Midsize Metric Ball Joint
92542	6-15/16" Steel Cross Shaft	3-3/4" Adj Sleeve (Adjusts to 7"-9")	Chrys. 10° Screw-In Ball Joint
92556	6-15/16" Steel Cross Shaft	5" Adj Sleeve (Adjusts to 8-1/4"-10")	GM Midsize Metric Ball Joint
92552	6-15/16" Steel Cross Shaft	5" Adj Sleeve (Adjusts to 8-1/4"-10")	Chrys. 10° Screw-In Ball Joint
92646	7-3/4" Steel Cross Shaft	3-3/4" Adj Sleeve (Adjusts to 7"-9")	GM Midsize Metric Ball Joint
92656	7-3/4" Steel Cross Shaft	5" Adj Sleeve (Adjusts to 8-1/4"-10")	GM Midsize Metric Ball Joint
92344	6" Aluminum Cross Shaft	3-3/4" Adj Sleeve (Adjusts to 7"-9")	GM Full Size Ball Joint
92342	6" Aluminum Cross Shaft	3-3/4" Adj Sleeve (Adjusts to 7"-9")	Chrys. 10° Screw-In Ball Joint
92354	6" Aluminum Cross Shaft	5" Adj Sleeve (Adjusts to 8-1/4"-10")	GM Full Size Ball Joint
92352	6" Aluminum Cross Shaft	5" Adj Sleeve (Adjusts to 8-1/4"-10")	Chrys. 10° Screw-In Ball Joint
92044	Hi Strength 2 Pc. Rod End	3-3/4" Adj Sleeve (Adjusts to 7"-9")	GM Full Size Ball Joint
92042	Hi Strength 2 Pc. Rod End	3-3/4" Adj Sleeve (Adjusts to 7"-9")	Chrys. 10° Screw-In Ball Joint
92043	Hi Strength 2 Pc. Rod End	3-3/4" Adj Sleeve (Adjusts to 7"-9")	Chrys. 0° Screw-In Ball Joint
92046	Hi Strength 2 Pc. Rod End	3-3/4" Adj Sleeve (Adjusts to 7"-9")	GM Midsize Metric Ball Joint
92054	Hi Strength 2 Pc. Rod End	5" Adj Sleeve (Adjusts to 8-1/4"-10")	GM Full Size Ball Joint
92052	Hi Strength 2 Pc. Rod End	5" Adj Sleeve (Adjusts to 8-1/4"-10")	Chrys. 10° Screw-In Ball Joint
92053	Hi Strength 2 Pc. Rod End	5" Adj Sleeve (Adjusts to 8-1/4"-10")	Chrys. 0° Screw-In Ball Joint
92056	Hi Strength 2 Pc. Rod End	5" Adj Sleeve (Adjusts to 8-1/4"-10")	Chrys. 0° Screw-In Ball Joint

We also have pre-built Racing Arms for Corvettes - See Page 93!

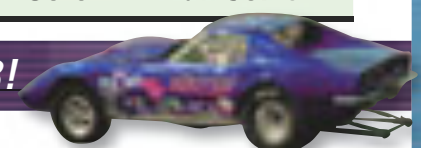

Racing

Build your own Arm

With our high quality components

If we don't have a preassembled arm with the specs you need you can purchase the individual components and get exactly the configuration you want for racing, rod, street or drag.

Our new chromoly cross shafts are lighter and stronger - perfect for racing or street.



Cross Shafts

Steel or Aluminum Cross Shafts in a variety of sizes and configurations including grease fittings or bushings. Measurement is from center to center on holes.

Complete Cross Shaft Assemblies

94100 | 5" Steel Stock/Mustang II | Includes 2 Straight Pivots

Customizable Cross Shafts

Part#	Shaft Hole Spacing	Shaft Material	Racing Pivots (Order 2) <i>Delrin Bushing</i>	Street Pivots (Order 2) <i>Clevite Bushing</i>
			Offset Style	Offset Style
93400	5"	Steel	92025	94014
93410	5-1/2"	Steel	92025	94014
93420	5-7/8" to 6"	Steel	92025	94014
93440	6" <i>Slotted Mount</i>	Aluminum	92025*	N/A
93450	6-1/2"	Steel	92025	94014
93430	6-5/16"	Steel	92025	94014
93460	6-11/16"	Steel	92025	94014
93470	6-15/16"	Steel	92025	94014
93480	7-3/4"	Steel	92025	94014

* Note: On 93440 Aluminum Shafts the 92025 pivot bushings will need to be removed before installing.

Adjusting Sleeves

These sleeves are the perfect fit with our pivot studs and ball joint plates.

Sold individually.

Part #	Length	Sleeve Material	Part #	Length	Sleeve Material
92040	3-3/4"	Steel	92060	6"	Steel
92045	4"	Aluminum	92065	6"	Aluminum
92050	5"	Steel	92080	8"	Steel
92055	5"	Aluminum	92090	9"	Steel

Upper Control Arm Components

A variety of assemblies along with nuts and bolts for your arm. **Sold individually.**

Part #	Description	Part #	Description
92005	UCA End Pivot Stud (Cross Shaft End)	92025	Offset Race Pivot Assembly w/Delrin Inserts
92010	Right Hand Jam Nut - 3/4" - 16	94013	OE Style Bushing Only
92011	Left Hand Jam Nut - 3/4" - 16	94014	Offset Street Pivot Assembly w/OE Style Bushings
92012	Retaining Ring Clip	94041	Street Kit (threaded studs, lock nuts, bolts, jam nuts, OE style offset pivots - 2 ea.)
92013	Pivot Plate Stud w/Nut	97100	Hi Strength 2 Piece Rod End - 3/4" - 16 LH
92014	End Pivot Bolt		
92019	Lock Nut for 92014		
92021	Race Kit (threaded studs, lock nuts, bolts, jam nuts, offset pivots w/Delrin Insert - 2 ea.)		

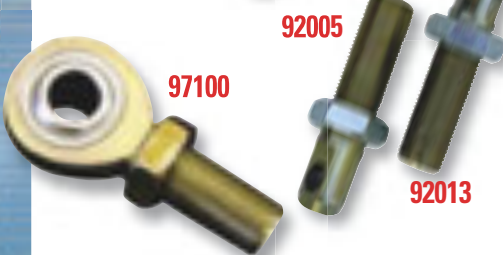
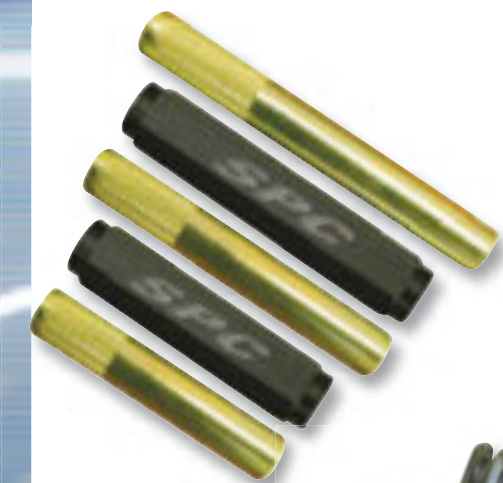

Applications

Parts

Heavy Duty

Racing/Off Road

Tools

Accessories

Brake & CV

Gear/Index



Racing

Ball Joint Plates

SPC Ball Joint plates in a variety of styles to complete your adjustable control arm along with OE style ball joints (sold separately-below).

NEW W-I-D-E 10 & 20 degree screw in ball joint plates accommodate larger coil springs being used on many late model racing chassis. The wide plate allows plenty of room for both caster and offset adjustment.

Part #	Type	Use with these Ball Joints (not included)
92002	Chrysler Screw In Plate - 10°	94002
92003	Chrysler Screw In Flat Plate - 0°	94002
92004	Full Size GM Bolt In Plate	94004 standard
92006	Midsize GM Metric Bolt In Plate - 0°	94006 standard, 94017 extended
92007	GM Tri 5 Bolt In Plate	94003
92008	Left Midsize GM Metric Bolt In Plate - 20°	94006 standard, 94017 extended
92009	Right Midsize GM Metric Bolt In Plate - 20°	94006 standard, 94017 extended
92033	NEW Wide Mouth Screw-In Plate - 10° (Right)	94002 (for larger coil springs)
92035	NEW Wide Mouth Screw-In Plate - 20° (Drivers)	94002 (for larger coil springs)



Ball Joints

.5" Extended Length OEM Style Ball Joints

These greaseable, OEM style extended length ball joints are ideal to improve camber gain and increase control arm to frame clearance.



Ideal for the ultimate in handling performance.

Part #	Moog Equiv	Description
94016	K5103.5	Lower Ball Joint for GM 'A' Bodies
94018	K6145.5	Lower Ball Joint for GM 'G' Bodies (Press in for 95336 Lower Arm)
94017	K5208.5	Upper Ball Joint for GM Mid Size Bolt In Metric Plate
94019	K5108.5	Upper Ball Joint for GM 1st Gen 'F' Body & 'A' Body ('64 -'72)



Stock Length OEM Style Ball Joints

These ball joints fit a variety of GM and Chrysler applications. If you are installing our Adjustable Control Arms these ball joints are the perfect fit to your suspension upgrade.

Part #	Moog Equiv	Description
94002	K772	Upper Chrysler Screw-In Ball Joint  68880 - Socket pg 122
94003	K6034	Upper GM C2/C3 Corvette & Tri 5 Bolt-In Ball Joint
94004	K6024	Upper GM Full-Sized Bolt-In Ball Joint
94006	K5208	Upper GM Mid-Sized Metric Bolt-In Ball Joint
94007	K6346	Upper C4 Corvette Bolt-In Ball Joint
94008	K719	Lower Chrysler Screw-In Ball Joint  68880 - Socket pg 122

Jack and Vic Parker with High Tech Racing (#55 left & above) and Leary Racing

with driver Roger Avants (#27 right) know dialing in your alignment angles is a critical element when it comes to putting together a winning season. Our adjustable arms are easy to adjust and optimize your handling for changing track conditions.

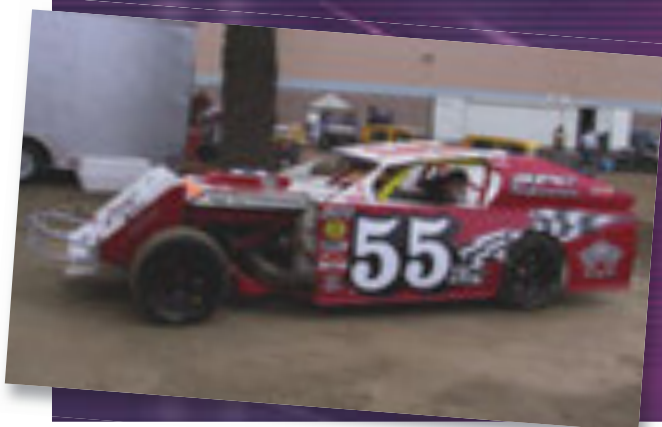

Racing xAxis™ - Sealed Flex Joint



Designed to replace many OE style bushings, SPC's **xAxis™ Sealed Flex Joint** retains chassis design parameters. **xAxis™** is recommended for use as a replacement when higher performance of joint angularity is desired - perfect for race and off-road builders.

Features

- Sealed joint retains grease and excludes contaminants
- Highly polished electroless-nickel finish on ball maximizes durability
- Up to 45° angularity for high mis-alignment requirements
- Common sizes that builders and racers need

Benefits

- Reduced compliance and deflection vs rubber and poly joints
- Improved durability vs spherical bearings and poly bushings
- Increased angularity vs rubber and poly bushings
- Engineered to be a direct fit for many popular street/race or HD off-road applications

Electroless-nickel plated ball provides hard, smooth wear surface for long life



Corrosion and wear resistant nylon inner sleeve reduces compliance



Zinc plated retaining rings keep boot secure throughout increased joint travel



Easily replaceable rubber boots protect joint from elements

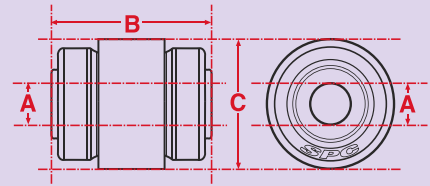

	Part No.	Bolt Size (A)		Width (B)		Outer Dia (C)		Application Notes
		mm	Inch	mm	Inch	mm	Inch	
Builder Series	15605		0.375		1.500		1.500	Builder Size
	15607		0.500		2.000		1.750	Builder Size
	15609		0.625		2.500		2.000	Builder Size
	15611		0.750		3.250		2.500	Builder Size
Jeep Series	15613	10			2.000		1.8125	TJ Upper Control Arm (Front/Rear)
	15615	12			2.000		1.8125	JK Upper Control Arm (Front)
	15617	14			1.625	38.5		JK Track Bar (OEM)
	15619	14			2.625		2.250	TJ / JK Lower Control Arm (Fits any arm that accepts OE bushing)
OE Upgrade Series	15625	10		40			1.750	81350/81360 Upgrade for OE Audi UCAs Builder Size - Go to www.specprod.com/BuilderSeries for more
	15627	12		42		40		Upgrade part for 67660
	15629	12		45		40		Builder Size - Go to www.specprod.com/BuilderSeries for more
	15631	12		47		40		Builder Size - Go to www.specprod.com/BuilderSeries for more
	15635	12		50		40		Builder Size - Go to www.specprod.com/BuilderSeries for more Direct O.E. for Dodge Caliper, Jeep Compass/Patriot, Mitsubishi Lancer AWD
	15637	12		57		40		Builder Size - Go to www.specprod.com/BuilderSeries for more
	15639	14		40		40		Builder Size - Go to www.specprod.com/BuilderSeries for more

MULTI-LIGNMENT™ WASHERS



These patented washers are the answer for everyone who has ever tried to re-install that slightly bent skid plate where the holes just don't want to line up!

Easily seated, these washers require a minimum .250 inch plate material thickness and accommodate ±.200" bolt misalignment in any direction from center. Used with flat head socket fasteners, they provide a clean, flush profile.

US Patent#
US2006/0088398A1

A 2" x 90° countersink tool is required to prepare your skid plate

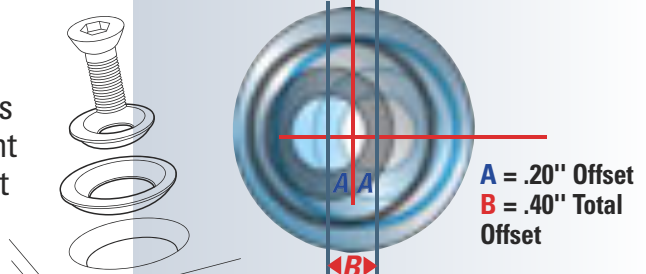

Part No.	Out. Dia.	Bolt Size	Qty.
15510	2.0"	12mm	1 pr
15515	2.0"	12mm	6 pr

A = .20" Offset
B = .40" Total Offset



Racing Tubular Chassis Components

ROD END RECEIVERS

Material Spec: 4140 N Chromoly Steel Includes Grade 8 bolt, metal locknut and 2 AN washers

Welds into stock tubing sizes.
Cinch bolt maintains high clamping force.



ROUND ROD END RECEIVERS

RH Thread Part #	15120	15110	15100	15090	15080	15092	15082
LH Thread Part #	15125	15115	15105	15095	15085	15097	15087
Thread Size (A)	1/2" - 20	5/8" - 18	3/4" - 16	7/8" - 14	1 1/4" - 12	7/8" - 14	1 1/4" - 12
Outside Dia. (B)	.745"	.870"	1.120"	1.370"	1.870"	1.260"	1.760"
Thread Length (C)	1.2"	1.3"	1.4"	1.5"	1.7"	1.5"	1.7"
Overall Length (D)	1.813"	1.938"	2.125"	2.250"	2.563"	2.250"	2.563"
Nominal Tube Size	.875" OD	1.000" OD	1.250" OD	1.500" OD	2.000" OD	1.500" OD	2.000" OD
Recommended Tube Wall Thickness	0.065"*	0.065"*	0.065"*	0.065"*	0.065"*	0.120"**	0.120"**

* .065 receivers may be turned down to fit other tubing sizes ** We recommend that .120 receivers not be turned down

SQUARE ROD END RECEIVERS

RH Thread Part #	15170	15160	15150	15140	15130
LH Thread Part #	N/A	N/A	N/A	N/A	N/A
Thread Size (A)	1/2" - 20	5/8" - 18	3/4" - 16	7/8" - 14	1 1/4" - 12
Width (B)	0.688"	0.875"	1.063"	1.250"	1.813"
Thread Length (C)	1.2"	1.3"	1.4"	1.5"	1.7"
Overall Length (D)	1.813"	1.938"	2.125"	2.250"	2.563"

3 PIECE SPHERICAL ROD ENDS

RH Thread Part #	15474	15476	15478	15480	15482
LH Thread Part #	15475	15477	15479	15481	15483
Bore	.50 Bore	.625 Bore	.750 Bore	.875 Bore	1.00 Bore
Thread Size	1/2"-20	5/8"-18	3/4"-16	7/8"-14	1 1/4"-12

SPHERICAL BEARING RECEIVERS

Material Spec: 4140 N Chromoly Steel Includes Retaining Ring

Part #	15065	15060	15055	15050	15045	15040	15042
Bearing Dia. (A)	0.8125"	1.0000"	1.1875"	1.3750"	1.6250"	2.1250"	2.7500"
Bear. Race Width (B)	0.4060"	0.5050"	0.5670"	0.6300"	0.7550"	1.0050"	1.099"
Receiver OD (C)	1.063"	1.250"	1.483"	1.625"	1.925"	2.500"	3.250"
Receiver Height (D)	0.58"	0.71"	0.84"	0.92"	1.06"	1.41"	1.527"
Bearing Offset (E)	0.0170"	0.0125"	0.0265"	0.0150"	0.0025"	0.0025"	0.012"

SPHERICAL BEARINGS

With Teflon Liners

Part #	15465	15460	15455	15450	15445	15440	15442
Corresponds to Receiver Number	15065	15060	15055	15050	15045	15040	15042
Inside Diameter	0.375"	.500"	.625"	.750"	.875"	1.000"	1.500"
Outside Diameter	0.8125"	1.0000"	1.1875"	1.3750"	1.6250"	2.1250"	2.7500"

E - Centerline of receiver to centerline of bearing race

HIGH MIS-ALIGNMENT INSERTS (Pair)

Material Spec: Hardened Stainless Steel

Part #	15032	15028	15015	15020	15018	15010	15012	15024	15022
Shoulder OD (A)	0.500"	0.625"	0.750"	0.875"	0.875"	1.000"	1.000"	1.500"	1.500"
Internal Dia. (B)	0.375"	0.500"	0.500"	0.500"	0.625"	0.625"	0.750"	0.625"	0.750"
Shoulder Length (C)	0.300"	0.345"	0.433"	0.433"	0.385"	0.675"	0.675"	0.608"	0.683"
Part Length (D)	0.730"	0.720"	0.875"	0.875"	0.950"	1.080"	1.080"	1.790"	1.790"
Stack Length (E)	1.500"	1.500"	1.750"	1.750"	2.000"	2.160"	2.185"	3.600"	3.6250"
Mis-Alignment Angle	21 Deg.	24 Deg.	30 Deg.	30 Deg.	30 Deg.	30 Deg.	28 Deg.	29 Deg.	30 Deg.

OFF ROAD & OFF ROAD RACING

JounceShocks™

US Patent 7140601 B2

The JounceShock is a patented form of bump shock that will maximize the capacity and performance of your suspension. The nitrogen charged secondary shock adds additional compression damping and controlled rebound to your vehicle's system. The result is: exponential suspension bottoming protection, increased stability and handling at all speeds, and reduced stress and loads for both the vehicle and driver.

Benefits

- Eliminate suspension bottoming
- Increase stability and improve handling at all speeds
- Enhance rock crawling ability
- Improve towing stability and load capacity

Double your suspension capacity

- Off-Road Racing
- Recreational Off-Road
- Lifted Trucks
- Fleet Vehicles
- Rock Racing
- Stock Trucks
- Rock Crawling



25710 1.5" TRAVEL JOUNCESHOCK

6" extended unit is great for tight spaces with 1:1, up to 3:1 motion ratios

25715 3.0" TRAVEL JOUNCESHOCK

9" long base unit is ideal for 1:1 motion ratios

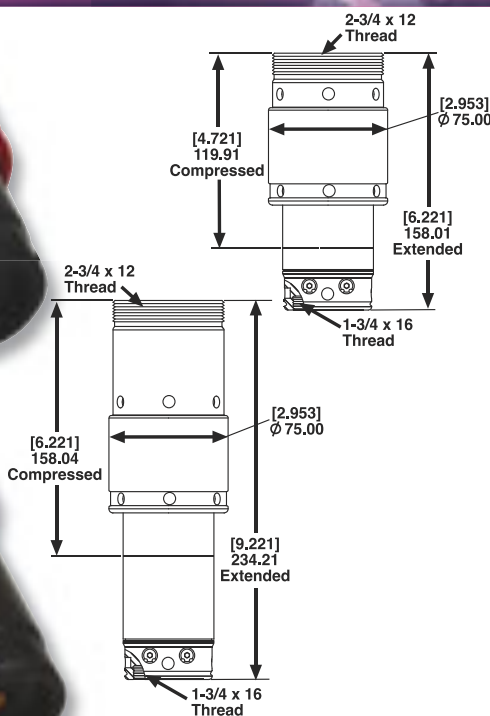

25710

UNIVERSAL 1.5" TRAVEL UNIT

- 2-3/8" Bore
- Adjustable nitrogen pressure and oil fill
- Adjustable Compression & Rebound
- 6.22" Extended
- 4.72" Compressed

25715

UNIVERSAL 3.0" TRAVEL UNIT

- 2-3/8" Bore
- Adjustable nitrogen pressure and oil fill
- Adjustable Compression & Rebound
- 9.22" Extended
- 6.22" Compressed

JOUNCESHOCK REBUILD KITS

The seals, O-Rings, wear bands, and valve pieces needed to rebuild your JounceShocks. **25712 Kit** includes everything you need to rebuild 1 shock and **23713 Kit** includes rebuild parts for four shocks. Both include the Shock Valve Extension (#25515) for recharging your JounceShock.



25712 Single (1) rebuild kit

25713 Four (4) rebuild kits

25515 VALVE EXTENSION

Required to adjust nitrogen pressure in JounceShocks. Included with our Rebuild Kits (left - #25712 and #25713).



25520 PIN WRENCH SET

This versatile pin wrench set of two double-ended tools is specially engineered to cover 7 different diameters: 2", 2-3/16", 2-1/4", 2-3/4", 2-7/8", 3", and 3-1/4". These sizes are perfect for working with JounceShock and JounceShock End Mounts. This economical pin wrench set would be an excellent addition to any builder's tool box.



15° FLEX MOUNT **25501**

This mount can be welded or bolted to your mounting point, giving you 7.5° of articulation in any direction and will most often be used with the Cupped Foot and Domed Target kits (part nos. 25601, 25613).

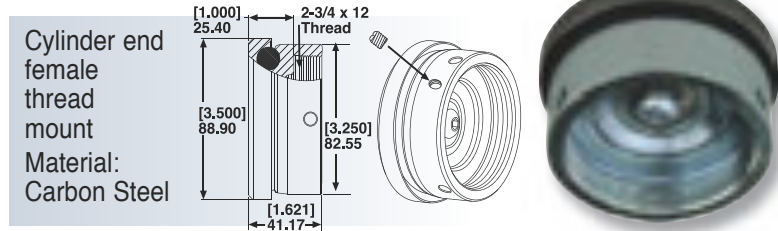

FIXED MOUNT **25505**

The Fixed Mount can be welded to your existing structure. It provides a simple attachment point for your JounceShock and will most often be used with the Domed Foot on the shaft end of the shock (part nos. 25602, 25604, 25605).

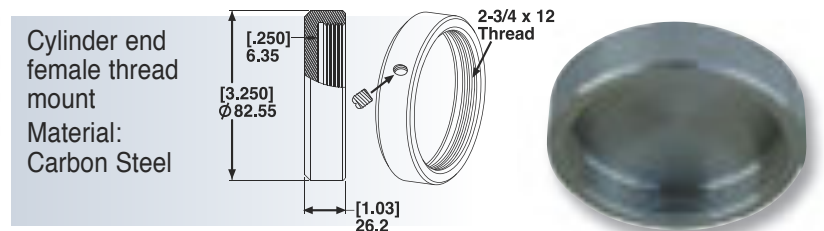

CONCENTRIC CARRIER/ BOLT ON MOUNT **25508**

The Concentric Carrier/Bolt on Mount can be sandwiched above your spring upper seat or bolted to the bottom of a frame. Plate can be trimmed as needed to bolt or weld to your frame.

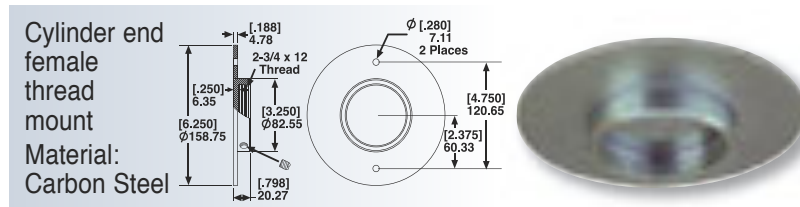

FRAME SIDE MOUNT **25530**

This universal Mount provides a versatile bolt/ welded on option to mount your JounceShock in a fixed position, such as the side of your frame rail (trim-to-fit).

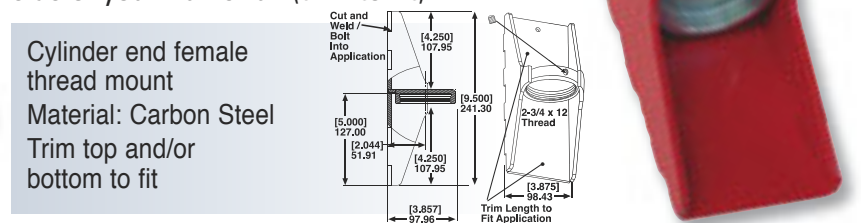

CUPPED FOOT & DOMED TARGET

The Cupped Foot and bolt/welded on Domed Target are typically used with the Flex Mount to assure ideal JounceShock alignment through your vehicle's suspension travel.

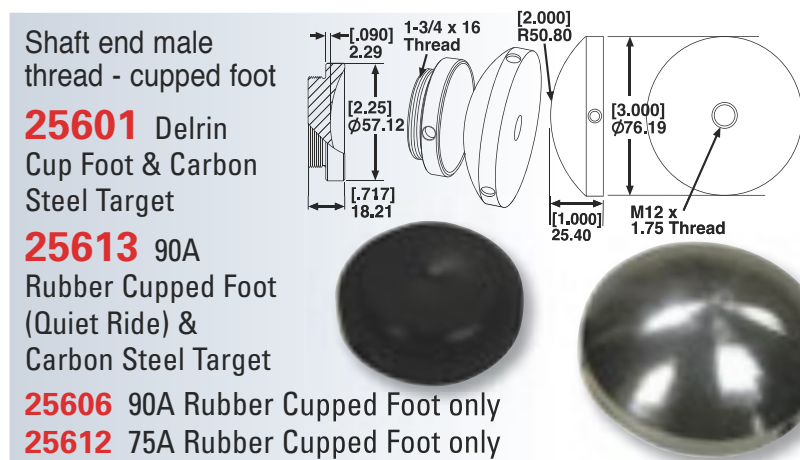

Lower Ends DOMED FOOT

The Domed Foot screws directly into the shaft of the JounceShock. This is the traditional bump shock end and is most often used in applications with some 'scrub' (lateral motion) on a Target Plate. It can also be used in conjunction with the Shaft Extension Kit (part no. 25603). Your choice of materials.

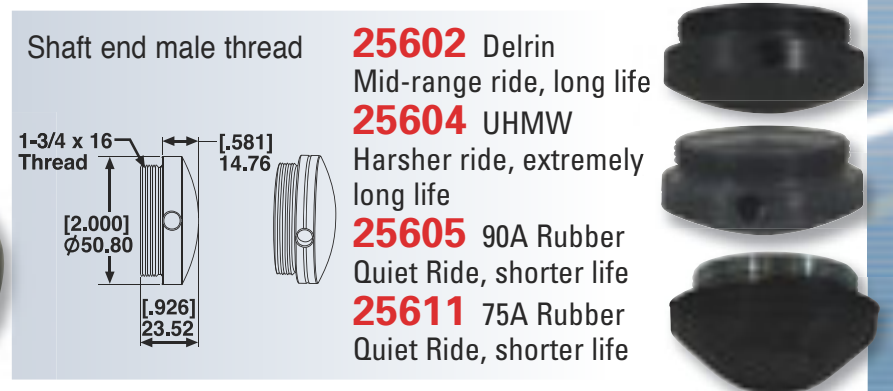

SHAFT EXTENSION KIT

For lifted applications, this a cut to length adapter will add 1" to 7" inches to the shaft of your JounceShock allowing you to fine tune contact points as well as a smaller dimension to stab at a target (sold singly).

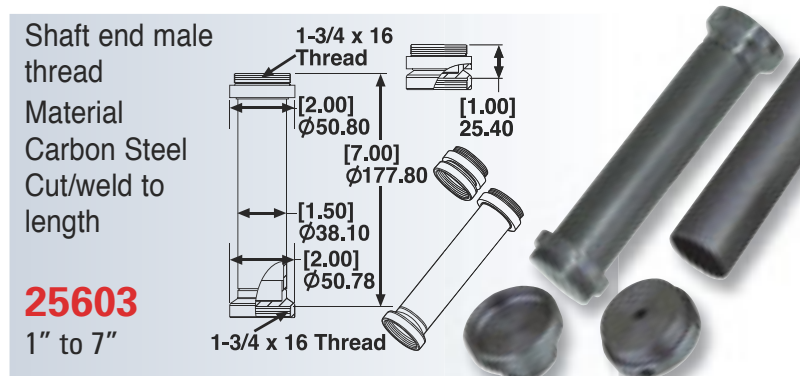

JOUNCESHOCK BODY BOOT

This Urethane Guide will protect your JounceShock from contact with suspension parts. Perfect when using JounceShocks mounted within a coil spring.

25615 Material: Urethane

JOUNCESHOCK SHAFT BOOT

These boots will keep 'stone blast' caused by rocks and dirt from damaging your JounceShocks and causing seal failure.

25701 Protective Boot - 1.5" Travel JounceShock (#25710)
25702 Protective Boot - 3.0" Travel JounceShock (#25715)

Racing Complete JounceShock™ Systems

We'll fit you!

We have pre-made systems for some of the most popular off road vehicles in the market. With these complete systems it is easy to get the benefits of a JounceShock system into your truck. Systems include everything you need from custom mounts to the nuts and bolts and detailed instructions.



	FROM	TO	DRIVE	FRONT	REAR	TOTAL
CADILLAC/CHEVY/GMC						
Colorado/Canyon	2004	2011	4x4, 4x2	25872		
Silverado 1500	2007	2012	4x4, 4x2	25852	25854	25850
Sierra 1500	2007	2010	4x4, 4x2	25852	25854	25850
Silverado/Sierra 1500	1999	2006	4x4	25862	25864	25860
Silverado/Sierra 1500	1999	2006	4x2		25864	
Escalade/Suburban/Yukon 1500	2007	2012	4x4, 4x2	25852		
Tahoe 1500, Avalanche 1500	2007	2012	4x4, 4x2	25852		
Avalanche/Yukon 1500	2000	2006	4x4, 4x2	25862		
Escalade 1500	2001	2006	4x4, 4x2	25862		
FORD						
F150/Raptor	2004	2012	4x4, 4x2		25824	
F250, F350 Super Duty	2005	2010	4x4	25832	25834	25830
HUMMER						
H3	2006	2010	4x4, 4x2	25872	25874	25870
JEEP						
Wrangler (JK)	2007	2013	4x4, 4x2	25732	25734	25730
NISSAN						
Frontier	2005	2012	4x4, 4x2	25792	25794	25790
Navara D40	2005	2012	4x4, 4x2	25792	25794	25790
Pathfinder	2005	2012	4x4, 4x2	25792		
Xterra	2005	2012	4x4, 4x2	25792		
TOYOTA/LEXUS						
4Runner	2003	2009	4x4, 4x2	25762	25784	25780
4Runner	1996	2002	4x4, 4x2	25742	25746	25750
FJ Cruiser	2007	2009	4X4	25762	25784	25780
GX470	2003	2009	4X4	25762	25784	25781
Hilux MK6	2005	2012	4x4, 4x2	25762	25764	25760
Prado 120 Series Land Cruiser	2002	2009	4x4, 4x2	25762	25784	25780
Prado 90 Series Land Cruiser	1996	2002	4x4, 4x2	25742	25746	
Tacoma 4x4/Pre Runner	2005	2012	4x4, 4x2	25762	25764	25760
Tacoma	1996	2004	4x4	25742	25744	25740



Applications Parts Heavy Duty Racing/Off Road Tools Accessories Brake & CV Gear/Index

1-800-525-6505

Call for your nearest distributor, product info or Technical Assistance • In the USA and Canada

www.specprod.com



RACING TOOLS & EQUIPMENT

FLARED HOLE DIES

15810 15815

Part #	Dia.	Part #	Dia
15835	.75"	15870	3.0"
15840	1.0"	15875	3.5"
15850	1.5"	15880	4.0"
15860	2.0"	15885	5.0"
15865	2.5"	15890	6.0"

Set #	Dies Included
15810	15835, 15840, 15850, 15860, 15865
15815	15870, 15875, 15880

Often called "dimple dies," Flared Hole Dies are used in sheet-metal fabrications to provide rigidity and strength to flat panels. Due to the resulting high strength-to-weight ratio flared holes are found in many aircraft and race vehicle designs.

Beginning with comprehensive finite element analysis supported by extensive prototype testing, our light weight Flared Hole Dies are engineered to provide the optimum combination of performance attributes:

- Eliminate edge tearing when used on chromoly, even with edges hardened by laser cutting methods
- Will flare holes in chromoly up to .090" thick or flare holes in up to .125" mild steel
- Manufactured from high quality hardened tool steel
- Available for hole diameters from 3/4" to 6"

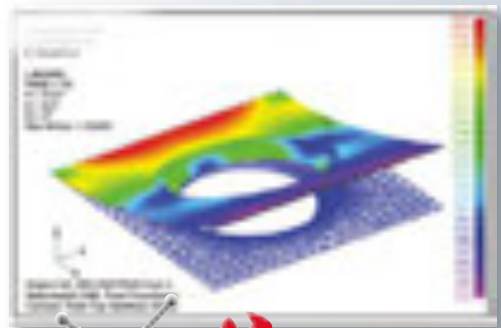

FASTRAX™ CAMBER / CASTER GAUGE

Portable, hands-free alignment can be done quickly and easily with the **FasTrax™ Adjustable Camber/Caster Gauge**. This tool will help you fine tune your alignment for optimal tracking and handling while minimizing alignment headaches.

- Includes gauge and wheel mount.
- Saves time and tires.
- Displays Camber ±4° / Caster -4° to +12°.
- Accurate, rugged and easy-to-use.

91000 Standard - Fits wheels 13" to 17"
Optional Toe Adapter Kit (91100) sold below.

91000

91010 Performance - Fits wheels 17" to 22"
Optional Toe Adapter Kit (91100) sold below.

91025 Off-Road - Fits Wheels 13" to 17"

Align off-road wheels - tire sizes up to 44".

Includes longer toe arms, bungie cord & tape measure.

91025

91030 No Lip Adapter

A quick adapter to attach the FasTrax to wheels without outer "lip". Fits on the 91000, 91010 and 91025.

91030

91100 Optional Toe Adapter Kit

Simply lower the toe arms and insert tape measure into slot. Then measure to opposite tire reference point for accurate and fast toe readings. Includes 2 arms and reinforcement blocks that install easily onto either the 91000 or the 91010.



91100



91000
w/91100



91025

See page 138 for more on our Popular FasTrax™

TOOLS

87910



ALIGNMENT TOOL BOARD

This board set gives technicians the tools needed to complete today's modern alignments quickly and efficiently. Contains our most popular tools, with a handy plastic peg storage board to keep all your alignment tools in one easy to reference location.

BOARD INCLUDES ONE EACH OF THE FOLLOWING:

Tool Number	Page	Description
8370	123	Tie Rod Puller
37985	124	4-Way Ball Joint/Tie Rod Separator
45938	127	Colorado/Canyon 4WD Alignment Socket
45940	127	GM Express Van Tool
71959, 71969, 71979, 71989, 71999	128	Tie Rod Tools
74910	129	Cam Knock Out Punch
77350	131	Heavy Duty Tie Rod Tools
77880	131	Ford OE Sleeve Puller
81139	132	Magnetic Adj. Camber Gauge
83775	132	Cas/Cam Tool - 93 & Up F-Body
85127	133	3/8" Carbide Rotary File
85137	133	3/8" Rotary File for Aluminum
87560	134	Honda 24mm Toe Tool
99918	137	Wheel Spreader Bar - A must for Mercedes

27



PITMAN ARM SEPARATOR

For use on most cars and some light trucks. The tapered wedge easily removes the pitman arm from the shaft with just a few sharp hammer blows.

DIMENSIONS: 1" opening, 12" overall length.

Slide Hammers/Pullers

498



FRONT HUB & AXLE PULLER

498 removes front hubs on vehicles with independent front suspensions. Remove screw and use it with 499 axle puller to remove axles in compact cars.

498

APPLICATIONS

Compact cars

SET INCLUDES

- 498-1 Yoke
- 498-2 Center screw
- 498-3 Jam nut

499



FLANGE TYPE AXLE PULLER

Flange Type Axle Puller can be used as a regular wheel puller or hub puller, as well as a flange type puller. The bolt circle range is from 4-1/2" to 5-1/2", which covers all cars and small trucks with flange type axles. The four slots allow this tool to be used on 4, 5, or 6 stud designs.

499

APPLICATIONS

All cars and small trucks with flange type axles

SET INCLUDES

- 499-1 Yoke
- 499-2 Center rod assembly
- 499-3 Jam nut
- 499-4 Hammer

Check out our CV Joint Fork #38620 for use with the 499 (page 124)

CAUTION: Not for use with impact wrenches (air tools).

SPANNER WRENCH

Thin walled spanner wrench designed specifically for installation and removal of O.E. and 23000 (page 50) screw in 4WD alignment sleeves.



4169

APPLICATIONS

Dodge RWD:

1987 - 04 Dakota
1998 - 03 Durango

DODGE CAMBER TOOL

This wrench is specifically designed to access the hard to reach upper control arm bolts used to adjust caster/ camber on RWD Dodge Durangos and Dakotas.



6140

APPLICATIONS

Most compact/standard passenger cars and light trucks

TIE ROD TOOL

Four position feature and 360° rotation lets you grip the sleeve properly, even with limited access. Fits most passenger cars and light trucks.



7023

CHRYSLER/FORD CAMBER/CASTER TOOL

An excellent tool for fast camber-caster changes on most older Chrysler and Ford products w/SLA style suspensions.



8286

APPLICATIONS

Chevrolet: 1982 - 92 Camaro
Pontiac: 1982 - 92 Firebird
1982 - 92 Trans Am
w/adjustable upper strut towers

CAMARO-FIREBIRD FRONT CAMBER TOOL

The 8292 tool makes for easy, fast and accurate camber changes on Camaro, Firebird and Trans Am vehicles with adjustable upper strut towers.



8292

83707 Center Screw with Tip

CAUTION: Not for use with impact wrenches (air tools)

5" TIE ROD PULLER

Removes tie rod ends with a straight, fast, firm pull. Makes installation of the 87330 camber/toe kit easier (pg. 87). It has a 2-1/4" reach and a 2-1/2" spread. Also for pressing bushings.



8370



HOSE CUTTER

This high quality hose cutter provides a straight, even, clean cut on heater, air conditioning, braided rubber or plastic hose up to 1-1/8" diameter.

CUTS

- Any Plastic/Rubber Hose Up To 1-1/8" Outside Diameter
- Heater Hose
- Side Body Molding
- Windshield Channeling
- Non-Metal Air Brake Hose
- Fuel Line Hose
- Copper Wiring
- Heater Hose
- And More

10011 - REPLACEMENT BLADES 2 per pkg



10010

BUSHING PRESS SLEEVES

The sleeves are designed to match the angle of the yoke on the axle housing to insure proper installation. Use with the 72509 Ball Joint Press (page 129).

23580 - To be used with our Dodge & Jeep Offset Ball Joints (part nos. 23510, 23520, 23530, 23540 page 53).

23780 - For our Dodge Truck Offset Ball Joints (part nos. 23710 - 23730 page 53 and 23800 - 23830 page 54).



23580
23780

Tools

37000



WHEEL WEIGHT TOOL

The best tool for removing or installing passenger car and light truck wheel weights. Incorporates hooks for removal of wheel weights on many different types of wheels. Not for use on aluminum or decorative wheels.

37980



STEERING KNUCKLE TOOL

Stop damaging steering knuckles by removing linkages or struts with pry bars, screwdrivers and hammers. Use the Steering Knuckle Spreader Tool to make quick work of tight and corroded steering knuckles by simply turning the threaded wedge assembly. This is a must for any technician performing suspension work, especially for those who see the Ford Taurus or BMW passenger cars. Blow molded case included.



37985

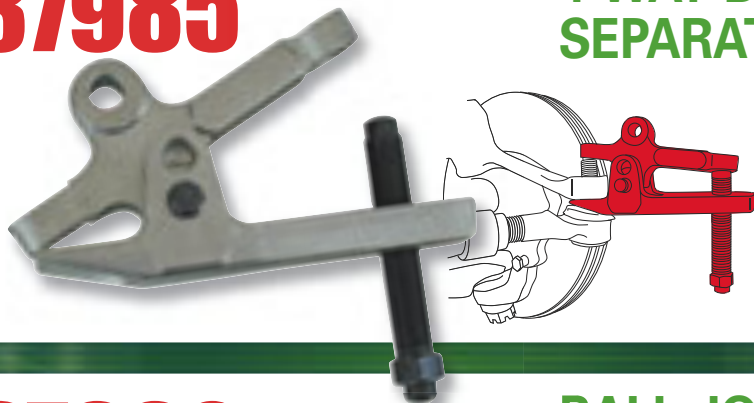

4-WAY BALL JOINT/TIE ROD SEPARATOR

This is the highest strength and most versatile Ball Joint Removal Tool on the market. The unique design of the forged 4-Way Ball Joint Separator allows the tool to be adjusted to remove ball joints of various heights, doing jobs that previously required multiple tools. Affordable, strong, and easy to use.



37990



BALL JOINT SEPARATOR

This heavy duty, drop forged alloy steel, lever-type ball joint and tie rod end remover provides good leverage action to remove stubborn tie rod ends or break ball joint tapers easily. Use when space prevents use of a direct action separator. The 37990 fits 3/4" openings.

38620

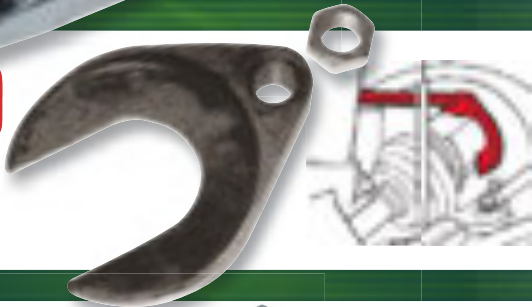

CV JOINT FORK

When used with 499 (page 122), this tool will pull most CV joints that use a hidden snap ring to hold them in the transaxle. Made to remove the axle assembly without damaging the transmission case or inside roller bearing.

40250



INTERNAL COIL SPRING COMPRESSOR

A handy chromoly steel compressor designed to fit inside most coil springs with an internally mounted shock. Will accommodate spring lengths from 8-1/4" to 14". It can be use on any coil spring with a minimum inside diameter of 3-3/8" to a maximum inside diameter of 5-5/8" and wire diameters up to 3/4". **Note: NOT for use on MacPherson struts or Fiat vehicles.**

40260

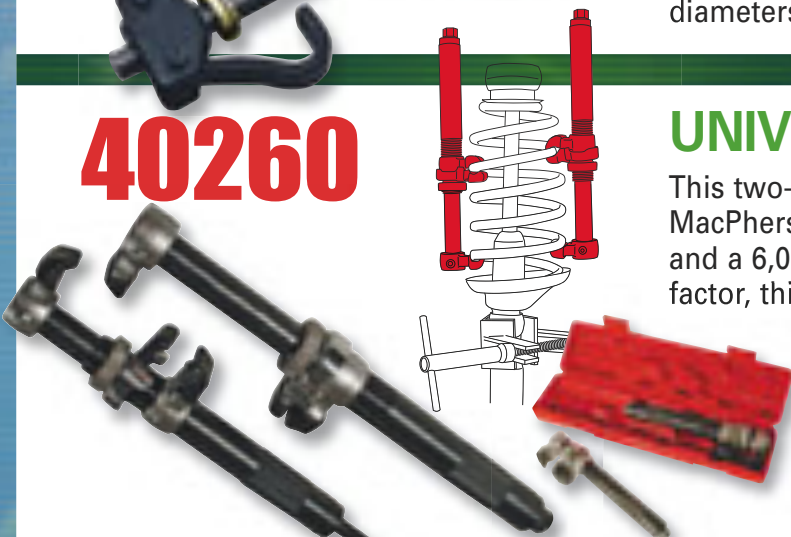

UNIVERSAL SPRING COMPRESSOR

This two-piece internally threaded spring compressor is a great option for MacPherson strut, coilover, and other accessible springs. With 7" of travel and a 6,000 lb max working load with a 3x safety factor, this is an ideal tool for almost any spring.

Vinyl coated ends protect the spring from damage, safety jaws keep the compressor stabilized on the spring, and the ball bearing load surface makes compression easy using simple hand tools. Use of both hooks per spring is required.



VALVE STEM PULLER

This easy to use valve stem puller protects the wheel and rim while you get the job done quickly. Simply screw the pivoting head onto the valve stem, slide the hard rubber protecting block to the edge of the wheel rim and remove the stem without rim scrapes or damage! Also works on 2 piece TPMS.

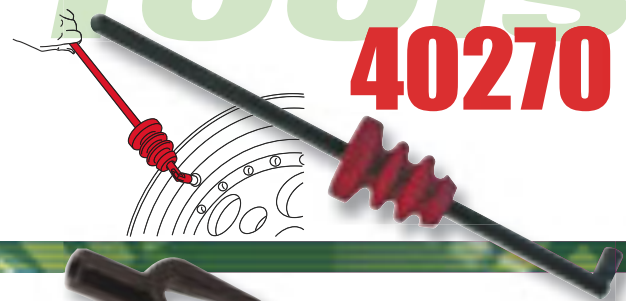

40270

TIE ROD/BALL JOINT/PITMAN ARM TOOL

Five tools in one, this handy kit consists of three drop forged forks and two handles. One handle is for use with a hammer and one is designed to fit an air hammer. All forks are threaded to interchange with either handle. Comes with 3 forks of 11/16", 15/16" and 1-1/8" openings.

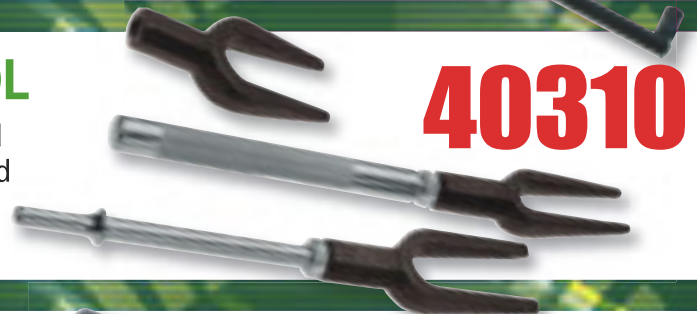

40310

TIE ROD SEPARATOR

This drop forged alloy steel tool acts as a tapered wedge and easily separates the tie rod and knuckle. Comes with a 21/32" opening and features a 16" long handle for easy access.



40340

UNIVERSAL TIE ROD ADJUSTING TOOL

This economical tool fits most cars and light trucks with split tie rod sleeves. Double-end feature makes 360 degree turns possible.



40900

Service Sets

UPPER CONTROL ARM BUSHING 40910

Easily replace press-in type control arm bushings on many domestic and imported vehicles with this service set. Mechanical power screw quickly and easily removes worn bushings and installs them without damaging the control arm. Set includes C-Frame, screw assembly and all adapters to do the job quickly and correctly. **Packaged in a durable plastic case.**

INCLUDES (See below right):

4427(3), 4428, 4429, 4430, 4431, 4432, 4433, 4434



40910

40915

40920

TOYOTA CAM EXTRACTOR 40915

Use this press tool to remove stuck OE cam sleeves from Toyota trucks. The extended length forcing screw allows you to remove the sleeve without removing the steering rack. Recommend when installing our 25430, 25435, 25440 and 25445 replacement Toyota cams (page 57).

INCLUDES (See below right): 4434, 44339



40915

PERFORMANCE BALL JOINT PRESS 40920

This tool was specifically designed to remove the original equipment ball joints on smaller cars when installing SPC Performance's sliding ball joints (pages 63 & 65). With this revolutionary design you can remove the ball joint from the front upper control arm without removing the arm from the vehicle, saving time and costs. **Packaged in a convenient blow-molded plastic case** this set comes complete with adapters for removing and installing stock or Specialty Product's sliding ball joints.

INCLUDES (See right):

4433, 4434, 40923, 40925, 40927



- 4427** U-Adapter
- 4428** 1/16" Thick Tube
- 4429** 1/18" Thick Tube
- 4430** 3/16" Thick Tube
- 4431** Forcing Head
- 4432** Receiving Socket
- 4433** Forcing Screw
- 4434** C-Frame
- 40923** Adapter
- 40925** Adapter
- 40927** Adapter
- 40929** C-Frame and Forcing Screw
- 44339** Extended Length Forcing Screw



40930



GM STRUT SET

This kit offers everything necessary for servicing GM "W" body vehicles. Kit includes strut retaining tool needed to maintain strut tube alignment with the coil spring while the strut is disassembled. Includes the tools necessary for removing and installing gas charged or oil filled strut cartridges. Lets you work through the strut tower while it is still on the vehicle. Packaged in a durable plastic case.

APPLICATIONS FWD

Buick: 1988 - 96 Regal

Chevrolet:

1990 - 01 Lumina Sedan

1995 - 99 Monte Carlo

Oldsmobile:

1988 - 97 Cutlass Supreme

Pontiac: 1988 - 96 Grand Prix

40940

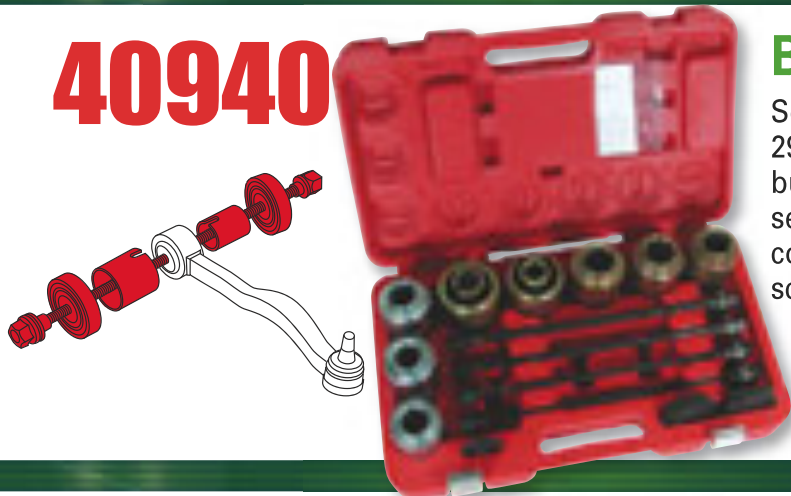

BUSHING PRESS SET (29 PIECE)

Service a wide range of bushings with this versatile press set. Our 29 piece kit will allow you to efficiently remove and install bushings form 1-1/2" to 3" OD (36 - 80mm). Save time by servicing the suspension bushing on the vehicle vs. removing components to use a shop press. The kit uses long ACME threaded screws and bearing nuts to make manual pressing a snap.

SET INCLUDES:

4 - ACME Threaded Spindles
M10 x P 1.5, M12 x P 2.0,
M14 x P 2.0, M15 x P2.5)

3 - Plate adapters
22 - 95mm Long Sleeves
Ranging in size from
34mm ID to 80mm ID

41000



DELUXE WHEEL LOCK REMOVAL SET

This set safely removes and replaces GM, Ford and Chrysler wire wheel hubcap locks on 1978 and up vehicles. Variable drive keys will also fit Corvette, McGard hubcap locks and after-market wheel lug locks. Kit comes in a durable plastic carrying case with complete instructions. Replacement parts available.

BONUS!

THIS WHEEL LOCK REMOVAL SET INCLUDES A DUAL SIDED LUGNUT REMOVAL TOOL THAT REMOVES DAMAGED OR ROUNDED O.E. STYLE LUGNUTS.

Wear appropriate eye protection when using this tool.

SET INCLUDES:

- 40008** Punch
- 40020** GM spline hubcap locks & triangular hubcap lock
- 40030** GM hubcap locks
- 40045** Stripped 18mm lugnuts/Corvette, GM N&F body wheels
- 40065** Standard McGard wheel locks/ Oversized McGard wheel locks
- 40090** Large Diameter Chrysler Lock
- 40093** Socket installing driver
- 40095** Quick-Off Lugnut Removal Tool
- 40010** Ford and Chrysler lock cylinder

41030



TIE ROD TOOL

This 1/2" drive tie rod tool will allow the easy removal of tie rod ends on most cars and light trucks. The U-shaped slot measures 1" x 3/4".

CAUTION: Not for use with impact wrenches (air tools).

41110



MASTER BALL JOINT ADAPTER SET

Expand the service capability of your ball joint press with this Master Ball Joint Adapter Set. This complete kit includes the adapters and receiving tubes needed to work on GM, Ford and Dodge two and four wheel drive trucks, vans and SUVs. Kit also includes a live center forcing screw for heavy duty applications.

REPLACEMENT PARTS AVAILABLE:

- 4159** Receiving tube - 2.87 OD x 2.62 ID
- 4415** Receiving tube - 2.50 OD x 2.25 ID
- 4416** Receiving tube - 2.0 OD x 1.75 ID
- 4417** Receiving tube - 2.5 OD x 2.25 ID
- 4418** Receiving tube - 2.13 OD x 1.80 ID
- 4419** Receiving tube - 2.5 OD x 2.25 ID x .75 AL
- 4420** Receiving tube - 2.5 OD x 2.25 ID x 2.75 AL
- 4421** Receiving tube - 3.0 OD x 2.75 ID
- 4422** Receiving tube - 2.75 OD x 2.43 ID
- 4423** Receiving tube - 2.50 OD x 2.20 ID
- 4424** Remover/Installer - 1.50 OD x .82 ID
- 4425** Installing tube - 2.0 OD x 1.82 ID
- 4426** Receiving cup - 2.12 OD x 1.75 ID

APPLICATIONS

Chevrolet 4WD:
2004 & Up Colorado

GMC 4WD:
2004 & Up Canyon

CAUTION: Not for use with impact wrenches (air tools).

COLORADO/CANYON 4WD ALIGNMENT SOCKET

45938

Aligning these trucks can be difficult because it is impossible to access the head of the cam bolt to adjust alignment angles. This special grooved socket fits over the end of the bolt allowing the technician to turn the alignment cams to change alignment angles after loosening the lock nut.



APPLICATIONS

Cadillac RWD/4WD: 2002 & Up Escalade

Chevrolet/GMC RWD/4WD:
1999 & Up 1500 & HD Crew Cab
1999 - 10 2500, 3500
2002 & Up Avalanche 1500, 2500
2004 - 13 Canyon & Colorado
2003 - Up Express/Savana Van
2000 & Up Suburban, Tahoe, Yukon, Yukon XL (1500, 2500)

Hummer AWD: 2002 - 09 H2; 2006 - 10 H3, H3T

GM TRUCK/VAN CAM ADJUSTING TOOL

45940

This wrench makes it easy to adjust the upper control arm cams on Chevrolet Express and GMC Savana vans. The tool surrounds the entire perimeter of each cam to provide a solid no-slip means to move the hard-to-reach and often rusty OEM cams.



APPLICATIONS

Chrysler: 1993 - 97 Concorde
1994 - 97 LHS, New Yorker

Dodge: 1993 - 97 Intrepid

Eagle: 1993 - 97 Vision

LH TOE TOOL

55600

This tool kit includes three tools which allow easy access and provides a much easier method for the technician to adjust toe on popular Chrysler LH body vehicles such as the Concord, New Yorker, and Intrepid.

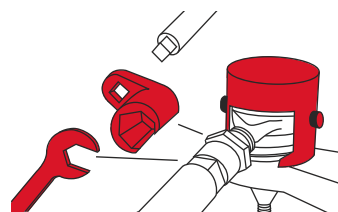

APPLICATIONS

Chrysler: 1998 - 01 LHS
1999 - 04 300M, Concorde

Dodge: 1998 - 04 Intrepid

57720 Replacement insert Kit (includes 2 inserts)

Use 23600 replacement sleeve if the sleeve is damaged (page 53).

LH TOE TOOL

55700

The newer LH vehicles use a knurled sleeve with a slot in it, threaded to the outer tie rod and inner tie rod to adjust toe. Often the sleeve is hard to turn because of corrosion on the threads. Conventional toe-adjusting tools can damage the original sleeve. This tool will help prevent damage to the sleeves and inner bushings while making adjusting the toe easier and quicker.

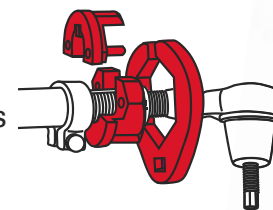

MAGNETIC ANGLE GAUGE

This angle gauge is an easy, accurate way for measuring frame and drive shaft angles. An ideal tool to ensure the drive line angle is still within specification for raised and lowered vehicles. **Alignment equipment manufacturers are using frame angle input with their software for completing Caster specifications.**

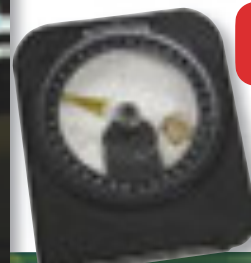
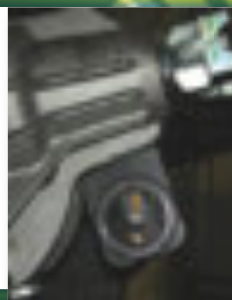

64225

APPLICATIONS

Acura: 1994 - 01 Integra

Honda:
1988 - 00 Civic
1988 - 92 CRX
1992 - 97 Del Sol



HONDA BUSHING EXTRACTOR

65100

Easily and quickly remove and install rear trailing arm bushing in as little as 15 minutes per side vs. the factory "book" time of 1.8 hours per side. No need to remove the trailing arm from the vehicle or use a hydraulic press.

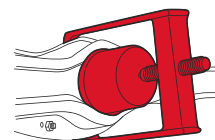

66025



CHRYSLER BUSHING PRESS SLEEVES

These adapter sleeves are designed to be used with the **40920** Performance Ball Joint Press (page 125). It is designed specifically to remove the stock rear control arm bushings and to install our Offset Rear Camber Bushings, Part No. 66050 (page 60) used on the newer Chrysler LX platform cars.

67647



SUBARU/SCION TOE PRESS ADAPTER

The OE rear toe link bushing on the Subaru WRX can be easily removed when using the 67647 Bushing Press Adapter. Our Eccentric Toe Bushings (part #67660 page 70) can then be installed using the adapter and a **72509** Ball Joint Press (pg 129), **40920** Performance Ball Joint Press (pg 125), or equivalent.



68670



REMOVABLE CUTTER ROTOR-BOR

Air drill driven tool made to cut out the spot welds holding the original equipment alignment plate to the top of strut towers. Once the plate is loosened caster and camber can be adjusted. Sold with 3/8" and 5/16" removable cutters. Use our "Cool Tool" cutting fluid, **85774** (page 133), for longer cutter life.

68750

Replacement cutters (3) - 3/8"

68780

Replacement cutters (3)- 5/16"

CAUTION: Always wear safety glasses when using cutting or grinding tools and equipment.

68880 68890



CHRYSLER SOCKETS

These sockets are used on Chrysler products with screw in ball joints. They have a 3/4" square drive and are four-point, a perfect fit for our ball joints on page 91.

APPLICATIONS

68880 - 1-29/32" opening for Plymouth/Dodge

68890 - 2-1/8" opening for Chrysler

69330



HONDA CLEARANCE ARM SOCKET

This special 10 point socket is needed when removing the O.E. rear lower control arm on new 2001 to 2006 Honda Civics, 2003 and up Elements, 2002 to 2006 CRVs and 2002 to 2007 Acura RSXs. Included with Part No. **69300** and **69400** (page 71).

71909 TIE ROD TOOL KIT

This kit includes part numbers 71959 through 71999. It will allow adjustment of most cars and light trucks and also includes the two larger adjusting tools needed for the new Ford Super Duty pickups. Tools have a 1/2" drive opening that allows the use of a ratchet or breaker bar. Kit comes with a protective carrying case.

71959, 71969, 71979 TIE ROD TOOLS

These tie rod tools spread the tie rod adjusting sleeve for easier adjustment. You can use these tools with a breaker bar for additional power. With 1/2" drives.

71989, 71999 FORD SUPER DUTY TOOLS

These are the tools needed to adjust toe on the new Ford Super Duty Pickups. With 1/2" drives.

71909 SET INCLUDES:

71959, 71969, 71979, 71989, 71999

71959

3/4" opening for compact cars

71969

7/8" opening for standard cars

71979

1-1/8" opening for light trucks

71989

1-7/16" opening for adjusting the center link sleeve on Ford Super Duty Trucks

71999

1-13/16" opening to adjust the drag link sleeve on Ford Super Duty Trucks

CAUTION: Not for use with impact wrenches (air tools).

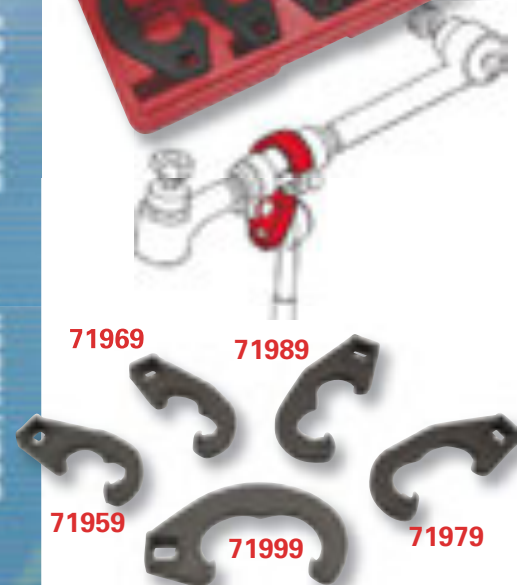

APPLICATIONS

BMW: SPC Kits #72065, #72070, #72080, #72090, #72180, #72190
Mini Cooper: SPC Kit #72620

FRONT STRUT TOOL

This tool was designed for turning the valves on adjustable damping struts when our SPC Adjustable Strut Mounts are used on BMWs (pg. 74 & 76) and Mini Coopers (pg. 69).



72095



RWD/4WD BALL JOINT PRESS

Remove and replace ball joints without "brute force" methods that can cause costly damage. Now you can take on 4WD ball joint service in addition to servicing most cars. A forcing screw-powered press, used with proper adapters, easily removes and installs all press-fit ball joints (inc. GM plastic pin "U" type joints). In a durable plastic case.

72509

PACKAGE INCLUDES:

- 4437** Press
- 4438** Forcing Screw
- 29503** Receiver Tube, 3" OD x 2-3/4" ID
- 29504** Receiver Tube, 2-1/2" OD x 2-1/4" ID
- 29505** Receiver Tube, 2" OD x 1-3/4" ID
- 38354** 4WD Receiving Cup
- 38355** Installing Cup
- 204508** 4WD Installing Adapter
- 305227** Installing Adapter
- 305228** Removing Adapter



NOTE: Lubricate before use.

CAUTION: Not for use with impact wrenches (air tools).

1-1/8" PUNCH

This tool is used to cut holes necessary to install our **83115** (page 82) camber kits. A must to ensure a good, round hole.



73010

PITMAN ARM PULLER

Designed to handle the toughest job, the **73119** is adjustable and has special forged jaws shaped to fit the job. Positive grip allows this tool to do many other pulling jobs.

CAUTION: Not for use with impact wrenches (air tools).



73119

74400 1-1/2" Open End
 For **24160** - Holds outer bushing body and for **24180** - Holds inner eccentric sleeve.

74500 1-1/4" Box End
 For **24120, 24130, 24180** - Adjusts the inner sleeve.

ADJ. SLEEVE WRENCHES

These wrenches make presetting our adjustable truck sleeves (page 55) easier for the installer. When using the **74400** wrench it is recommended that the opening be equally positioned over the slot opening of the sleeve body.



74400 74500

APPLICATIONS

Cadillac RWD/4WD:
 1999 - 01 Escalade
Chevrolet/GM RWD/4WD:
 1988 - 00 1500, 2500, 3500
 1992 - 94 Blazer (Full Size)
 1996 - 02 Express & Savana Van
 1988 - 91 Jimmy (Full Size)
 1992 - 99 Suburban
 1995 - 99 Tahoe
 1992 - 99 Yukon
Chevrolet/GM AWD:
 1990 - 01 Astro & Safari Van
Jeep RWD/4WD:
 2007 & Up Wrangler (JK)

KNOCK OUT PUNCH

A necessary tool for removing the alignment inserts on the upper control arm alignment brackets without damaging the bracket. Includes a center punch for the older GM vehicles and newer Jeep JKs and an offset punch for GM's newer models.

- 74914** - Replacement Offset Punch.
- 74915** - Replacement Center Punch.

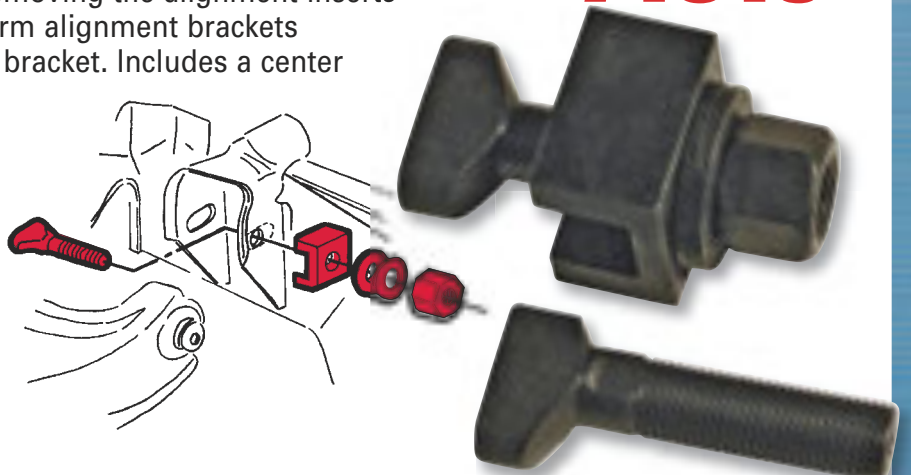

74910

Tools

Torque Stix

These Torque Stix are low cost and efficient. There is nothing to calibrate or maintain and the end result is properly torqued wheels and satisfied customers who demand properly torqued lug nuts. Vehicle torque specification chart (#70050 below) included in sets.

76610-76655

INDIVIDUAL TORQUE STIX - 1/2" DRIVE

PART NO.	COLOR	DESCRIPTION	PART NO.	COLOR	DESCRIPTION
76610	green	17 mm nut, 45 ft. lbs. torque	76615	red	17 mm nut, 80 ft. lbs. torque
76620	yellow	19 mm nut (3/4"), 65 ft. lbs. torque	76625	blue	19 mm nut (3/4"), 80 ft. lbs. torque
76630	grey	19 mm nut (3/4"), 100 ft. lbs. torque	76635	brown	13/16" nut, 100 ft. lbs. torque
76640	black	21 mm nut, 60 ft. lbs. torque	76645	orange	21 mm nut, 80 ft. lbs. torque
76665	purple	17 mm nut, 110 ft. lbs. torque			Mercedes 1994 & Up C Class, S Class, R Class, M Class
Light Truck Torque Stix					
76650	white	7/8" nut, 120 ft. lbs. torque	76655	aqua	7/8" nut, 140 ft. lbs. torque

76660

FORD SUPER DUTY TORQUE STIX - 1/2" DRIVE

13/16" 160 ft. lbs. - vanilla - 1/2" drive Torque Stix for: 1999 & Up Ford Super Duty trucks and 2000 - 2005 Excursions.

76670 FORD HD F150 - 1/2" DRIVE

21mm 150 ft. lbs. - turquoise - 1/2" drive Torque Stix for: 2000 - 04 Ford HD F150/Expeditions with a 12mm nut 2000 & Up Ford HD F150 and Expeditions with 14mm nut.

76760 DODGE TRUCK TORQUE STIX

15/16" 135 ft. lbs. - green - Torque Stix with 1/2" drive for: Dodge BR2500 and BR3500 Pickups.

76700, 76800, 76900 1/2" DRIVE SETS

76700 four piece set includes: 76625, 76630, 76635, 76650.

76800 eight piece set includes: 76610, 76615, 76620, 76625, 76630, 76635, 76645, 76650.

76900 ten piece set includes: 76670, 76615, 76620, 76625, 76630, 76635, 76675, 76645, 76650, 76655.

75500 4 PIECE TORQUE EXTENSION SET

Use your own 1/2" drive impact sockets with these torque stix extensions. An economical choice to achieve accurate torque settings. **75500** four piece set includes:

PART NO.	COLOR	DESCRIPTION	PART NO.	COLOR	DESCRIPTION
75520	yellow	65 ft. lbs. torque	75530	grey	100 ft. lbs. torque
75525	blue	80 ft. lbs. torque	75550	white	120 ft. lbs. torque

75555 HEAVY DUTY EXTENSION

Heavy duty aqua extension for 140 ft. lbs. torque. 1/2" drive compliments **75500** set.

75560 FORD SUPER DUTY EXTENSION

160 ft. lbs. - orange - 1/2" drive extension for: 1999 & Up Ford Super Duty trucks and 2000 - 2005 Excursions.

75580, 75585 HEAVY DUTY EXTENSIONS

75580 1" drive heavy duty extension 400 ft. lbs. - yellow

75585 1" drive heavy duty extension 550 ft. lbs. - yellow



- Fits 95% of passenger and light truck applications.
- Helps prevent broken or damaged studs.
- Helps prevent damage to alloy wheels.
- Helps prevent distortion of rotors, drums, wheels.

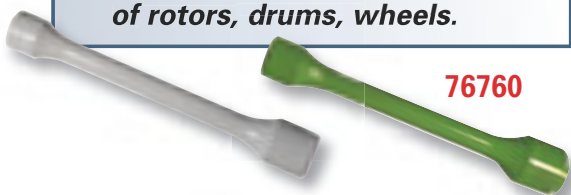

76760



75500



75560

75555

75585

75580

70050 TORQUE STIX CHART

Find out your correct torquing specs quickly and easily with this handy chart.



1-800-525-6505

Call for your nearest distributor, product info or Technical Assistance • In the USA and Canada

www.specprod.com



EZ SHIM™ CUTTER

This cutter, a must for properly cutting our patented EZ Shim™ (page 78), is a great tool for a variety of cutting needs. Its thin cutting blades help prevent breakage and waste.



75915

HONDA ADAPTERS

Honda Adapter #75980 is used in conjunction with the 72509 Ball Joint Press (page 129) and are used with the 67465 Honda Civic Camber Kit on page 67. You need these adapters to push the old bushing out of the stock arm and also to install the new bushing included in the 67465 Kit.



75980

MERCEDES PRESS SET

The 75990 Mercedes Rear Bushing Press Adapter Set is designed for quick, easy removal of the OE rear control arm bushings and for the insertion of new adjustable camber bushings. This tool set is a must for any shop servicing Mercedes vehicles, and includes a wrench for easy adjustment of the 28840 rear bushing (page 57).



75990

CAUTION: Not for use with impact wrenches (air tools).

GM INNER TIE ROD CRIMPER

When changing GM inner tie rod ends, the installer must "crimp" the new tie rod onto the rack. This tool makes the job easy and locks the tie rod end on the rack without excessive force on the rack seals.



77210

FORD SUPER DUTY TIE ROD SLEEVE ADJUSTER

This tool is specifically designed for use on the Ford Super Duty trucks as well as most other light trucks and vans as well. The extra long bar gives you maximum leverage to loosen rusted sleeves without injuring your knuckles. This 8 position tool allows 360° rotation without removing the adjuster block from the sleeve.



77350

APPLICATIONS

Dodge: 2500 & 3500

Ford: Twin I-Beam w/upper and lower ball joints

CAUTION: Not for use with impact wrenches (air tools).

FORD/DODGE COMBO SLEEVE PULLER

This sleeve puller will pull both O.E. and most aftermarket camber/caster sleeves quickly and efficiently, usually without damaging the ears of the sleeve. Heat treated high strength steel. Single-unit design with no loose parts.



77880

APPLICATIONS

Saturn: 1991- 02 S-Series

SATURN TOE TOOL

The leverage this tool provides to move the rear control arm makes it easy to accurately adjust toe on early Saturn vehicles.



78090

DEEP, THIN WALL FLIP SOCKETS

These 1/2" square drive impact sockets are deep and thin walled to reach areas conventional sockets can't reach. Each part numbers provides two sizes.

79230: 3/4" and 13/16"

79240: 19mm and 21mm



79230
79240

GM BUSHING PRESS SLEEVES

These adapter sleeves are designed to be used with the 72509 Ball Joint Press (page 129). They are designed specifically for easy removal of the stock bushing and installation of the 86330 and 86350 Offset Upper Control Arm Bushings (page 85) used on 1988 and newer GM light trucks.



79500

81139

MAGNETIC ADJUSTABLE CAMBER GAUGE

The 81139 is inexpensive, portable, and very accurate. It has a simple leveling adjustment of $\pm 3^\circ$. Housed in a durable, non-magnetic casing with a magnetic head that attaches firmly to rotors or spindles.

81134 - Replacement Bubble Vial.

81133 - Replacement Magnet.



- Time/money saving device.
- Return a strut to its original camber after repair or replacement.
- Measure amount of camber change movement before reinstalling alignment heads during camber kit installation.
- Check the amount of camber change before reinstalling tire and wheel assemblies on trucks receiving offset alignment bushings.

81309

STEEL WHEEL RIM STRAIGHTENING TOOL

For quick and easy removal of indentations on wheel flanges and rims of most vehicles. Allows proper tire seating, giving greater tire protection and durability. This tool is powder coated for added durability.



83125

HEAVY DUTY WHEEL WEIGHT TOOL

This heavy duty wheel weight tool has a special grip hammer and pliers for removal and installation of truck wheel weights. If you are using steel wheel weights, instead of lead wheel weights, this is the tool for you!



83775

GM ALIGNMENT TOOL

This tool allows for fine, accurate, easy adjustments of camber or caster on GM vehicles. No extra parts or cutting/ grinding needed.



APPLICATIONS

Adjust front camber/caster

Cadillac: 2003 - 08 CTS/CTS-V
2004 - 09 SRX

Chevrolet: 1993 - 02 Camaro

Pontiac: 1993 - 02 Firebird, Trans Am

Adjust rear toe

Buick: 1979 - 93 Riviera

Cadillac: 1980 - 92 Eldorado, Seville

Oldsmobile: 1978 - 92 Toronado

83785

GM CAMBER/CASTER TOOL

Save time and make adjusting front camber and caster a one-person job on popular GM platforms with this turnbuckle design tool. Simply attach the tool to the front lower control arms and dial in finite changes on GM mid-size SUV's, the Chevy SSR and the Cadillac CTS/CTS-V

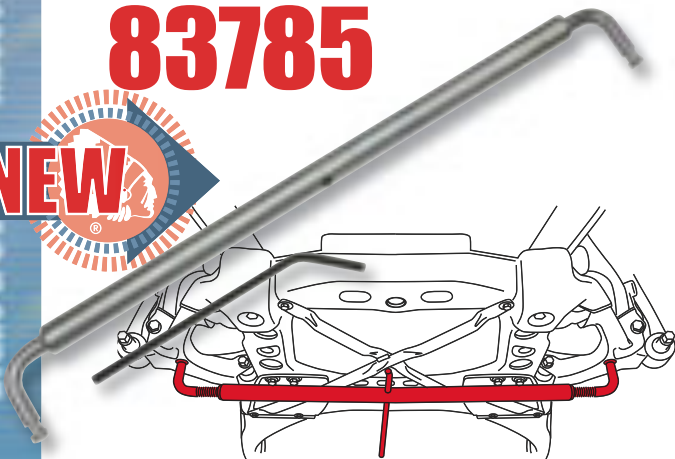

APPLICATIONS

Buick: 2004 - 07 Rainer

Cadillac: 2003 & Up CTS, CTS-V
2005 - 11 STS
2004 - 09 SRX

Chevrolet: 2004 - 06 SSR
2002 - 09 Trailblazer

GMC: 2002 - 09 Envoy

Isuzu: 2003 - 07 Ascender

Oldsmobile: 2002 - 04 Bravada

Saab: 2005 - 09 9-7X

83820

FORD SUV CAM ADJUSTING WRENCH

This wrench is specifically designed to adjust the **86640** Camber/Caster Kit (page 86). This steel wrench is plated for durability.



APPLICATIONS

Ford RWD/4WD:

2003 - 06 Expedition

Lincoln RWD/4WD:

2003 - 06 Navigator

1-800-525-6505

Call for your nearest distributor, product info or Technical Assistance • In the USA and Canada

www.specprod.com



APPLICATIONS

- Buick:** 1988 - 04 Regal
- Cadillac:** 2004 - 09 SRX
- Chevrolet:** 1990 - 01 Lumina Sedan
1995 - 99 Monte Carlo
- Oldsmobile:**
1988 - 97 Cutlass/Supreme
- Pontiac** 1995 - 96 Grand Prix

GM REAR TOE TOOL

83850

Tool allows quick, precise, and profitable adjustments of rear toe on both left and right sides of GM vehicles.



Rotary Files

STEEL FILE SET 85125

High quality carbide rotary files, ideal for elongating strut holes on many vehicles. Use when installing **82110**, **82120**, and **87350** adjusters. May be used with 1/4" or 3/8" drills at high speeds. Available individually. Use with **85774** Cool Tool cutting fluid (below).

INCLUDES:

- 85126** - 1/4" Rotary File (Max. Operating Speed 9,000 RPM)
- 85127** - 3/8" Rotary File (Max. Operating Speed 9,000 RPM)
- 85128** - 5/8" Rotary File (Max. Operating Speed 7,000 RPM)



3/8" ROTARY FILE SET 85130

This rotary file set is ideal for every technician. Be ready to elongate slots in Aluminum and Steel frames and brackets to accept larger offset cams. The kit includes one 85127 rotary file for steel, one 85137 rotary file for aluminum, and cutting fluid (85774) to extend your rotary file's life.

ALUMINUM FILE 85137

This 3/8" rotary file is specifically designed for Aluminum. Use it to quickly and cleanly expand cam slots in aluminum brackets and frames. It is an ideal tool to use when installing SPC Nissan and Infiniti Cams (pages 73 and 76). Also is perfect when installing our Mustang Caster Bolts (page 77) and our Ford Crown Vic Front Cam Kit (page 87). Use with **85774** Cool Tool cutting fluid (below).



COOL TOOL FLUID 85774

This fluid lubricates the **85125** Rotary File Set (above), and the **68670** Rotor-Bor (page 122) to reduce stress on the cutting teeth. This product is **highly recommended** to prolong the life of all cutting bits used on steel.

CAUTION: Always wear safety glasses when using cutting or grinding tools and equipment.

85774

APPLICATIONS

- Ford:** 1986 - 07 Taurus Sedan/Station Wagon
1994 - 03 Windstar
- Mercury:** 1986 - 07 Sable Sedan/Station Wagon
2004 - 07 Monterey

CAUTION: Always wear safety glasses when using cutting or grinding tools and equipment.

FORD 3/8" DIAMETER ROTOR-BOR

85790

Use this air drill driven tool to cut out the spot welds holding the original equipment alignment plate to the top of the strut tower of all Taurus/Sable/Windstar/Monterey vehicles. Once the plate is loosened caster and camber can be adjusted.

857901 Replacement Cutter



CAUTION: Not for use with impact wrenches (air tools).

3-IN-1 SPINDLE PULLER

85796

85796 is a 3-in-1 puller that makes removing the spindle from four wheel drive vehicles much easier. This puller fits spindle sizes 1-1/2", 1-5/8" and 2" spindles that are O.E. on 4x4 trucks.



Tools

87130
87135

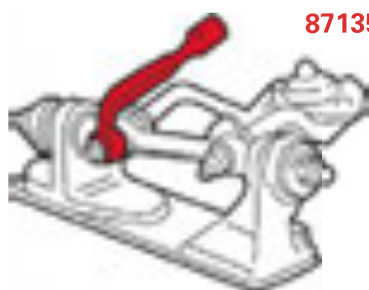

87135



87130

MINI VAN CAMBER/ CASTER WRENCHES

These wrenches are designed specifically to make front wheel alignments faster and easier. By fitting the upper control arm bolts, these wrenches can fine tune camber and caster adjustments on Ford Aerostars & GM Astro Vans and older RWD pickups.

APPLICATIONS

87130 -13/16"
Ford: 1986 - 97 Aerostar Van

87135 -3/4"
Chevrolet/GMC RWD:
1985 - 05 Astro/Safari Van
1973 - 87 C10, C15

CAUTION: Not for use with impact wrenches (air tools).

87175



TRUCK SLEEVE SOCKET

This 1-1/2" socket is useful for adjusting both the OEM and our popular **23130** and **23180** sleeve series (see pages 51 and 52) for Ford and Mazda RWD and 4WD trucks with pinch bolt style suspension. For 1/2" drives.

APPLICATIONS

Dodge RWD: 1994 - 99 3500 Ram w/Mono
Dodge 4WD: 1994 - 99 2500HD, 3500 Ram
Ford RWD: 1990 - 90 Bronco II (Late 90)
1992 & Up E150, E250, E350, E450
2000 - 05 Excursion; 1987 - 96 F150
1998 - 13 F250, F350 Twin I-Beam
1987 - 98 F250, F350
Ford 4WD: 2000 - 05 Excursion
1999 - 04 F250, F350 Solid Axles/Leaf Springs
1992 - 98 F350 Crew Cab
Ford RWD/4WD: 1999 - 04 F450, F550
1991 - 94 Explorer

87320

NEW



FORD/MERCURY REAR BUSHING ADJUSTING TOOL

Many popular Taurus/Sable sedans utilize our 87330 Rear Camber/Toe Kit (page 87). The new 87320 Bushing Adjustment Tool allows easy access to the head of the eccentric bushing to ease adjustment.

APPLICATIONS

Ford:
1986 - 07 Taurus Sedans
Mercury:
1986 - 07 Sable Sedans

87325



TAURUS & TEMPO REAR TOE WRENCH

This tool allows quick, precise, and profitable adjustments of O.E. rear toe on both sides of Ford and Mercury Sedans.

APPLICATIONS

Ford: 1986 - 07 Taurus Sedan
1986 - 94 Tempo Sedan
Mercury: 1986 - 07 Sable Sedan; 1986 - 94 Topaz Sedan

87530



VW SHIM WRENCH

Designed to remove the rear hub when installing our **71520** and **71530** Series Volkswagen shim (page 72). This wrench is a must in assisting the installer when using these camber and toe shims.

87560

NEW

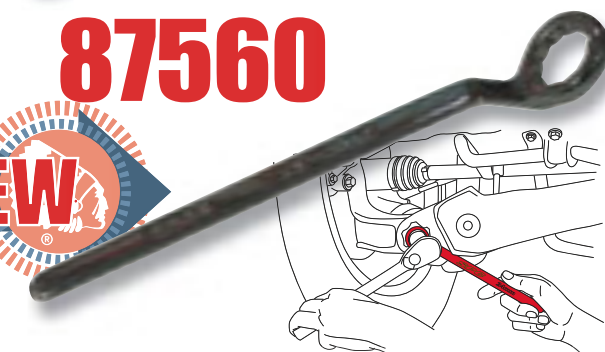

HONDA 24MM TOE ADJUSTING TOOL

This tool makes rear toe adjustment easy on many late model Hondas. The 24mm wrench can also be used on the new Acura ILX and Mini Coopers.

APPLICATIONS

Acura: 2013 & Up ILX
Honda: 2006 & Up Civic
2007 & Up CR-V
2003 - 11 Element
Mini Cooper:
2002 & Up Cooper/Cooper S,
Conv., Clubman

1/2" Drive

APPLICATIONS

- Ford:** 1992 - 02
Crown Victoria
- Lincoln:** 1991 - 02 Town Car
- Mercury:** 1992 - 02
Grand Marquis

CAMBER/CASTER WRENCH

88325

This unique camber and caster adjustment tool fits full size RWD Ford vehicles. Starting in the early 90s Ford RWD vehicles required rotating a separate cam for each angle adjustment. To adjust caster/camber use the **88325** wrench to rotate the cam. This wrench also holds the cam to prevent slipping when tightening the lock nut.

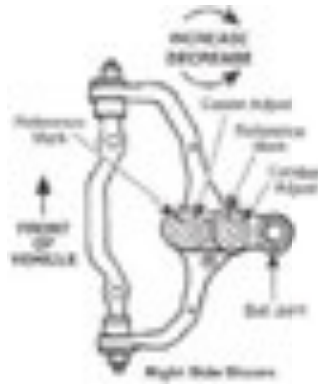

APPLICATIONS

- Dodge RWD/4WD:**
2008 & Up 4500, 5500
- Sterling Bullet RWD/4WD:**
2008 - 11 4500, 5500

DODGE PIN JOINT ADJUSTING WRENCH

88360

The 2-3/8" flat hex wrench is designed to make the installation of the **23852** and **23854** (page 54) Dodge pin joints quicker and easier. Use a 1-1/2" socket to hold your adjustment and then tighten the jam nut with this tool.



CAUTION: Not for use with impact wrenches (air tools).

88830 is not recommended for use on Ford Motor Co. original equipment sleeves. Use 77880 (page 131) for O.E.M. Sleeves.

FORD/DODGE SLEEVE PULLER (AFTERMARKET)

88830

This puller is designed to work specifically with the **23100** and **23120** sleeves. It will allow the technician to pull the sleeves without normally breaking the ears off the sleeve.



89105 – Dual socket inner tie rod removal tool, fits 1-3/16" or 1-5/16" hex. inner tie rod ends on Fords and Chryslers with TRW racks.

89106 – A 1-3/16" hex. tool for inner tie rod ends on Ford Escort, Tempo, Topaz, Lynx.

89107 – A 1-5/16" hex. tool designed for inner tie rod ends on 1986 & up Taurus/Sable.

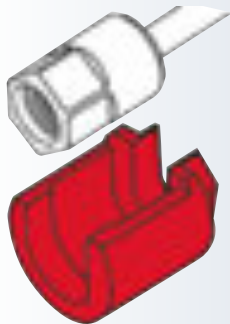

89108 – A 1-7/16" hex. tool designed for GM Saginaw rack and pinions.



INNER TIE ROD END WRENCH SET

89000

Set includes the **89105** Dual Socket Inner Tie Rod Removal Tool along with the **89106**, **89107** and **89108** adapter sockets. Also available individually.

CAUTION: Not for use with impact wrenches (air tools).



89105



APPLICATIONS

- Ford:** 1986 - 05 Taurus Station Wagon
- Mercury:** 1986 - 05 Sable Station Wagon

FORD STATION WAGON REAR TOE TOOL

97650

Ford Taurus and Mercury Sable Station wagons have a sprocket type cam to adjust rear toe. This tool engages the sprockets and allows the technician to turn the cam for required adjustment.



Tools

91000
91010
91025

FASTRAX™ CAMBER / CASTER GAUGE

This great tool is a must for all garages and shops - plus, it can't be beat at the track.

Portable, hands-free alignment can be done quickly and easily with the **FasTrax™ Adjustable Camber/Caster Gauge**. This tool will help you fine tune your alignment for optimal tracking and handling while minimizing alignment headaches.

- Includes gauge and wheel mount.
- Displays Camber $\pm 4^\circ$ / Caster -4° to $+12^\circ$.
- Saves time and tires.
- Accurate, rugged and easy-to-use



91000



91000
w/91100

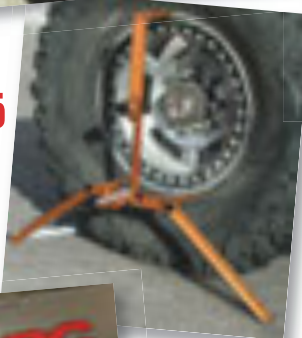

91025



91010

91000 Standard - Fits wheels 13" to 17"
Optional Toe Adapter Kit (91100) sold below.

91010 Performance - Fits wheels 17" - 22"
Optional Toe Adapter Kit (91100) sold below.

91025 Off-Road - Fits Wheels 13" to 17"
Align off-road wheels - tire sizes up to 44".
Includes longer toe arms, bungie cord & tape measure.

91030 No lip adapter
A quick adapter to attach the FasTrax to wheels without an outer "lip". Fits on the 91000, 91010 and 91025.

91040 Heavy Duty - Fits Wheels 21" to 26"
Perfect to add to your PMs -
Check your alignment in just 5 minutes. Includes extra length toe arms, heavy duty tape measure and no lip adapters.



91040
See Page
104 for more



91025

91030

If you do any of these jobs at your garage - you need the FasTrax Camber/Caster Gauge!

- Install adjustable control arms
- Replace idler arms / tie rod ends
- Replacing struts
- Install adjustable bushings
- Collision repair estimates
- Frame straightening

We have a FasTrax for your use:

- Garage
- Racing
- Performance
- Off-Road
- Muscle
- Semi's



91100



FASTRAX™ TOE ADAPTER SET

Simply lower the toe arms and insert tape measure into slot. Then measure to opposite tire reference point for accurate and fast toe readings. Includes 2 arms and reinforcement blocks that install easily onto either the 91000 or the 91010.

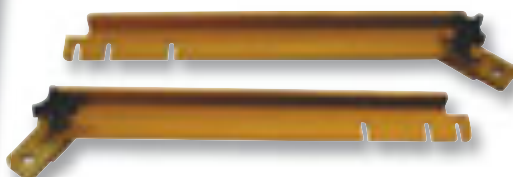

For more convenience we recommend using two FasTrax with Toe Adapters (use one on each side of the vehicle).

1-800-525-6505

Call for your nearest distributor, product info or Technical Assistance • In the USA and Canada

www.specprod.com



WHEEL ALIGNMENT GAUGE

Features the broader ranges (Caster +14°/-6°, Camber +8°/-8°, SAI +20°/-20°) necessary in today's new vehicles. This gauge is made with precision workmanship and quality materials. The housing is made of durable die cast aluminum. The multi-pole ALIGNCO MAGNET, with built-in cutting teeth, removes burrs on the hub surface. Levels are recessed to prevent breakage. Can be used with #91088 below.

OPTIONAL ADAPTER: 99961 - Adapter for mid & full-size cars.



99684

ADAPTER FOR MAGNETIC ALIGNMENT GAUGES

Fits all cars and light trucks with wheel diameters up to 20 in. This rim adapter is used when the hub is inaccessible. The adapter easily attaches to the rim, using built-in thumb screws, to provide a machined surface for accurate measurement of caster, camber and steering axis inclination (use with 99684 (above) caster/camber gauge).



91088

WHEEL SPREADER

Take the play out of front wheels during alignment! Place this spring-loaded pressure bar between the tires to assure a more accurate alignment. **A must for Mercedes vehicles.**

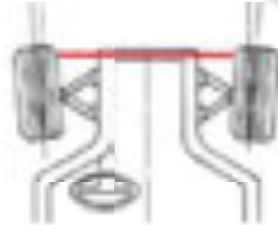

99918

APPLICATIONS

99361 extends 46-74 in. for light trucks & cars.

99374 extends 39-60 in. for standard and compact cars.

TOE MEASURING GAUGES

Spring-loaded gauges easily adapt to a variety of tread widths in order to give fast, accurate toe readings.



99361
99374

77928 BRAKE PEDAL DEPRESSOR

An adjustable steel plate extends the length of the bar to put constant pressure on the brake pedal.



77938

CAUTION: This product is not a locking device. Use only according to directions packaged with product.

77938 STEERING WHEEL HOLDER

A must for proper alignments. This tool securely holds the steering wheel and covered hooks and base prevent damage to the steering wheel or seat.



77928

77928
77938

CAUTION: Use only according to directions packaged with product.

APPLICATIONS

Cars and light trucks

DIMENSIONS

11" x 15-1/2" x 2"

Weight Limit: 5,000 lbs/wheel

Range: 100°

TURNTABLES (PR)

99750 is full floating with enclosed ball bearings. Large, easy to read dial is quickly adjusted to zero. Ideal for racks, pits, floor units or stands (**99884** - next page). **Sold in pairs.**
PT-0750-14 - Replacement bearings



99750

Accessories

99884



FRONT WHEEL STANDS (PR)

Made of heavy gauge steel, these portable stands will enable the wheel alignment mechanic to perform alignments without an alignment rack. Designed to be used with 99750 turntables (optional). All legs have leveling adjustments. **Sold in pairs.**

DIMENSIONS

Base: 20-3/4" x 16-3/4"
Top: 15-1/2" x 11-3/4"
Height: 15-1/2" (with WA750 turntables)
Weight: 17 lbs. (Each)
Weight Limit: 2,500 lbs/wheel

99886



REAR WHEEL STANDS WITH SLIP PLATES (PR)

Portable stands allow technicians to perform alignments without an alignment rack. Use with 99884 Front Wheel Stands, all legs have leveling adjusters. **Sold in pairs.**

DIMENSIONS

Top: 13-1/4" x 10-1/2"
Height: 15-1/2"
Weight: 28.5 lbs. (Each)
Weight Limit: 2,500 lbs/wheel

91851



REAR SLIP PLATES (PAIR)

With a total height of only 3/8", these low-profile slip plates allow a 2 inch total movement of the rear wheel while adjusting camber and toe. **Sold in pairs.**

DIMENSIONS

11-1/2" x 17-3/4" x 3/8"

99511

99512

99548



WA5119
11"
Pointer

99511 &
99548

WA515-9L
17" Pointer

99516

99512

99511 TOE BAR WITH SCRIBE

Gives toe readings (in 1/32 of an inch increments) by measuring distances between marks scribed at the center of the tire treads. Comes with 8 ft. bar, 11 in. pointers, 5 in. stands, and 99516 (below) scribe.

99512 TOE BAR WITH SCRIBE

Complete with 8 ft. bar, 17 in. pointers, 5 in. stands, and 99516 (below) scribe.

99548 TOE BAR WITH SCRIBE

Same as 99511 except with a 4 ft. bar with a 50mm gauge, and 99516 scribe.

99511

APPLICATIONS
Cars and light trucks

99512

APPLICATIONS
Trucks, buses, vans and RV's

99548

APPLICATIONS
Honda ATVs, Yamaha ATVs

POINTERS

WA5119 11" Pointer

WA515-9L 17" Pointer

99516



SCRIBE ASSEMBLY











Included with all the toe bars shown above (99511, 99512, 99548). This scribe is ideal for use with any style of toe measuring bar.

PT0500-01 - Replacement Pin.

Do you specialize in Heavy Duty Trucks or maintain a truck fleet?
Check out our complete Heavy Duty Truck Section on pages 101-111



Carbide Brake Lathe Inserts

Brake Lathe Models	SPC Part #	Per Pack	OEM Part #	Cutting Edges	Description	Bits - Actual Size
Accu-Turn 8911,8922, 8944, 8989, 8991, 8993	06005	5	433795	3	Positive rake carbide bit.	
	06010	10	433796	3		
All Tool 747	06506 06510	6 10		3 3	Positive rake carbide bit.	
Ammco 1000,1001,3000,4000, 4100,7000,7700, On-vehicle lathe 700,705,710 Drum side on 3850	06202 06206 06210	2 6 10	6914-2 6914-6 6914-10	12 12 12	Negative rake carbide bit.	
	06610	10		12-18	Round bits for round tool holders.	
3850,4000,7000,7500 6900,6950 Twin cutter/9381 Grinding Set	10306	6	7681-6	3	Positive rake carbide bit	
FMC- John Bean/ Barrett 67BSD,67DLX,67GSA, 69DLX,701ECF,601PF FMC or Barrett 400,500,700 500 Series On-The-Car Lathe 500 Series On-The-Car Lathe	40702 40706 40710	2 6 10	90487 90488	3 3 3	Positive rake carbide bit with .020 radius. Left and right hand tool holders.	
	10306	6	91212	3	Positive rake carbide bit.	
	06202 06206 06210	2 6 10	90817	3 3 3	Negative rake carbide bit.	
Hofmann/ RJ West True-Cut 400/401 660	40702 40706 40710	2 6 10	722-83-4	3 3 3	Positive rake carbide bit.	
	06202 06206 06210	2 6 10	6914-2 6914-6 6914-10	12 12 12	Negative rake carbide bit.	
Hunter BL500 / BL505 201,205	06506 06510	6 10	221-583-3	3	Positive rake carbide bit. For Rotors.	
	70210	10	V302-07-167	12	Negative rake carbide bit.	
Kwik-Way SDL,DL,850 Disc Lathe,NDL, BDL, CBL Kwi-Lathe On-The-Car #108-0005-04 ROTUNDA, LINE-O-TRONICS	80206 80210	6 10	109-1092-23	3 3	Positive rake carbide bits for rotor and drum.	
Performance 66, 6600, 7100, 7200, 7600	06506 06510	6 10	8711 8711	3 3	Positive rake carbide bits for rotor and drum.	
Perfect Equipment 400 & 450 Twin Turn	40702 40706 40710	2 6 10	W139	3 3 3	Positive rake carbide bit.	
Pro-Cut 610 On-The-Car Lathe 610 On-The-Car Lathe	06906 06910	6 10	50-741 50-742(8)	3 3	Positive rake carbide bit for Ford.	
	70606	6	50-701	3	Positive rake carbide bit.	
Rels SW504 Swing Arm 204C, 204D, 204S, 205DC, 415 2000	80206 80210	6 10	SW4236-15	3 3	Positive rake 15 degree carbide bit.	
	90310	10	29687V	3	Positive rake carbide bit.	
	06202 06206 06210	2 6 10	45001	12 12 12	Negative rake carbide bit.	
RTI BRC500,BRC550 BRC35 On-The-Car Lathe	10306	6		3	Positive rake carbide bit.	
Snap-On YA180,YA281	80206 80210	6 10	BTK10A	3	Positive rake carbide bit.	
Van Norman 204S Old Style, 205DR, 301, 303, 304, 305, 310, 404, 404,4 05 243XV, 204C, 204D, 204S, 205DC, 415	90203	3	302167	2	Positive rake parallelogram drum bit.	
	90310	10	129687 866561	3	Positive rake bit.	
VGB 610 On-The-Car Lathe	70606	6		3	Positive rake carbide bit.	

Tech Tip: Positive rake bits usually have 3 cutting edges, have a tapered shape to them, and are installed on a flat tool holder. Negative rake bits can have 12 cutting edges, are square with the edges, and are used with an angled tool holder.

SPC Part #
90203

00191

RIGHT HAND TOOL HOLDER

Fits **AMMCO** Model 7000 Disc Rotor Lathe; 3000, 4000, 4100 Drum Lathes and **HOFFMAN** Model 660. Complete with one Carbide Insert No. 062.



3/8" Square Shank

00404

RIGHT HAND TOOL HOLDER

Fits all **FMC/JOHN BEAN** Brake Lathes and **ACCU-TURN**. Complete with 1 Carbide Insert No. 407. **FMC/JOHN BEAN, ACCU-TURN**



3/8" Square Shank

00192

LEFT HAND TOOL HOLDER

Fits **AMMCO** Model 7000 Disc Rotor Lathe; 3000, 4000, 4100 Drum Lathes and **HOFFMAN** Model 660. Complete with one Carbide Insert No. 062.



3/8" Square Shank

00405

LEFT HAND TOOL HOLDER

Fits all **FMC/JOHN BEAN** Brake Lathes and **ACCU-TURN**. Complete with 1 Carbide Insert No. 407. **FMC/JOHN BEAN, ACCU-TURN**

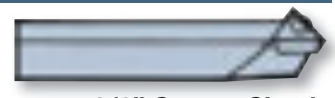

3/8" Square Shank

06700

RIGHT HAND AND LEFT HAND TOOL HOLDERS

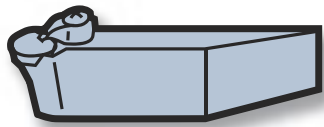

3/8" Square Shank

Fits **ALL TOOL, AMMCO, HUNTER, PERFORMANCE,** and **RELS.** Complete with Carbide Insert No. 06610. Number 06700 includes 2 holders, one right hand and one left hand, with one left and one right bit.

Rotor Silencers



00050

00050

ON CAR BRAKE LATHE SILENCER

Designed for **Pro Cut** on car lathes, this silencer fits on top of the cutting tools, deflecting chips and damping chatter.



00069

00069

VENTILATED DISC SILENCER

Fits any ventilated rotor and is made of natural rubber with lead weight inserts. It easily wraps around rotor to deaden vibration and chatter.

DIMENSIONS: 32" long.



00070

00070

BENCH BRAKE LATHE SILENCER

This standard style silencer fits on top of the cutting tools, deflecting chips and damping chatter.

00080



00080

DRUM SILENCER

00080 drum silencer fits any passenger car drums. Made of natural rubber. It wraps around the drum and is secured with a buckle.

DIMENSIONS: 1-3/4" wide, 72" long

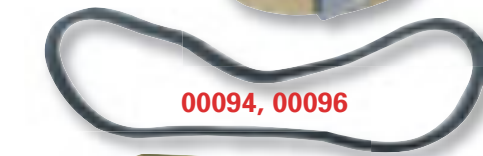

00094, 00096

00094, 00096

SILENCER BANDS

Large and small black rubber gasket-type silencer bands for solid rotors.

DIMENSIONS: **00094:** - 1/4" x 3/8" x 9" diameter

00096: - 1/4" x 3/8" x 6-1/2" diameter



00095, 00195

00095, 00195

VENTILATED ROTOR DISC SILENCERS

Used on any brake lathe and with any ventilated rotor, they suppress vibration and noise. Segmented silencer is made of the finest latex rubber tubing with four (4) steel tubes to quiet chatter. Recommended for all disc resurfacing machines.

DIMENSIONS: **00095:** - 10" diameter

00195: - 7" diameter

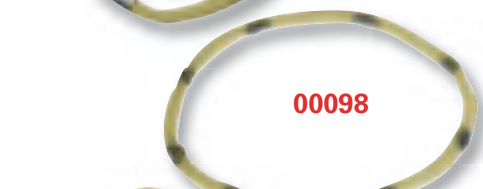

00098

00098

ADJUSTABLE VENTILATED ROTOR SILENCER

This adjustable silencer is made of latex tubing with lead weight implants.

DIMENSIONS: 32" long

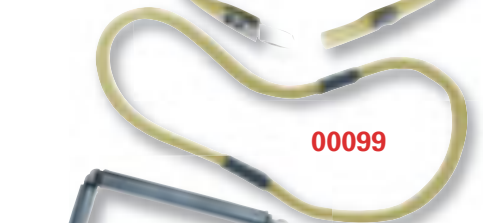

00099

00099

ELASTIC ADJUSTABLE SILENCER

Dampen chatter, noise and vibration on solid and vented rotors.

DIMENSIONS: 3/16" x 3/8" x 6-3/4" diameter. Stretches to 19" diameter



09800

09800

SPRING LOADED SILENCER

Replacement for **Ammco 9800** Spring Loaded Silencer

Brake & CV

DISC BRAKE PADS (PAIR)

Made of a tough friction substance, these replacement pads easily snap onto the **AMMCO 7075** Disc Rotor Silencer. They are very good for thin, non-vented type rotors on many import cars.

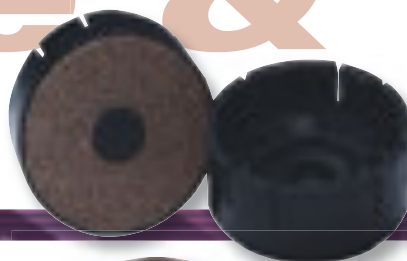

00083

GRINDING PADS

These non-directional pads help produce a smooth finish on machined rotors. Replacement for **AMMCO 8756** pads. Adhesive mounting; 4" diameter; set of six.



00989

00991 – (Set of 10) - Fine Replacement Pads

00992 – (Set of 10) - Coarse Replacement Pads

SWIRL GRINDER

Non-directional hand held swirl finishing tool puts the required finish on your rotors. Lightweight aluminum handle with knurled grip makes a job fast and easy. Velcro-type mount, 4" diameter head.



00999

LATHE KNOB

Replacement knob for **AMMCO** Lathes (1 each).



06854

GAUGE FOR RUN-OUT SETS

This replacement gauge fits our stand-alone run out gauge (#64250 - below).



33174

- Measures out of round condition which can cause front end vibration
- Pinpoints high and low spots in the tire

Tire Radial Run-Out



- Measure kingpins ball joints, and tie rod end axial & radial play
- Extender rods for hard to reach areas

Suspension / Ball Joint Play



- Check for bent or out of round wheels
- Out of round wheels may cause a shimmy condition

Wheel Lateral Run-Out



- Measure brake rotor high spots and out of round
- Measure hub radial play

Brake Rotor and Hub Run-Out



RADIAL RUN-OUT GAUGE

64250

Radial run-out is an out of round condition in which the radius of the wheel or tire is not consistent from the wheel center to any point on the rim or the tread. Tire and wheel radial run-out are often factors in troubleshooting ride and handling and in maintaining correct wheel balancing to reduce vibration.

Includes:

- Heavy duty tripod
- Wide machined roller
- Accurate pin-pointer
- Ball joint/tie rod extenders



Includes ball joint/tie rod extenders

Please refer to Specialty Products Wheel Alignment Specifications Book (part #82012) for ball joint specifications.



02099



CV BOOT CLAMP INSTALLATION TOOL

Designed for the low-profile clamps used to hold C.V. Boots on FWD vehicles. The 02099 comes complete with a ratchet. We recommend using this tool when installing our 87365 Crown Victoria Camber Kit (page 87).



33001

UNI-FIT CV SOLID REPLACEMENT BOOT

Manufactured of Neoprene, the boots are resistant to oil, grease, water, drying, abrasion, and tearing. They are easy to install and fit most front wheel drive passenger cars and light trucks. Each kit includes boot, OE type grease, universal clamps, and easy installation instructions. One size fits most cars.

This patented Conicalution™ design features continuously rounded fluting that evenly distributes stress and reduces boot wear.



- Rapid Turnover
- Reduces Inventory
- Simple to Catalog
- Easy Ordering
- Never Obsolete
- Saves Space
- Durable
- No Mix-ups

33053, 33054 BOOT CLAMPS

Stainless steel replacement bands in 2 lengths for securing the 33001 Uni-Fit boot.

33053 – (Set of 10) - 8 in. 33054 – (Set of 5) - 19 in.

33060 BOOT CLAMP SET

Stainless steel replacement bands in 2 lengths for securing the 33001 Uni-Fit boot packaged on an easy to inventory card. Contains one each - 8 in. & 19 in.



Use our #02099 Boot Clamp (above) Installation Tool to make tightening these clamps easy!

32012

UNI-FIT REPLACEMENT BOOT ECONOMY PACK (SET OF 12)

The Economy Pack is ideal for the shop that wants to save inventory dollars. Bulk buying saves you time and money by having the lowest possible price boots waiting on your shelf. No more waiting for delivery service, no missed sales.

PACKAGE INCLUDES EVERYTHING NEEDED FOR CONTINUOUS SERVICE:

Use our #02099 Boot Clamp (above) Installation Tool to make tightening these clamps easy!

33001 - Uni-Fit CV Boots (12), Grease tubes (12), 18-1/2 in. Stainless steel bands (12), 7-1/2 in. Stainless steel bands (12), Instruction sheets.

33020

UNI-FIT STEERING BOOT (PAIR)

This one-size fits-all Uni-Fit rack & pinion boot has been supplied throughout the world since 1981. It is made of durable, neoprene material that is oil, grease and water resistant. The kit includes two boots and two clamps to service both sides of the rack.

World Application Wheel Alignment Catalog (part #20019)

Printed in three languages, English, Spanish and French, this comprehensive alignment catalog features our most popular parts, tools, accessories used in the world market.

Applications for many European, Asian and Latin American specific vehicles are available in our easy to use make/model year format. The catalog also contains all of our North American applications, making this the perfect publication for French and Spanish speaking techs in the United States, Canada and Mexico.



HEAVY DUTY WHEEL CENTERING TOOLS COUNTER MAT

Create extra sales at the counter with this great teaching tool from SPC. This high quality, foam backed mat explains the problems caused by off-centered wheel and the benefits of using our Wheel Centering Sleeves. 11" x 17"



20106

"WHY DO YOU NEED A PROPER ALIGNMENT?" COUNTER MAT

Sell more alignments to your customers with this high quality counter mat which explains tire wear problems, alignment angles along with solutions and benefits of a proper four wheel alignment. This **2 sided** mat has English on one side and Spanish on the other. 11" x 17"



20107

"WHY DO YOU NEED A PROPER ALIGNMENT?" POSTER

All the information from our popular Alignment Counter Mat (#20107), but in a large poster size. Perfect for fitting into standard retail store frames, this poster is a great selling tool for the front of your store. 22" x 35"



20108

Don't forget all our installer training options - check out page 3 or go online to www.specprod.com/training. We have the most up-to-date training available in the alignment field, from on-line courses to in-depth training at our corporate office.



SIZES

PERFORMANCE - CREAM COLOR SHIRT

63000M Medium

63000L Large

63000XL Extra Large

63000L X-Extra Large

INDIAN HEAD LOGO - BLACK COLOR SHIRT

63010M Medium

63010L Large

63010XL Extra Large

63010XXL X-Extra Large

SPC PERFORMANCE GOLF SHIRT

High quality cream colored shirt with SPC Performance red logo embroidered on the front.



63000

TRADITIONAL GOLF SHIRT

High quality black golf shirt with our traditional 'Indian Head' logo embroidered on the front.



63010

63004



SPC PERFORMANCE SEW-ON PATCH

White patch, 2" x 3.5", embroidered with the SPC Performance logo in red. Perfect for sewing onto jackets, racing suits and more!

63007



SPC PERFORMANCE BALL CAP

Great looking ball caps with SPC Performance embroidered on the front. Navy, mid profile, with a red and white SPC Performance logo. One size fits all.

66010 66070



SPC NYLON JACKETS

These jackets are great for light outdoor wear. Our traditional 'Indian Head' logo is available stitched on a black/white jacket as well as on a tri-color red/white/black jacket. *Note: Jacket availability may be different than pictured.*

SIZES

INDIAN HEAD LOGO - TRI COLOR JACKET

66010M Medium

66010L Large

66010XL Extra Large

INDIAN HEAD LOGO - BLACK/WHITE JACKET

66070M Medium

66070L Large

66070XL Extra Large

Save Your Box Tops - Earn Great Gear!



For each box top you send in you can earn great SPC Gear or VISA® Debit Cards. You can also earn entries into our quarterly contests where you can win a \$250 VISA® Debit Card or our Grand Prize - **a trip for 2 to the SEMA show in Las Vegas.** Call customer service at 800-525-6505 for more!

66020



SPC MECHANIC'S GLOVE

Gloves with a synthetic leather palm and Spandex padded top for form-fitting durability featuring reinforced thumb, index finger and fingertips with contact points for improved handling of objects.

SIZES

66020S Small

66020M Medium

66020L Large

66020XL Extra Large

66065 64005



SPECIALTY PRODUCTS COMPANY T-SHIRTS

Take your choice from two heavy duty t-shirts.

Choose from a classic black 'tee' with our Indian Head logo printed on the front, or our SPC Performance 'tee' with an SPC logo on the front and a full color performance vehicle graphic on the reverse.

SIZES

INDIAN HEAD LOGO -

66065M Medium

66065L Large

66065XL Extra Large

66065XXL X-Extra Large

SPC PERFORMANCE - BLACK W/ FULL COLOR PRINTING ON BACK

64005M Medium

64005L Large

64005XL Extra Large

64005XXL X-Extra Large

DIMENSIONS

- 67001** White cut vinyl - SPC Performance - 2" x 6"
- 67002** Red printing on White Base - SPC Performance - 1.5" x 5"
- 67003** White Windshield Decal SPC Performance - 4" x 39"
- 67008** SPC Performance Bumper Sticker - Red/Black 2.25" x 8.5"

SPECIALTY PRODUCTS/ SPC PERFORMANCE VINYL

Vinyl stickers that proclaim you have the best in suspension parts. These stickers look great whether you use them for your windshield, bumper, side window or just to put on your tool box.



67001
67002
67003
67008

88033 INSTALLER BANNER

2' x 4' white banner/red & black lettering with grommets. This banner is perfect for letting your customers know that you install only the best - SPC Performance.

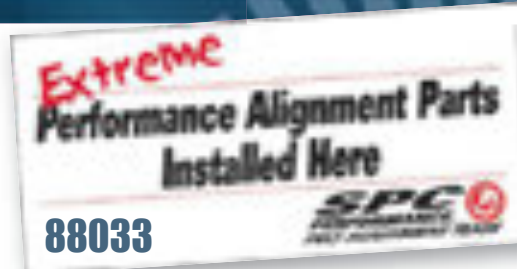

88033
88035
88036

88035 TRADITIONAL BANNER

3' x 8' white banner/red & black lettering with grommets. Show your customers you deal with the best - Specialty Products Co.



88035

88036 PERFORMANCE BANNER

No hiding with this 3' x 5' white banner. Red SPC Performance lets everyone know that you have the best in performance tuning alignment parts.



88036

SPC Knows Performance

Circle Track

Innovative products that give you a true advantage in your chassis set up, handling and performance. Our fully adjustable arms are designed for use on many stock or tube framed chassis for circle track, road racing and quarter mile. Components available to custom fit any chassis.



Muscle Car, Street Rod & Strip

Entire suspension solutions for muscle cars or street rods. Fully adjustable, rugged upper control arms, custom designed lower control arms to improve your tracking and handling, coil springs that provide optimum rates for unsurpassed performance along with spindles, components and more!

Sport Compact/ Road Race

SPC Performance is the world leader when it comes to performance suspension tuning. With cutting edge designs and over 35 years experience, SPC alignment kits are recognized for top quality and largest adjustment ranges. Whether you are road racing on the weekend, building an ultra high end show car or professionally drifting your ride, our parts have been there and have what it takes to win.



NUMERICAL INDEX

NUMERICAL INDEX & RETAIL PRICING (U.S. DOLLARS)

Item	Page	Pop†	MSRP	Item	Page	Pop†	MSRP	Item	Page	Pop†	MSRP	Item	Page	Pop†	MSRP	Item	Page	Pop†	MSRP
27	122	T	40.95	1705	96	SP	26.75	4437	129	T	133.30	10306	139	T	69.48	10553	103	W	97.15
498	122	T	70.62	1706	96	D	29.82	4438	129	T	87.42	10403	103	SP	69.37	10554	103	SP	338.60
498-1	122	T	54.42	1714	96	SP	23.15	6140	123	T	152.38	10404	103	SP	170.60	10562	103	SP	61.92
498-2	122	T	16.67	1716	96	SP	24.52	7023	123	T	49.63	10405	103	W	46.67	10563	103	W	103.27
498-3	122	T	1.92	1718	96	SP	26.75	8286	123	T	106.28	10408	103	C	12.73	10564	103	SP	276.03
499	122	T	117.25	1724	96	SP	24.08	8292	123	T	73.67	10412	103	B	48.18	10572	103	SP	63.75
499-1	122	T	51.70	1726	96	SP	25.27	8370	123	T	135.38	10413	103	SP	77.08	10573	103	W	105.63
499-2	122	T	43.95	1728	96	SP	26.75	00050	140	T	78.48	10414	103	SP	183.07	10574	103	SP	364.27
499-3	122	T	1.92	1817	96	SP	25.25	00069	140	T	45.58	10422	103	W	49.40	10598	103	SP	94.67
499-4	122	T	30.05	1818	96	SP	26.75	00070	140	T	61.82	10423	103	SP	77.97	10603	103	C	91.07
1102	96	SP	19.27	1819	96	SP	29.85	00080	140	T	48.53	10424	103	SP	253.63	10604	103	SP	319.58
1103	96	SP	21.78	1903	96	W	29.82	00083	141	T	24.20	10432	103	W	49.73	10605	103	SP	68.30
1104	96	SP	23.18	1905	96	W	32.58	00094	140	T	9.58	10433	103	SP	84.37	10612	103	W	70.40
1105	96	SP	24.52	1906	96	D	35.92	00095	140	T	53.38	10434	103	SP	213.63	10613	103	C	95.92
1106	96	W	26.75	2006	96	SP	25.45	00096	140	T	8.52	10442	103	B	51.67	10614	103	W	208.25
1303	96	SP	20.55	2007	96	SP	26.82	00098	140	T	38.10	10443	103	SP	85.25	10622	103	W	73.07
1502	96	SP	15.82	2008	96	SP	32.82	00099	140	T	16.85	10444	103	SP	207.97	10623	103	C	104.08
1503	96	SP	18.92	2009	96	SP	34.18	00191	140	T	35.97	10452	103	W	52.03	10624	103	W	254.25
1504	96	SP	23.18	2012	96	SP	24.52	00192	140	T	35.97	10453	103	SP	87.82	10632	103	W	78.45
1505	96	SP	23.15	2013	96	SP	26.73	00195	140	T	43.20	10454	103	SP	239.08	10633	103	C	105.55
1506	96	SP	26.75	4159	126	T	52.80	00404	140	T	36.62	10462	103	SP	54.25	10634	103	SP	255.88
1512	96	SP	16.85	4169	123	T	36.42	00405	140	T	36.62	10463	103	SP	91.63	10642	103	SP	81.08
1513	96	SP	20.55	4415	126	T	34.85	00989	141	T	16.05	10464	103	SP	231.25	10643	103	C	112.73
1514	96	SP	20.55	4416	126	T	39.37	00991	141	T	26.42	10472	103	SP	55.15	10644	103	SP	261.37
1515	96	SP	23.15	4417	126	T	33.10	00992	141	T	26.42	10473	103	SP	94.22	10652	103	W	82.55
1516	96	SP	26.75	4418	126	T	26.77	00999	141	T	181.38	10474	103	SP	266.73	10653	103	C	122.37
1602	96	SP	29.82	4419	126	T	14.70	02099	142	T	80.47	10503	103	W	71.70	10654	103	SP	298.33
1603	96	SP	32.58	4420	126	T	34.85	06005	139	T	23.28	10504	103	SP	191.15	10662	103	SP	84.25
1614	96	SP	34.60	4421	126	T	34.20	06010	139	T	44.23	10505	103	SP	49.73	10663	103	C	130.60
1615	96	SP	29.82	4422	126	T	34.20	06202	139	T	7.57	10512	103	W	51.27	10664	103	SP	402.60
1616	96	SP	32.55	4423	126	T	57.80	06206	139	T	20.37	10513	103	W	77.45	10672	103	SP	88.15
1617	96	SP	24.07	4424	126	T	19.85	06210	139	T	29.37	10514	103	SP	258.00	10673	103	C	133.48
1618	96	SP	25.15	4425	126	T	35.05	06506	139	T	32.92	10522	103	W	53.00	10674	103	SP	365.85
1619	96	W	26.75	4426	126	T	25.52	06510	139	T	50.90	10523	103	W	81.70	10698	103	SP	96.18
1620	96	W	29.82	4427	125	T	17.05	06610	139	T	63.90	10524	103	SP	281.37	10703	103	B	97.67
1621	96	W	29.82	4428	125	T	12.80	06700	140	T	151.38	10532	103	W	55.33	10704	103	W	221.33
1622	96	W	26.75	4429	125	T	12.80	06854	141	T	3.72	10533	103	W	87.52	10705	103	B	73.27
1627	96	D	28.45	4430	125	T	12.80	06906	139	T	36.48	10534	103	W	265.60	10712	103	B	81.08
1628	96	C	29.82	4431	125	T	31.08	06910	139	T	56.03	10542	103	W	57.22	10713	103	B	108.60
1702	96	SP	20.55	4432	125	T	50.00	09800	140	T	74.47	10543	103	W	91.33	10714	103	W	246.45
1703	96	SP	23.18	4433	125	T	42.92	10010	123	T	47.03	10544	103	SP	285.70	10722	103	B	81.75
1704	96	SP	24.55	4434	125	T	110.20	10011	123	T	17.43	10552	103	W	59.67	10723	103	B	114.33

† POPULARITY CODES = A, B, C, D, W, X - STANDARD POP CODES • T - TOOL • SP - SPECIAL ORDER
 PRICING EFFECTIVE 7/1/2013 • PRICING SUBJECT TO CHANGE • FOR CURRENT PRICING CALL 800-525-6505

NUMERICAL INDEX & RETAIL PRICING (U.S. DOLLARS)

Item	Page	Pop†	MSRP	Item	Page	Pop†	MSRP	Item	Page	Pop†	MSRP	Item	Page	Pop†	MSRP	Item	Page	Pop†	MSRP
10724	103	C	228.70	15110	117	SP	52.30	15835	121	SP	32.09	23130	51	SP	304.18	23229	52	C	31.67
10732	103	B	83.18	15115	117	SP	52.26	15840	121	SP	42.79	23131	51	C	33.82	23231	52	C	31.67
10733	103	B	124.85	15120	117	SP	42.16	15850	121	SP	74.91	23132	51	A	33.82	23232	52	C	31.67
10734	103	D	246.07	15125	117	SP	42.19	15860	121	SP	107.05	23133	51	A	33.82	23233	52	C	31.67
10742	103	C	87.55	15130	117	SP	60.36	15865	121	SP	117.76	23134	51	A	33.82	23234	52	C	31.67
10743	103	B	134.03	15140	117	SP	56.61	15870	121	SP	192.74	23135	51	A	33.82	23235	52	C	37.73
10744	103	D	299.85	15150	117	SP	56.51	15875	121	SP	235.56	23136	51	A	33.82	23236	52	C	37.73
10752	103	C	92.45	15160	117	SP	56.91	15880	121	SP	289.11	23137	51	A	33.82	23237	52	C	37.73
10753	103	B	144.55	15170	117	SP	45.51	15885	121	SP	374.80	23138	51	B	33.82	23238	52	C	37.73
10754	103	D	311.85	15440	117	SP	96.34	15890	121	SP	460.49	23139	51	C	33.82	23239	52	C	34.22
10762	103	W	96.82	15442	117	SP	117.76	20106	106	SP	14.95	23160	51	X	138.37	23268	52	C	46.92
10763	103	B	148.07	15445	117	SP	58.85	20107	143	SP	14.95	23161	51	X	17.30	23269	52	C	46.92
10764	103	W	408.58	15450	117	SP	40.41	20108	143	SP	4.95	23162	51	X	17.30	23410	53	C	186.93
10772	103	W	99.73	15455	117	SP	37.44	21020	96	SP	17.33	23163	51	X	17.30	23510	53	B	125.60
10773	103	B	160.33	15460	117	SP	32.09	21030	62	SP	51.93	23164	51	X	17.30	23520	53	B	125.60
10774	103	W	477.58	15465	117	SP	26.71	21080	49	SP	24.97	23165	51	X	17.30	23530	53	B	125.60
10782	103	W	111.52	15474	117	SP	33.15	23002	50	SP	26.00	23166	51	X	17.30	23540	53	C	125.60
10783	103	B	179.12	15475	117	SP	33.15	23004	50	W	26.52	23167	51	X	17.30	23580	123	T	87.82
10798	103	SP	99.82	15476	117	SP	43.86	23006	50	W	26.52	23168	51	X	17.30	23600	53	C	40.52
15010	117	SP	42.14	15477	117	SP	43.86	23008	50	D	26.52	23180	52	SP	178.93	23710	53	W	196.52
15012	117	SP	42.14	15478	117	SP	59.94	23010	50	W	26.52	23181	52	A	19.88	23720	53	W	196.52
15015	117	SP	29.41	15479	117	SP	61.00	23012	50	D	26.52	23182	52	A	19.88	23730	53	W	196.52
15018	117	SP	32.09	15480	117	SP	104.90	23100	50	SP	310.33	23183	52	A	19.88	23755	53	B	54.37
15020	117	SP	29.26	15481	117	SP	105.99	23101	50	B	34.48	23184	52	A	19.88	23765	53	B	54.37
15022	117	SP	56.85	15482	117	SP	144.54	23102	50	A	34.48	23185	52	A	19.88	23780	123	T	103.77
15024	117	SP	56.85	15483	117	SP	144.54	23103	50	A	34.48	23186	52	A	19.88	23800	54	C	187.22
15028	117	SP	29.26	15510	116	SP	19.24	23104	50	A	34.48	23187	52	A	19.88	23810	54	C	187.22
15032	117	SP	32.09	15515	116	SP	103.81	23105	50	B	34.48	23188	52	A	19.88	23820	54	C	187.22
15040	117	SP	30.96	15605	116	SP	31.19	23106	50	A	34.48	23189	52	A	19.88	23830	54	C	187.22
15042	117	SP	41.21	15607	116	SP	31.19	23107	50	B	34.48	23190	52	A	19.88	23850	54	W	187.22
15045	117	SP	25.70	15609	116	SP	49.95	23108	50	A	34.48	23191	52	A	21.82	23852	54	W	187.22
15050	117	SP	20.30	15611	116	SP	49.95	23109	50	A	34.48	23192	52	A	21.82	23854	54	W	187.22
15055	117	SP	18.36	15613	116	SP	31.19	23111	50	C	34.48	23193	52	B	21.82	23940	54	W	196.82
15060	117	SP	17.61	15615	116	SP	31.19	23112	50	A	34.48	23194	52	A	21.82	23960	54	SP	196.82
15065	117	SP	17.00	15617	116	SP	37.44	23113	50	B	34.48	23199	52	C	19.88	24120	55	C	46.75
15080	117	SP	66.71	15619	116	SP	49.95	23120	51	X	304.18	23211	52	C	37.73	24130	55	A	46.75
15082	117	SP	66.71	15625	116	SP	TBA	23121	51	X	33.82	23212	52	B	37.73	24160	55	C	60.48
15085	117	SP	66.71	15627	116	SP	TBA	23122	51	X	33.82	23221	52	B	31.67	24180	55	A	46.75
15087	117	SP	66.71	15629	116	SP	TBA	23123	51	X	33.82	23222	52	B	31.67	24220	55	B	58.63
15090	117	SP	60.00	15631	116	SP	TBA	23124	51	X	33.82	23223	52	B	31.67	24230	55	C	66.45
15092	117	SP	59.95	15635	116	SP	TBA	23125	51	X	33.82	23224	52	A	31.67	24640	96	SP	20.97
15095	117	SP	60.00	15637	116	SP	TBA	23126	51	X	33.82	23225	52	B	34.22	24650	96	W	20.97
15097	117	SP	60.00	15639	116	SP	TBA	23127	51	X	33.82	23226	52	B	34.22	24690	96	W	20.97
15100	117	SP	51.90	15810	121	SP	337.14	23128	51	X	33.82	23227	52	B	34.22	24700	96	W	20.97
15105	117	SP	51.95	15815	121	SP	645.69	23129	51	X	33.82	23228	52	B	34.22	24701	96	W	20.97

† POPULARITY CODES = A, B, C, D, W, X - STANDARD POP CODES • T - TOOL • SP - SPECIAL ORDER
 PRICING EFFECTIVE 7/1/2013 • PRICING SUBJECT TO CHANGE • FOR CURRENT PRICING CALL 800-525-6505



www.specprod.com

Call for your nearest distributor, product info or
 Technical Assistance • In the USA and Canada

1-800-525-6505

NUMERICAL INDEX & RETAIL PRICING (U.S. DOLLARS)

Item	Page	Pop†	MSRP	Item	Page	Pop†	MSRP	Item	Page	Pop†	MSRP	Item	Page	Pop†	MSRP	Item	Page	Pop†	MSRP
24740	96	W	20.97	25732	120	SP	TBA	32131	106	SP	69.15	35041	102	A	44.92	36091	102	W	44.67
24750	96	W	20.97	25734	120	SP	TBA	33001	142	D	26.22	35042	102	A	49.00	36092	102	W	49.82
24751	96	W	20.97	25740	120	SP	2,348.35	33020	142	C	32.18	35050	102	W	40.48	37000	124	T	25.30
24790	96	W	20.97	25742	120	SP	1,111.59	33053	142	SP	16.40	35051	102	W	42.93	37100	58	W	15.82
24800	96	C	20.97	25744	120	SP	1,248.94	33054	142	SP	19.48	35052	102	W	45.27	37101	58	W	17.85
24850	96	C	20.97	25746	120	SP	916.44	33060	142	SP	7.12	35060	102	A	14.25	37102	58	D	22.30
24900	96	C	20.97	25750	120	SP	2,028.11	33105	108	T	111.70	35061	102	A	15.93	37103	58	D	22.30
24950	96	C	20.97	25760	120	SP	2,219.64	33130	107	SP	49.95	35062	102	A	17.33	37104	58	W	16.03
24960	96	SP	20.97	25762	120	SP	1,185.55	33131	107	SP	49.95	35070	102	W	48.08	37105	58	D	17.85
24970	96	SP	20.97	25764	120	SP	1,041.94	33132	107	SP	56.75	35071	102	W	50.92	37106	58	C	20.08
25430	56	SP	58.42	25780	120	SP	2,038.94	33133	107	SP	63.08	35072	102	W	53.82	37107	58	B	24.27
25435	56	SP	58.42	25784	120	SP	859.24	33134	107	SP	78.58	35075	57	W	29.30	37150	58	W	162.63
25440	56	SP	58.42	25790	120	SP	2,321.66	33140	107	SP	112.03	35076	57	C	29.30	37980	124	SP	97.30
25445	56	SP	58.42	25792	120	SP	1,188.95	33141	107	SP	114.77	35077	57	W	49.85	37985	124	SP	83.30
25460	56	SP	918.73	25794	120	SP	1,148.94	33142	107	SP	120.13	35080	57	W	19.15	37990	124	T	36.05
25465	56	SP	TBA	25824	120	SP	1,349.49	33143	107	SP	117.48	35081	57	W	19.15	38354	129	T	134.57
25470	56	W	880.27	25830	120	SP	2,263.59	33144	107	SP	120.13	35082	57	W	19.15	38355	129	T	116.63
25480	56	W	880.27	25832	120	SP	1,171.55	33145	107	SP	114.77	36000	101	W	797.70	38620	124	T	42.00
25485	56	SP	918.73	25834	120	SP	1,101.10	33146	107	SP	120.13	36001	102	W	74.15	40008	126	T	6.95
25490	56	SP	984.70	25850	120	SP	2,952.60	33147	107	SP	114.77	36002	102	W	78.00	40010	126	T	31.43
25501	119	SP	112.66	25852	120	SP	1,706.40	33148	107	SP	128.28	36003	102	W	82.18	40020	126	T	31.43
25505	119	SP	31.34	25854	120	SP	1,268.19	33149	107	SP	128.28	36010	102	W	52.15	40030	126	T	31.43
25508	119	SP	69.14	25860	120	SP	2,432.91	33171	107	T	9.47	36011	102	W	53.75	40045	126	T	41.00
25515	118	SP	10.70	25862	120	SP	1,349.05	33172	107	T	9.47	36012	102	W	56.70	40065	126	T	48.25
25520	118	T	62.44	25864	120	SP	1,092.41	33174	141	T	83.30	36020	102	D	51.78	40090	126	T	30.62
25530	119	SP	123.11	25870	120	SP	1,814.64	35001	101	B	31.03	36021	102	D	54.75	40093	126	T	15.47
25540	56	SP	918.73	25872	120	SP	845.70	35002	101	B	32.15	36022	102	D	72.82	40095	126	T	65.87
25601	119	SP	48.15	25874	120	SP	978.21	35003	101	B	37.70	36031	102	W	45.45	40250	124	T	68.28
25602	119	SP	26.71	28840	57	D	138.55	35004	101	C	50.45	36032	102	W	54.48	40260	124	T	249.92
25603	119	SP	48.06	29503	129	T	29.62	35005	101	D	58.25	36040	102	W	36.30	40270	125	SP	28.08
25604	119	SP	26.71	29504	129	T	25.97	35006	101	W	76.97	36041	102	W	39.37	40310	125	T	54.67
25605	119	SP	26.71	29505	129	T	22.43	35007	101	W	77.97	36042	102	W	43.12	40340	125	X	23.72
25606	119	SP	26.71	32012	142	W	283.25	35010	101	C	15.52	36050	102	W	28.25	40702	139	T	10.62
25611	119	SP	26.71	32111	105	T	133.25	35011	101	C	16.58	36051	102	W	30.42	40706	139	T	27.05
25612	119	SP	26.71	32115	105	T	76.80	35012	101	C	18.48	36052	102	W	32.63	40710	139	T	43.20
25613	119	SP	48.15	32116	105	T	133.25	35015	101	W	78.67	36060	102	W	50.33	40900	125	T	29.03
25615	119	SP	32.05	32120	106	SP	69.15	35016	101	W	80.25	36061	102	W	53.03	40910	125	T	216.37
25620	57	SP	880.27	32121	106	SP	69.15	35017	101	W	82.07	36062	102	W	58.73	40915	125	SP	153.72
25701	119	SP	37.30	32122	106	SP	69.15	35020	101	W	15.92	36070	102	W	43.92	40920	125	T	204.47
25702	119	SP	39.25	32123	106	SP	69.15	35021	101	W	18.55	36071	102	W	28.15	40923	125	T	33.52
25710	118	SP	280.21	32124	106	SP	69.15	35022	101	W	18.07	36072	102	W	52.73	40925	125	T	33.52
25712	118	SP	74.91	32125	106	SP	69.15	35030	102	W	43.73	36080	104	W	65.15	40927	125	T	33.52
25713	118	SP	255.96	32126	106	SP	69.15	35031	102	W	44.92	36085	104	D	65.15	40929	125	T	132.38
25715	118	SP	314.70	32127	106	SP	69.15	35032	102	W	49.08	36087	104	C	46.93	40930	126	X	101.20
25730	120	SP	TBA	32128	106	SP	69.15	35040	102	A	42.40	36090	102	W	42.25	40940	126	T	1,249.97

† POPULARITY CODES = A, B, C, D, W, X - STANDARD POP CODES • T - TOOL • SP - SPECIAL ORDER
 PRICING EFFECTIVE 7/1/2013 • PRICING SUBJECT TO CHANGE • FOR CURRENT PRICING CALL 800-525-6505

NUMERICAL INDEX & RETAIL PRICING (U.S. DOLLARS)

Item	Page	Pop†	MSRP	Item	Page	Pop†	MSRP	Item	Page	Pop†	MSRP	Item	Page	Pop†	MSRP	Item	Page	Pop†	MSRP
41000	126	T	167.70	63020	59	D	177.55	67360	65	W	169.55	69330	128	T	26.57	71723	72	C	13.73
41030	126	T	69.08	63030	59	D	177.55	67370	65	W	169.55	69400	71	W	399.52	71724	72	C	13.73
41110	126	T	360.57	64225	127	T	196.72	67395	65	C	162.88	69450	71	W	320.52	71725	72	C	13.73
44339	125	SP	51.15	64250	108	SP	499.87	67410	66	A	169.85	69460	71	W	322.97	71730	72	A	13.73
45938	127	T	50.52	65100	127	T	435.23	67420	66	A	157.12	70050	130	SP	8.13	71731	72	A	13.73
45940	127	T	49.90	66025	128	T	82.82	67430	66	A	173.12	70210	139	T	60.57	71732	72	C	13.73
47142	58	W	14.18	66040	59	C	311.82	67440	66	W	181.78	70606	139	T	27.75	71733	72	C	13.73
47143	58	W	16.82	66045	59	C	311.82	67455	66	SP	237.08	71000	71	C	153.78	71909	128	T	196.28
47150	58	D	14.25	66050	60	SP	65.18	67465	67	C	153.82	71020	71	C	12.82	71959	128	T	37.77
47151	58	C	15.25	67010	60	W	113.00	67470	67	A	278.30	71021	71	C	12.82	71969	128	T	37.77
47152	58	A	17.37	67015	60	SP	117.85	67485	67	SP	153.75	71022	71	C	12.82	71979	128	T	37.77
47153	58	A	23.15	67018	60	C	153.67	67490	67	D	168.88	71023	71	C	12.82	71989	128	T	41.52
47171	58	W	32.73	67020	60	C	115.58	67510	67	SP	106.07	71024	71	C	12.82	71999	128	T	41.52
47172	58	W	32.73	67025	61	C	115.58	67515	67	SP	106.07	71025	71	C	12.82	72040	73	C	436.82
47173	58	W	35.67	67030	61	A	112.25	67520	68	SP	171.07	71031	72	SP	13.73	72045	73	SP	282.55
47180	58	W	13.42	67065	61	C	185.22	67525	68	D	157.73	71032	72	SP	13.73	72050	73	B	167.60
47181	58	D	15.07	67070	62	W	120.67	67530	68	D	157.73	71033	72	SP	13.73	72055	73	C	51.27
47182	58	C	18.48	67075	62	W	71.33	67540	68	SP	441.63	71034	72	SP	13.73	72060	73	SP	684.22
47183	58	C	26.30	67080	62	C	113.97	67545	68	SP	160.45	71035	72	SP	13.73	72065	74	SP	767.67
47184	58	W	27.55	67090	62	A	162.88	67550	68	SP	160.45	71041	72	SP	13.73	72070	74	SP	767.67
47240	59	W	29.97	67095	62	C	162.88	67555	68	SP	128.33	71042	72	SP	13.73	72080	74	SP	767.67
47241	59	W	31.88	67110	62	C	146.25	67570	69	SP	171.07	71045	72	SP	13.73	72090	74	SP	767.67
47242	59	W	34.18	67115	63	C	169.55	67580	69	A	153.60	71046	72	SP	13.73	72095	129	T	62.60
47700	58	SP	375.12	67125	63	A	157.73	67590	69	C	162.78	71051	72	SP	13.73	72110	74	SP	690.73
47762	58	W	19.25	67135	63	A	157.73	67610	69	W	680.67	71052	72	SP	13.73	72125	74	SP	913.27
47763	58	D	19.27	67145	63	A	157.73	67620	69	W	767.67	71053	72	SP	13.73	72130	75	SP	787.42
47764	58	W	21.52	67155	63	W	157.73	67630	69	SP	697.88	71054	72	SP	13.73	72180	75	SP	605.92
47765	58	W	14.00	67165	63	D	157.73	67640	69	C	288.63	71055	72	SP	13.73	72185	75	SP	169.55
47766	58	D	16.00	67170	63	D	157.73	67647	128	T	21.63	71061	72	SP	13.73	72190	75	SP	767.67
47767	58	D	18.48	67180	63	D	157.73	67655	70	SP	171.07	71062	72	SP	13.73	72260	76	B	171.60
47768	58	C	25.75	67190	63	C	157.73	67660	70	B	208.27	71065	72	SP	13.73	72265	76	B	48.82
47769	58	W	36.08	67195	63	D	157.73	67720	70	C	238.82	71066	72	SP	13.73	72270	76	SP	733.18
47775	58	D	16.40	67210	63	W	331.48	67740	70	C	122.25	71500	72	W	255.70	72280	76	SP	167.60
47776	58	D	21.33	67220	64	W	157.73	67765	70	C	277.85	71520	72	A	13.73	72290	76	W	167.60
47777	58	C	31.15	67230	64	A	153.67	67775	70	C	277.85	71521	72	A	13.73	72345	77	SP	355.82
47778	58	W	43.70	67245	64	W	37.73	67776	70	C	277.85	71522	72	C	13.73	72350	77	C	79.73
55600	127	T	152.80	67265	64	W	216.82	68670	128	T	58.82	71523	72	C	13.73	72355	77	SP	27.12
55605	127	T	52.58	67270	64	W	170.12	68750	128	T	42.58	71530	72	A	13.73	72509	129	T	301.25
55607	127	T	52.58	67285	64	W	183.27	68780	128	T	42.58	71531	72	A	13.73	73010	129	T	177.48
55609	127	T	52.58	67290	65	A	171.07	68880	128	T	79.28	71532	72	C	13.73	73119	129	T	137.82
55700	127	T	280.85	67300	65	SP	21.63	68890	128	T	87.30	71533	72	C	13.73	73400	77	D	44.60
55705	127	T	76.90	67320	65	W	169.55	69100	71	W	399.52	71700	72	SP	274.55	73415	77	W	19.25
55710	127	T	170.37	67330	65	W	169.55	69200	71	W	399.52	71720	72	A	13.73	73600	77	B	68.58
55720	127	T	38.10	67340	65	W	169.55	69250	71	W	265.63	71721	72	A	13.73	73620	77	B	86.60
62010	59	SP	256.30	67350	65	W	169.55	69300	71	W	399.52	71722	72	C	13.73	74400	129	T	42.92

† POPULARITY CODES = A, B, C, D, W, X - STANDARD POP CODES • T - TOOL • SP - SPECIAL ORDER
 PRICING EFFECTIVE 7/1/2013 • PRICING SUBJECT TO CHANGE • FOR CURRENT PRICING CALL 800-525-6505



www.specprod.com

Call for your nearest distributor, product info or
 Technical Assistance • In the USA and Canada

1-800-525-6505

Item	Page	Pop†	MSRP	Item	Page	Pop†	MSRP	Item	Page	Pop†	MSRP	Item	Page	Pop†	MSRP	Item	Page	Pop†	MSRP
74500	129	T	42.92	78090	131	T	156.77	83775	132	T	76.63	87365	87	SP	45.30	89799	90	W	183.78
74910	129	T	97.10	79230	131	T	14.28	83785	132	T	187.70	87385	87	A	81.03	89899	90	W	184.22
74914	129	T	34.63	79240	131	T	14.28	83788	109	T	21.23	87400	88	A	72.37	90203	139	T	33.97
74915	129	T	34.63	79500	131	T	188.05	83790	83	C	40.82	87420	88	A	24.12	90310	139	T	61.15
75200	78	A	15.82	80199	78	SP	84.33	83820	132	T	58.20	87430	88	SP	51.37	91000	136	T	183.55
75400	78	A	15.82	80206	139	T	30.67	83850	133	T	69.53	87500	88	A	79.48	91010	136	T	203.96
75500	130	T	179.05	80210	139	T	45.72	84238	109	W	12.63	87520	88	A	52.58	91025	121	T	327.29
75520	130	T	44.97	80299	78	SP	88.93	84690	83	D	20.52	87530	134	T	31.52	91030	136	T	52.26
75525	130	T	44.97	80399	78	SP	96.40	84695	83	D	20.52	87535	89	D	29.97	91040	109	T	798.95
75530	130	T	44.97	80499	78	SP	104.25	85125	133	T	174.05	87540	89	W	100.52	91045	136	T	15.30
75550	130	T	44.97	80599	78	SP	104.25	85126	133	T	34.58	87545	89	W	100.52	91088	137	T	316.08
75555	130	T	44.97	80699	78	SP	117.88	85127	133	T	48.82	87560	134	T	49.92	91100	136	T	61.75
75560	130	T	44.97	80799	78	SP	117.52	85128	133	T	92.82	87910	122	T	1,269.13	91800	109	T	3,570.13
75580	108	T	110.90	80899	78	SP	119.08	85130	133	T	88.25	88120	48	SP	29.97	91841	109	T	974.82
75585	108	T	110.90	80999	78	SP	127.40	85137	133	T	48.82	88210	47	SP	805.30	91844	110	T	125.58
75600	78	A	15.82	81099	78	SP	134.92	85560	3	SP	24.95	88260	47	SP	688.60	91851	138	T	621.25
75800	78	A	15.82	81133	132	T	16.80	85600	83	SP	72.78	88270	47	SP	962.92	91860	110	T	125.58
75910	78	T	13.13	81134	132	T	33.03	85690	84	W	21.38	88325	135	T	48.37	91877	110	T	257.10
75915	78	T	35.30	81139	132	T	130.70	85695	84	W	21.38	88360	135	T	51.15	91887	110	T	278.47
75920	78	T	3.00	81240	79	W	41.60	85774	133	T	12.70	88700	47	SP	348.48	91888	110	T	278.62
75970	78	C	37.78	81250	79	A	41.97	85790	133	T	49.25	88830	135	T	113.52	91889	110	T	421.20
75980	131	T	91.03	81260	79	A	41.97	85796	133	T	95.53	88901	89	X	155.08	91890	110	T	648.95
75990	131	T	91.03	81270	79	A	46.37	86140	84	B	155.73	88902	89	X	155.08	91891	110	T	338.20
76610	130	T	44.97	81280	79	A	46.37	86180	84	B	77.63	88903	89	X	105.22	91896	110	T	153.82
76615	130	T	44.97	81290	79	A	46.37	86250	84	A	64.12	88904	89	X	105.22	91988	110	T	685.42
76620	130	T	44.97	81305	80	A	41.97	86255	84	SP	28.08	88905	89	X	91.08	91990	110	T	1,057.10
76625	130	T	44.97	81309	108	T	121.38	86320	85	C	15.00	88906	89	X	91.08	92002	115	SP	46.66
76630	130	T	44.97	81310	80	A	50.33	86325	85	A	42.00	88915	89	A	258.30	92003	115	SP	46.66
76635	130	T	44.97	81320	80	B	118.70	86330	85	W	90.00	88920	89	A	283.30	92004	115	SP	36.71
76640	130	T	44.97	81340	80	C	191.55	86350	85	C	90.00	88940	90	W	149.03	92005	114	SP	15.41
76645	130	T	44.97	81350	80	W	449.97	86360	85	C	18.85	88950	90	W	293.45	92006	115	SP	36.71
76650	130	T	44.97	81360	80	W	449.97	86370	86	C	9.07	89000	135	T	125.33	92007	115	SP	53.69
76655	130	T	44.97	82110	81	C	33.88	86375	86	A	47.73	89105	135	T	37.48	92008	115	SP	53.69
76660	130	T	44.97	82120	81	C	41.88	86640	86	B	90.58	89106	135	T	37.97	92009	115	SP	53.69
76665	130	T	44.97	82360	81	SP	36.27	86680	86	B	67.12	89107	135	T	40.10	92010	114	SP	1.00
76670	130	T	44.97	82370	81	W	47.97	87130	134	T	60.20	89108	135	T	48.30	92011	114	SP	1.49
76700	130	T	178.08	82380	81	B	51.07	87135	134	T	74.53	89199	90	W	143.52	92013	114	SP	15.41
76760	130	T	44.97	82385	82	SP	51.07	87175	134	T	49.13	89299	90	C	151.42	92014	114	SP	0.61
76800	130	T	380.30	82390	81	C	51.07	87270	86	W	58.22	89399	90	C	157.45	92019	114	SP	1.00
76900	130	T	446.80	82395	82	D	60.15	87280	86	W	53.75	89499	90	C	166.25	92021	114	SP	72.30
77210	131	X	115.53	83115	82	D	130.73	87310	87	A	55.63	89599	90	D	172.85	92025	114	SP	18.71
77350	131	T	104.33	83125	108	T	91.47	87320	134	T	51.15	89635	90	D	192.48	92033	115	SP	58.25
77880	131	T	178.82	83160	82	D	42.08	87325	134	T	47.37	89675	90	W	115.55	92035	115	SP	58.25
77928	137	T	52.85	83170	82	B	46.93	87330	87	B	114.63	89685	90	W	270.88	92040	114	SP	12.24
77938	137	T	77.58	83710	83	D	40.82	87350	87	D	45.67	89699	90	D	175.00	92042	113	SP	161.16

† POPULARITY CODES = A, B, C, D, W, X - STANDARD POP CODES • T - TOOL • SP - SPECIAL ORDER
 PRICING EFFECTIVE 7/1/2013 • PRICING SUBJECT TO CHANGE • FOR CURRENT PRICING CALL 800-525-6505

NUMERICAL INDEX & RETAIL PRICING (U.S. DOLLARS)

Item	Page	Pop†	MSRP	Item	Page	Pop†	MSRP	Item	Page	Pop†	MSRP	Item	Page	MSRP	Item	Page	Pop†	MSRP	
92043	113	SP	161.16	93430	114	SP	74.91	94450	95	SP	249.91	SPC Gear/Publications							
92044	113	SP	161.16	93440	114	SP	74.91	94451	95	SP	249.91	20013	Pub.	5.00					
92045	114	SP	19.71	93450	114	SP	74.91	94460	95	SP	249.91	20106	106	14.95					
92046	113	SP	161.16	93460	114	SP	74.91	94461	95	SP	249.91	20107	143	14.95					
92050	114	SP	15.51	93470	114	SP	74.91	94800	91	SP	263.29	20108	143	4.95					
92052	113	SP	161.16	93480	114	SP	74.91	95332	95	SP	83.25	63000L	143	29.95					
92053	113	SP	161.16	94000	91	SP	250.75	95333	95	SP	95.20	63000M	143	29.95					
92054	113	SP	161.16	94002	91	SP	28.59	95336	95	SP	590.12	63000XL	143	29.95					
92055	114	SP	21.40	94003	91	SP	35.75	95338	95	SP	35.33	63000XXL	143	29.95					
92056	113	SP	161.16	94004	91	SP	31.86	95339	95	SP	16.79	63004	144	13.95					
92060	114	SP	18.71	94006	91	SP	26.79	97100	114	SP	26.25	63007	144	13.95					
92065	114	SP	23.54	94007	91	SP	29.91	97650	135	T	76.72	63010L	143	24.95					
92080	114	SP	18.71	94008	91	SP	28.59	99361	137	T	126.72	63010M	143	24.95					
92090	114	SP	18.71	94013	114	SP	15.21	99374	137	T	116.58	63010XL	143	24.95					
92142	113	SP	161.16	94014	114	SP	26.79	99511	138	T	544.33	63010XXL	143	24.95					
92242	113	SP	161.16	94016	91	SP	74.91	99512	138	T	568.95	64005L	144	14.95					
92244	113	SP	161.16	94017	91	SP	74.91	99515	111	T	623.10	64005M	144	14.95					
92252	113	SP	161.16	94018	91	SP	74.91	99516	138	T	134.47	64005XL	144	14.95					
92254	113	SP	161.16	94019	91	SP	74.91	99517	111	T	852.52	64005XXL	144	14.95					
92342	113	SP	161.16	94041	114	SP	108.25	99548	138	T	474.37	66010L	144	65.95					
92344	113	SP	161.16	94100	114	SP	105.61	99684	137	T	1,312.77	66010M	144	65.95					
92352	113	SP	161.16	94304	93	SP	42.95	99750	137	T	1,944.28	66010XL	144	65.95					
92354	113	SP	161.16	94305	92	SP	279.45	99801	111	T	554.52	66020L	144	24.95					
92542	113	SP	161.16	94306	93	SP	42.95	99884	138	T	595.15	66020M	144	24.95					
92546	113	SP	161.16	94320	92	SP	250.75	99886	138	T	873.97	66020S	144	24.95					
92552	113	SP	161.16	94330	92	SP	279.45	99918	137	T	117.87	66020XL	144	24.95					
92556	113	SP	161.16	94331	92	SP	279.45	99961	137	T	40.77	66065L	144	14.95					
92646	113	SP	161.16	94332	92	SP	279.45	204508	129	T	71.67	66065M	144	14.95					
92656	113	SP	161.16	94340	92	SP	263.29	305227	129	T	51.72	66065XL	144	14.95					
92740	93	SP	193.45	94344	93	SP	590.12	305228	129	T	67.43	66065XXL	144	14.95					
92748	93	SP	214.95	94346	95	SP	83.25	857901	133	T	16.57	66070L	144	65.95					
92749	93	SP	214.95	94348	95	SP	35.33	WA5119	138	SP	20.60	66070M	144	65.95					
92750	93	SP	214.95	94350	93	SP	263.29	WA515-9L	138	SP	25.78	66070XL	144	65.95					
92751	93	SP	214.95	94360	93	SP	263.31					66070XXL	144	65.95					
93000	91	SP	236.41	94368	93	SP	263.31					67001	145	2.99					
93010	91	SP	236.41	94369	93	SP	263.31					67002	145	0.99					
93020	91	SP	171.91	94370	93	SP	263.31					67003	145	12.95					
93030	91	SP	171.91	94371	93	SP	263.31					67008	145	0.99					
93040	91	SP	287.90	94374	94	SP	590.12					82013	Pub.	15.63					
93050	91	SP	287.90	94378	94	SP	TBA					88033	145	11.17					
93080	91	SP	171.91	94390	94	SP	396.69					88035	145	30.00					
93090	91	SP	171.91	94391	94	SP	396.69					88036	145	16.76					
93400	114	SP	74.91	94392	94	SP	396.69												
93410	114	SP	74.91	94393	94	SP	214.91												
93420	114	SP	74.91	94394	94	SP	214.91												

† POPULARITY CODES = A, B, C, D, W, X - STANDARD POP CODES • T - TOOL • SP - SPECIAL ORDER
 PRICING EFFECTIVE 7/1/2013 • PRICING SUBJECT TO CHANGE • FOR CURRENT PRICING CALL 800-525-6505



www.specprod.com

Call for your nearest distributor, product info or
 Technical Assistance • In the USA and Canada

1-800-525-6505

ALPHABETICAL INDEX

Adjustable Sleeves55	Dodge Camber Tool123	GM Alignment Tool132	Lexus GS/IS Rear Camber Kit67	Sockets - Deep, Thin Wall131
Adjustable Sleeves - Wrench129	Dodge Dana 60 Axle Cam/Cas Kit90	GM Bump Stop95	Lexus LX450 Front Bearings89	Spanner Wrench123
Adjusting Sleeves - Upper Control Arm114	Dodge Durango Front Cam/Cas Kit81	GM Bushing Press Adapters131	LH Replacement Sleeve53	Spherical Bearings117
Alignment Gauge - Magnetic137	Dodge Front Cas/Pinion Cams82	GM Camber Kit81	Light Truck/SUV Board47	Spindle Puller - 3-in-1133
Alignment Gauge Adapter137	Dodge H/D Pin Joint Adj Tool135	GM Camber/Caster Tool132	Lincoln LS Front Cam/Cas Kit89	Sprinter Van Front Adjuster Kit57
Aluminum Alloy Truck Axle Shim103	Dodge LH Toe Tool127	GM Colorado/Canyon Align Socket127	Lincoln Mark VIII Front Cam Kit89	Steering Boot - Uni-Fit142
Angle Gauge108	Dodge Mini-Van Front Camber Kit82	GM Full Size Truck/SUV/Van Cam/Cas83	Lo Profile Extender Bars110	Steering Knuckle Tool124
ASE Test Prep. Book3	Dodge Mini-Van Rear Shims72	GM HD Adj Ball Joint54	Lug Nut Cover Tool - Chrome109	Steering Wheels137
Audi Front Cam/Cas Kit80	Dodge Pin Joints53,54	GM Inner Tie Rod Crimper131	M10 X 1.5 X 40 Bolts49	Sterling Pin Joint Adjusting Tool135
Audi Front Upper MultiLink Arms80	Dodge Ram Caster Cams82	GM Mid-Sized Cam/Cas Cams85	Manganese Bronze HD Truck Axle Shim103	Sterling Pin Joints54
Audi Rear Shims72	Dodge Sleeve Puller135	GM Muscle Car 'A' Lower Arms93	Mazda3 Rear Camber Arm66	Stickers - SPC145
Axle Caliper - Tandem110,111	Dodge Truck Sleeve Puller131	GM Muscle Car 'A' Upper Arms92	Mercedes Bushing Press Adapters131	Subaru Adj Rear Arm70
Ball Cap - SPC144	Dodge/Jeep Pin Joints53	GM Muscle Car 'F' Lower Arms94	Mercedes Rear Bushings57	Subaru Adj Rear Toe Arm70
Ball Joint Plates - Racing115	Escort Toe Arms62	GM Muscle Car 'F' Upper Arms92	Mercedes Wheel Spreader137	Subaru/Saab EZ Arm XR™69
Ball Joint Press129	Extended Length Ball Joints91	GM Muscle Car 'G' Lower Arms95	Mercury Cougar Front Cam Kit89	T-Shirts - SPC144
Ball Joint Press - Performance125	EZ Cam™ XR79	GM Muscle Car 'G' Upper Arms92	Mini Cooper Adj Strut Tool129	Tandem Alignment Shim Set101
Ball Joint Press Adapter Set126	EZ Shim™ Board Set47	GM Muscle Car Ball joints91	Mini Cooper Front Strut Mount69	Tandem Alignment Systems111
Ball Joint Separator124,125	EZ Shim™ Cutter78	GM Muscle Car Spacer Kits93,95	Mini Cooper Rear Camber Arm69	Tandem Truck Single Slot Shim102
Ball Joints91	EZ Shim™ Dial Chart78	GM OE Cam/Cas Kit82	Mis-Alignment Inserts117	Tie Rod (Inner) Wrench Set135
Banners - SPC145	EZ Shim™ Dual Angle Shim78	GM Rear Toe Tool133	Mitsubishi Adj Ball Joint63,65	Tie Rod Adj Tool - Universal125
Bearing Receivers - Spherical117	EZ Shim™ Marker78	GM Strut Set126	Mitsubishi Lancer/Outlander Rear Arm66	Tie Rod Puller123
BMW 5/6 Series Adj Rear Bushings75	EZ Shim™ Spacer Set78	GM Theta Rear Cam Nut88	Mitsubishi Rear Camber Bracket77	Tie Rod Separator124,125
BMW Adj Damping Strut Tool129	FasTrax - Cam/Cas Gauge136	GM Truck/SUV Cam Lock Plate85	Mitsubishi Rear Shim Pack77	Tie Rod Tool123,126
BMW Front Strut Mounts74,75	FasTrax - Heavy Duty109	GM Truck/SUV Align Pins85	Mopar 'A', 'B', 'E' Adj Upper Arms95	Tie Rod Tool Kits128
BMW Rear Camber Arm62,74	FasTrax - Off Road121	GM Truck/SUV Front Cam Bushings85	Multi-Alignment Washers116	Tire Matting Square110
Brake Disc Grinding Pads141	FasTrax Toe Adapter136	GM Truck/SUV Repl. Front Plate and Cam86	Mustang Adj Panhard Bar73	Toe Bar Scribe138
Brake Drum Spacers107	Files - Rotary133	GM Truck/Van Cam Adj Tool127	Mustang Front Strut Mount73	Toe Bar Set - ATVs138
Brake Lathe Inserts (Bits)139	Flange Type Axle Puller122	GM Twist Beam Axle Rear Shims72	Mustang II Front Suspensions91	Toe Bar Set - Buses, Vans, RVs138
Brake Lathe Knob141	Flex Joint - Sealed - xAxis™116	GM Van Align Cam Plate86	Navistar Torque Arm Shim102	Toe Bar Set - Cars, Light Trucks138
Brake Lathe Rotor Silencers140	Ford 4WD/RWD Cam/Cas Sleeves52	GM Van/SUV RWD/4WD Cam/Cas Kit88	Navistar/Corporate Shim102	Toe Bar Set - Heavy Duty, OTR111
Brake Lathe Tool Holders140	Ford Adjustable Ball Joint63	GMC 10 Bolt 4WD Sleeves50	Neon EZ Arm XR™63	Toe Bar Set - Light Truck111
Brake Pedal Depressor137	Ford Aerostar Cam/Cas Wrench134	GMC Envoy/Jimmy Camber Kit83	Nissan Truck/SUV Cam/Cas Shims57	Toe Measuring Gauges137
Budd Nut Removal Tool108	Ford Contour Front Strut Munt90	GMC Van/Truck Cam/Cas Wrench134	Nissan 240SX Caster Rod70	Torque Extensions - Heavy Duty108
Bushing Press Set126	Ford Crown Vic Cam/Cas Wrench135	Golf Shirt - SPC143	Nissan 240SX Rear Camber Kits70	Torque Sticks130
Bushing Service Set - Upper Control Arm125	Ford Crown Vic Front Camber Bolt87	Hendrickson HD Shims104	Nissan 240SX Toe Link70	Toyota Avalon/Camry Camber Kit81
Camber Gauge - Magnetic, Adj132	Ford Dana 28 Twin Traction Sleeve51	Hendrickson Walking Beam Shim104	Nissan 350Z Adj Front Arms74	Toyota Caster Spacers84
Camber/ Caster Shims58	Ford Dana 44 Twin Traction Sleeve50	Honda Accord Rear Adj 3 Arm Set68	Nissan 370Z Adj Front Arms75	Toyota Celica Rear Camber Arm66
Camber/Caster Duo-Fit Shims58	Ford Dana 60 Axle Cam/Cas Kit90	Honda Adj Front Control Arm59	Nissan Altima Adj Rear Arm76	Toyota Landcruiser 80 Front Bearings89
Centering Sleeves-Steer & Drive107	Ford Escape Rear Camber Arm64	Honda Adjustable Ball Joint63,65	Nissan EZ Arm XR™60	Toyota Monobeam Cam/Cas Sleeves89
Centering Sleeves-Wheel & Brake Drum106	Ford Expedition Cam/Cas Kit86	Honda Bushing Extractor127	Nissan Leaf Rear Shims71	Toyota Sienna Rear Shims71
Centering Tool Set105	Ford Expedition Rear Kit86	Honda Bushing Press Adapters131	Nissan Rear Camber/Toe Kit73,76	Toyota Truck/SUV Adj Front Arms56
Chevy Blazer Camber Kit83	Ford Explorer Cam/Cas Kit87	Honda Civic Camber Bracket67	Nissan Sentra Rear Shims72	Toyota Truck/SUV Cam Bolt56
Chevy Camaro Adj Rear Cam88	Ford Explorer Cam/Cas Kit88	Honda Civic Rear Camber Arm67	Nissan Truck/SUV Adj Front Arms56	Toyota Truck/SUV Cam Extractor125
Chevy Corvette Adj Upper Arms93	Ford Explorer Front Cam/Cas Kit84	Honda Civic Rear Camber Arm67	Nissan Truck/SUV Cam/Cas Kit88	Tracker Set - Tandem Aluminum Wheels110
Chevy Dana 60 Axle Cam/Cas Kit90	Ford F-Series Coil Spring Bolt96	Honda Clearance Arm Socket128	Passenger Car Assortment Board47	Tri-5 Adj Upper Arms93
Chevy Impala Ad Upper Arms93	Ford F150 Adj Cam Nut/Bracket84	Honda Replacement Ball Joint62,64	Patch - SPC Sew On144	Truck Axle Caster Shims78
Chevy Truck/SUV Adj Front Arms57	Ford F150 Pinion Angle Shims84	Honda Ridgeline EZ Arm XR™67	Peterbilt Air Leaf Pinion Shim101	Truck Axle Shim103
Chevy Van/Truck Cam/Cas Wrench134	Ford F150/F250 (L/D) Cam/Cas Kit87	Honda S2000 Ball Joint64	Peterbilt Air Leaf Thrust Shim101	Truck Sleeve Board47
Chevy 1-1/2 & 2 Ton Sleeves52	Ford F250, F350 Sleeves52	Honda/Acura Caster Spacers83	Peterbilt Flex Air Shim102	Truck Sleeve Socket134
Chrysler Bushing Press Sleeves128	Ford Fixed Change SD Sleeves52	Honda/Acura Rear Clearance Arms71	Peterbilt Thrust Angle Shim102	Tubular Chassis Components117
Chrysler JC/JS EZ Arm XR™61	Ford Focus Front Cam/Cas Kit80	Honda/Acura Rear EZ Arm XR™61,62,64,65,69	Pin Wrench Set118	Turntables137
Chrysler LH Toe Tool127	Ford Focus Rear Camber Arm66	Honda/Acura Rear Toe Adjuster71	Pitman Arm Puller129	Turntables - Heavy Duty109
Chrysler Mini-Van Front Camber Kit82	Ford Focus Rear Camber Kit80	Honda/Acura Toe Adjusting Tool134	Pitman Arm Separator122	U' Bolt Extensions111
Chrysler Mini-Van Rear Shims72	Ford Mod Strut Camber Kit81	Hose Cutter123	Pitman Arm Tool125	Uni-Wedge Rear Axle Shims90
Chrysler OE Cam/Cas Kit82	Ford Mustang Front Alignment Kit77	Hyundai/Kia Rear EZ Arm XR™66	Plymouth 'A', 'B', 'E' Adj Upper Arms95	Upper Control Arms - Components114
Chrysler Rear Camber Bracket77	Ford Mustang II Front Suspension91	Hyundai/Kia Adj Ball Joint63	Point of Sale Poster143	Upper Control Arms - Racing112
Chrysler Rear Shim Pack77	Ford Mustang Rear Trailing Arms77	IHC Torque Arm Shim102	Prevost Caster Shim102	Valve Extension118
Chrysler Screw-In Ball Joint Socket128	Ford OE Cam/Cas Kit82	Infiniti G35 Adj Front Arms74	Prevost X & XL Shim102	Valve Stem Puller125
Chrysler Screw-In Ball Joints91	Ford Rotor-Bor133	Infiniti G37 Adj Front Arms75	Pro Springs94	Vanhool Bogey Axle Shim102
Chrysler SLA Cam/Cas Tool123	Ford RWD Camber Sleeve51	Infiniti Rear Camber/Toe Kit73,76	Punch - 1-1/8"129	Vanhool Drive Axle Shim102
Chrysler/Dodge Adj Ball Joint63,65	Ford SD Tie Rod Sleeve Adjuster131	Jacket - SPC144	Punch - Knock Out Align Insert129	Volvo Rear Camber Arm66
Chrysler/Dodge Adj Front Arm59	Ford SLA Cam/Cas Tool123	Jeep Adj. Ball Joint53	Racing Adj Upper Control Arms112	Volvo/White Tandem Shim102
Chrysler/Dodge EZ Arm XR™60,61,62	Ford Sleeve Puller135	Jeep Bushing Press Sleeves123	Radial Run-Out Gauge108,141	VW Front Cam/Cas Kit80
Chrysler/Dodge Rear Camber Kit60	Ford Super Duty Tie Rod Tools128	Jeep Caster Shims59	Radial Run-Out Gauge - Repl Gauge141	VW Front Upper MultiLink Arms80
Coil Spring Compressor - Internal124	Ford SUV Cam Adjusting Wrench132	Jeep Compass/Patriot Rear Arm66	Rim Guard - No Mar109	VW Mini-Van Front Camber Kit82
Coil Spring Compressor - Universal124	Ford T-Bird Front Cam Kit89	Jeep Front Cas/Pinion Angle Cams81	Rod End Receivers117	VW Rear Shims72
Coil Spring Spacers96	Ford T-Bird Front Cam/Cas Kit89	Jeep Grand Cherokee Cam/Cas Kit81	Rotary Files133	VW Shim Wrench134
Coil Spring Stabilizers96	Ford Taurus Front Camber Plates90	Jeep Pinion Shims78	Rotor Silencers140	Wheel Centering Tool Set105
Coil Spring Stabilizers96	Ford Taurus Rear Bushing Adj Tool134	Jeep Rear Pinion Angle Cams81	S-Cam Bushing Extractor110	Wheel Lock Removal Set126
Coool Tool Fluid133	Ford Taurus Rear Toe Wrench134	Jounce Spacers65	Saab/Subaru EZ Arm XR™69	Wheel Rim Straightening Tool - Steel108
Corvette Toe Shims58	Ford Taurus Sedan Cam/Toe Kit87	JounceShock Rebuild Kits118	Saturn Rear EZ Arm XR™64	Wheel Spreader137
Counter Mats143	Ford Taurus Wagon Rear Cam Kit87	JounceShock Systems120	Saturn Rear Toe Kit83	Wheel Stands - Front138
Cross Shafts114	Ford Taurus Wagon Rear Toe Tool135	JounceShock Upper/Lower Mounts119	Scion Adj Rear Arm70	Wheel Stands - Rear138
Custom Board Set48	Ford Truck Sleeve Puller131	JounceShocks™118	Scion Adj Rear Toe Arm70	Wheel Weight Tool124
CV Boot Clamp Install Tool142	Ford Truck/Van RWD Caster Kit86	Kenworth Air Glide Spacers101	Scion tC Rear Camber Arm67	Wheel Weight Tool - Truck108
CV Boot Clamps142	Ford Twin I-Beam Radius Arm Kensioners86	Kenworth Flex Air Shim102	Scion Toe Press Adapter128	Wilson/Hutchins Tandem Shim102
CV Joint Fork124	Ford Windstar Front Camber Plates90	Kenworth Thrust Angle Shim102	Shim Set - Duo Fit58	Wrench - Adjustable Sleeves129
CV Replacement Boots142	Ford 1-1/2 & 2 Ton Sleeves52	Kingpin Extensions110	Shim Set - SLA58	xAxis™116
Dana 44 4WD Sleeves50	Ford HD 4WD/RWD Sleeves51	Knock Out Punch129	Slide Hammers/Pullers122	Z-Block Truck Axle Shim Spacer Plate103
Dodge 'A', 'B', 'E' Adj Upper Arms95	Freightliner Adj Shims101	Leaf Spring Silencer™49	Slip Plates138	Zinc Alloy Truck Axle Shim103
Dodge 1500 Adj Ball Joint54	Freightliner Air Glide Shim102	Lexus ES250, 300 Camber Kit81	Slip Plates - Heavy Duty109,111	
Dodge 4WD/RWD Cam/Cas Kits53	Freightliner Fas II Shim102	Lexus GS Adj Front Arms76		
Dodge Bushing Press Sleeves123	Front Hub & Axle Puller122	Lexus GS/IS Adj Ball Joint68		
Dodge Caliper Rear Camber Arm66	Gloves - SPC144	Lexus GS/IS Rear Camber Arm68		

Training is your Future

We have various training options available to technicians including our popular in-house training classes (*see page 3 for more info*):

Basic Alignment

This four day Basic course which consists of presentations and demonstrations along with hands-on instruction is designed for Technicians with less than one year of hands-on alignment experience.

Local Field Clinics

Our three hour Field Clinics will provide you with reliable information to enable you to diagnose and align any vehicle correctly the first time. SPC's professional trainers provide specific alignment and suspension information on newer as well as problematic vehicles.

Advanced Alignment

This four day Advanced course which consists of presentations and demonstrations along with hands-on instruction is designed for Technicians working in the trade for a period of at least two years.

Online

If you want to stay competitive in today's high-tech automotive aftermarket Specialty Products Company now has both Basic and Advanced courses available online at www.specprod.com. These training courses were developed by ASE Master Certified technicians.



Look for the SPC-TV logo next to the parts in our catalog that feature video on how to install that part.

Tune In • Log On • Earn Now

SPC-TV is the best way to get all the latest info from Specialty Products. Watch videos that show you how to install our parts, and then participate in our interactive rewards program.

- Log on to www.spc-tv.com and register - it's easy!
- Watch short videos that show how to install popular parts and our favorite tools
- Learn how to do your job better and faster
- Earn points and get great gear from SPC

Save Your Box Tops - Earn Great Stuff



For each box top you send in you can earn great SPC Gear or VISA® Debit Cards. You can also earn entries into our quarterly contests where you can win a \$250 VISA® Debit Card or our Grand Prize - *a trip for 2 to the SEMA show in Las Vegas*. Call customer service at 800-525-6505 for more info!

For Professionals - By Professionals



Pioneering the alignment parts business in 1971, Specialty Products has lead the industry for over 40 years. Preferred by professional installers for its innovation, quality, and service Specialty Products is the industry's first choice in alignment parts and tools.

SPC Performance parts and tools have been engineered to assist installers that need to correct suspension angles on racing, street rod, muscle car, off road, sport and sport compact vehicles. These parts give suspensions a true advantage with optimal tracking and handling in professional chassis set ups.

800-525-6505 • www.specprod.com

All products from Specialty Products Company are intended for use by professional installers only.



**Specialty
Products
Company.**

**SPC
PERFORMANCE.**

In the USA & Canada:

**SHIPPING ADDRESS:
4045 Specialty Place
Longmont, CO 80504 USA**

**MAILING ADDRESS:
P.O. Box 923
Longmont, CO
80502 USA**

**TELEPHONE:
303-772-2103
FAX: 303-772-1918**

**Proven Quality
Complete Line
Preferred Brand
Unsurpassed Service
Field Sales Support
New Product Development
Technical Training & Support**



**SPC-TV is the
best way to get
all the latest info
from Specialty
Products. Look for
this logo as your
direct link from**

**catalog to video. Just scan the QR
Code with your smart phone, iPad® or
tablet and watch great videos that
show you how to install our parts.
Plus you can participate in an
interactive rewards program. See the
inside back cover for more - or go to**

www.spc-tv.com

MEMBERSHIPS



**An ISO/TS 16949 Company
Distributed By**

**TOLL FREE
800-525-6505
www.specprod.com**

**No. 20013
Supersedes No.
20012
Printed in USA**

