

ITEM NO.	QTY.	PART NUMBER	DESCRIPTION
1	1	67545124	RH WELDMENT
2	1	6754513	LH END
3	1	670101-10	JAM NUT, RH M18-1.5
4	1	670101-11	JAM NUT, LH M18-1.5
5	1	60007202	ADJUSTER
6	1	67235	HFLN, M12-1.25

PART NUMBER IP-349		REAR LOWER ARM ASSEMBLY			
DATE	REV	REVISION HISTORY		DWG	ECN
05/21/09	B	INITIAL RELEASE OF IP		JSP	856

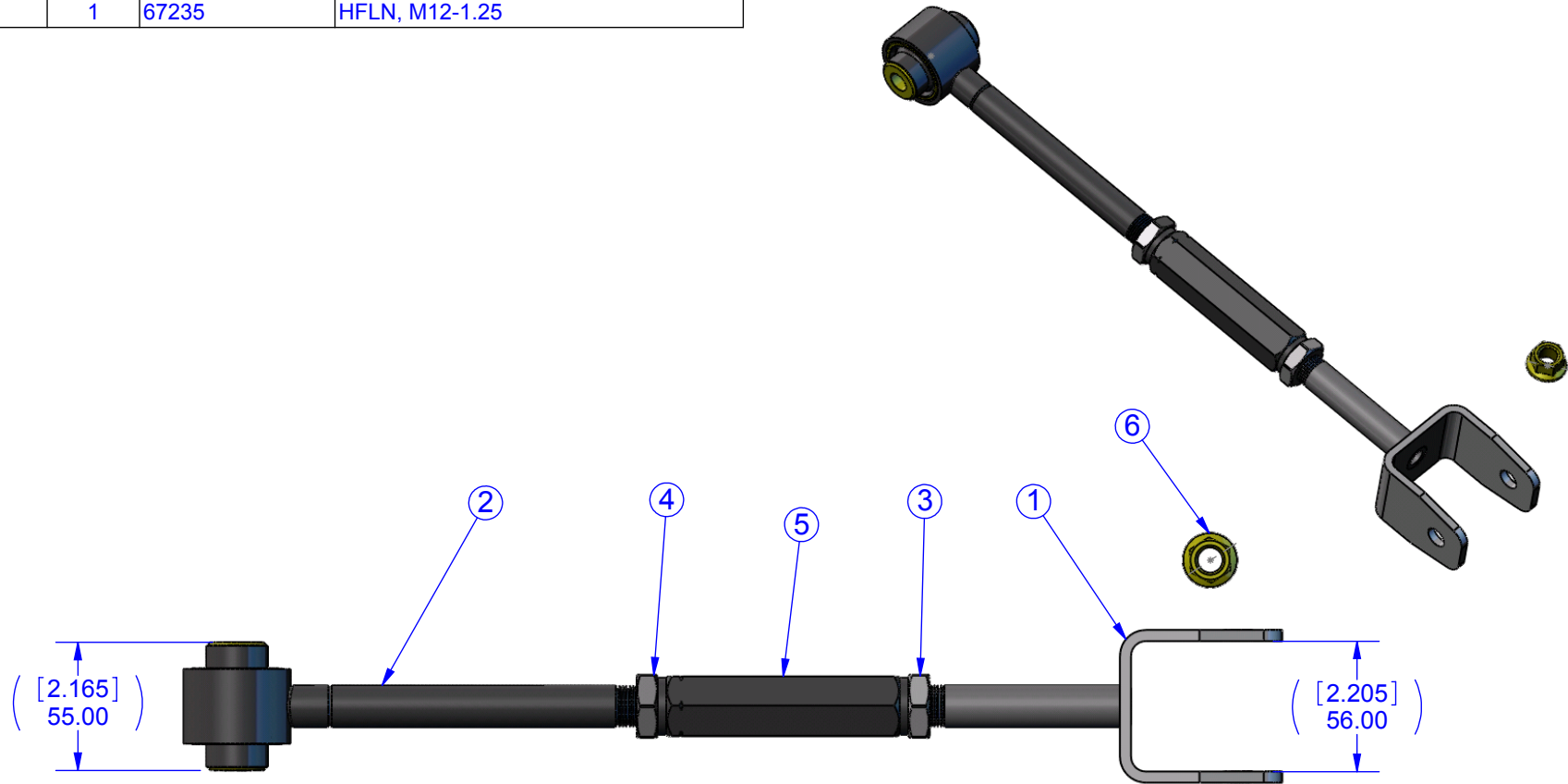

## INSPECTION PRINT FOR 675451

THIS DOCUMENT CONTAINS PROPRIETARY INFORMATION WHICH SHALL NOT BE REPRODUCED, TRANSFERRED TO OTHER DOCUMENTS, DISCLOSED TO OTHERS, USED FOR MANUFACTURING OR ANY OTHER PURPOSE WITHOUT PRIOR WRITTEN PERMISSION FROM SPECIALTY PRODUCTS COMPANY.

UNDIMENSIONED FEATURES ARE  $\pm 0.5\text{MM}$  UNLESS OTHERWISE SPECIFIED DIMENSIONS AND TOLERANCES ARE IN MILLIMETERS AND DECIMAL DEGREES: X  $\pm 1.5$ , X.X  $\pm 0.70$ , X.XX  $\pm 0.25$ , ANGLES  $\pm 2.0^\circ$  CONFORMS TO ASME Y14.5M-1994



**Specialty Products Company™**  
Longmont, CO 80504

**IP-349 REAR LOWER ARM ASSEMBLY**

SCALE 1:3	DO NOT SCALE DRAWING	CONTRACT	CHECKED CCH	DRAWN DHH	SIZE A	DATE 06/30/08	REV B	SHEET 1 OF 11
-----------	----------------------	----------	-------------	-----------	--------	---------------	-------	---------------