

ITEM	QTY	PART NO.	DESCRIPTION
1	1	7352	Sleeve, Adjustable - Inner half
2	1	7353	Sleeve, Adjustable - Outer half

7351 Assembly, Truck Sleeve - Adjustable				
DATE	REV	REVISION COMMENTS	BY	ECN
	--		---	0
08/26/03	A	NHA 24120 was 735	---	0
25 May 11	B	Updated Sht. Blk; Part converted from 2D to 3D; Notes removed; views altered and iso-view added; some tol changes.	RAH	1080

NOTES:
 1. Press item 1 into item 2 with slots aligned +/- 2° and until fully engaged with protrusion dimension shown.

This drawing may be used for Receiving Inspection

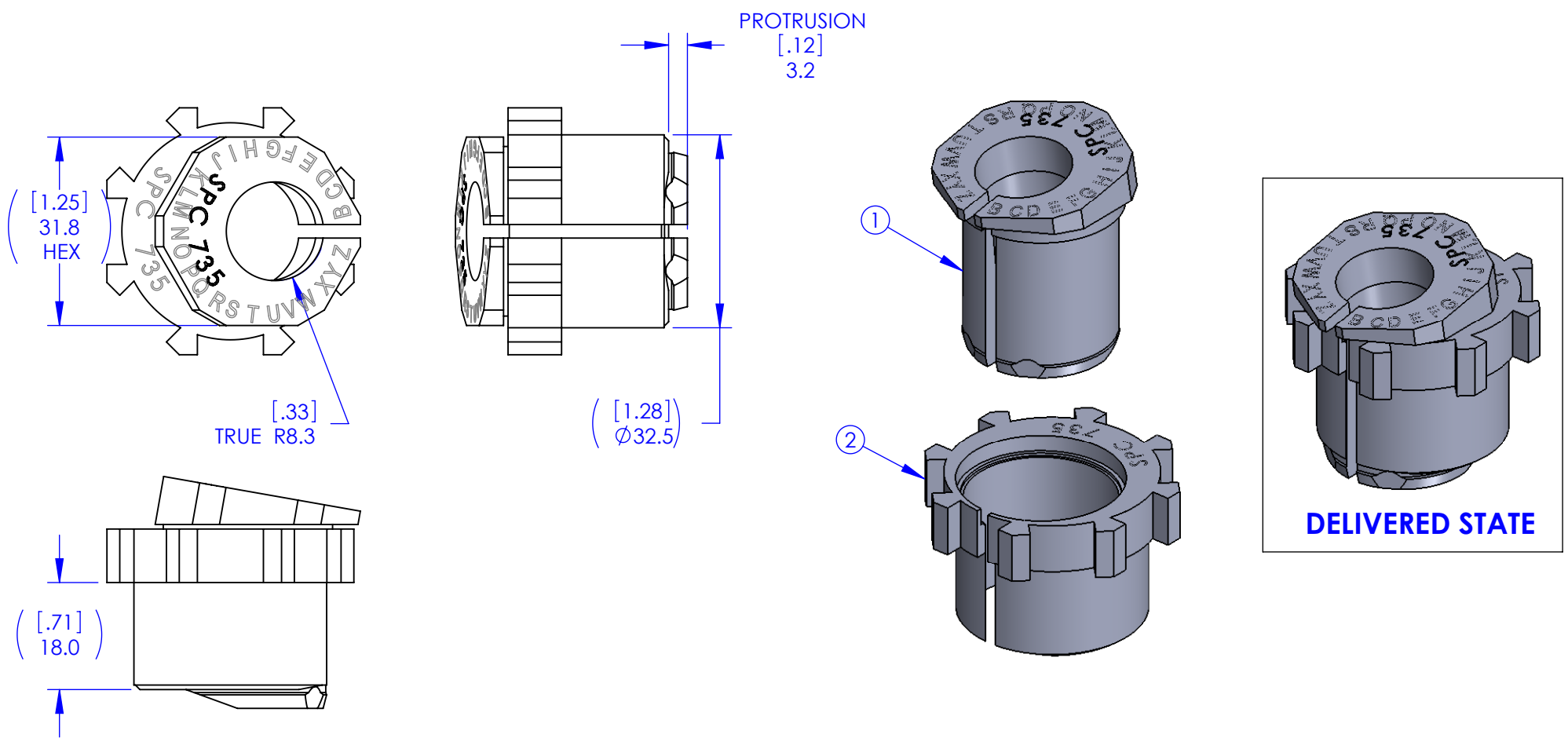

INTERPRET & PROCESS
per MSS-4.000



Specialty Products Company
 Longmont, Colorado USA • www.specprod.com

7351 Assembly, Truck Sleeve - Adjustable

PROPRIETARY AND CONFIDENTIAL THIS DOCUMENT CONTAINS PROPRIETARY INFORMATION WHICH SHALL NOT BE REPRODUCED, TRANSFERRED TO OTHER DOCUMENTS, DISCLOSED TO OTHERS, USED FOR MANUFACTURING, OR ANY OTHER PURPOSE WITHOUT PRIOR WRITTEN PERMISSION FROM SPECIALTY PRODUCTS COMPANY	DO NOT SCALE DRAWING UNDIMENSIONED FEATURES ARE CONSIDERED NOMINAL AT 3D MODEL SURFACES WITH TOLERANCE ±0.50mm[0.020"]	CONFORMS TO ASME Y 14.5M 1994 LINEAR mm[in] ANGLE (deg.) None±1.00 [X ±.040"] None± 2.0° X ±0.50 [XX ±.020"] X ± 1.0° .XX ±0.25 [.XXX±.010"] .XX ± 0.5°	DRAWN: RAH	MATERIAL: See Components	Rev. B
		DATE: 02/02/11	FINISH: See Components	SHEET 1 of 1	
		CHECKED: ---			