

[2.00]
Ø50.8

Part Number
Stamping

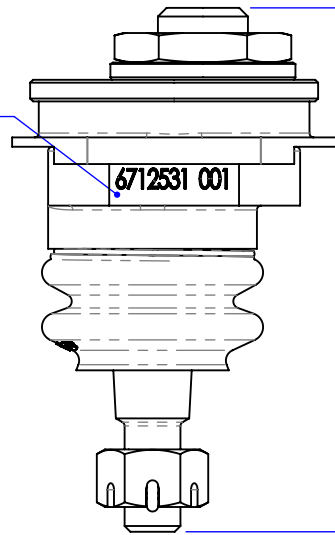

[3.6]
92

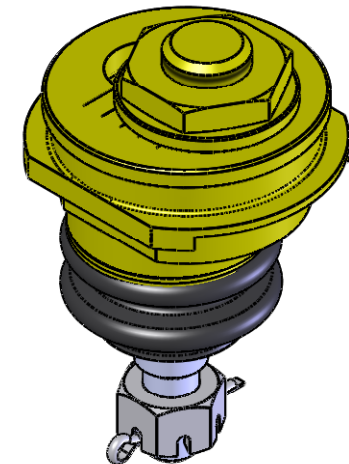

Specialty Products Company
Longmont, Colorado USA • www.specprod.com

671253 Kit, Offset Ball Joint w/ Hardware

PROPRIETARY AND CONFIDENTIAL
This document contains proprietary information which shall not be reproduced, transferred to other documents, disclosed to others, used for manufacturing, or any other purpose without prior written permission from Specialty Products Company.

DO NOT SCALE DRAWING
UNDIMENSIONED FEATURES ARE CONSIDERED NOMINAL AT 3D MODEL SURFACES WITH TOLERANCE ±0.50mm[0.020"]

CONFORMS TO ASME Y14.5
LINEAR mm[in] ANGLE (deg.)
None±1.00 [.X ±.040"] None±2.0°
.X ±0.50 [.XX ±.020"] .X ±1.0°
.XX ±0.25 [.XXX±.010"] .XX ±0.5°

Drawn: RDS
Date: 03/03/06
EngCode: BAJT - A

MATERIAL: See Components
FINISH: See Components

Rev. **C**
SHEET 2 of 2