

NOTES:

1. THIS DRAWING IS INTENDED FOR INSPECTION PURPOSES ONLY AND NOT FOR ENGINEERING/PRODUCTION PURPOSES.
2. PACKAGED WITH INSTRUCTION SHEET.
3. ALL COMPONENTS HAVE A BLACK FINISH.
4. THE MINIMUM THREAD ENGAGEMENT ALLOWED BETWEEN THE ITEMS #1 AND #2 ASSEMBLIES AND THE ITEM #3 ADJUSTER IS 0.75 INCHES.
5. MAXIMUM WORKING EXTENDED LENGTH TO BE APPROXIMATELY 8.0 INCHES.

IP 045

INSPECTION PRINT

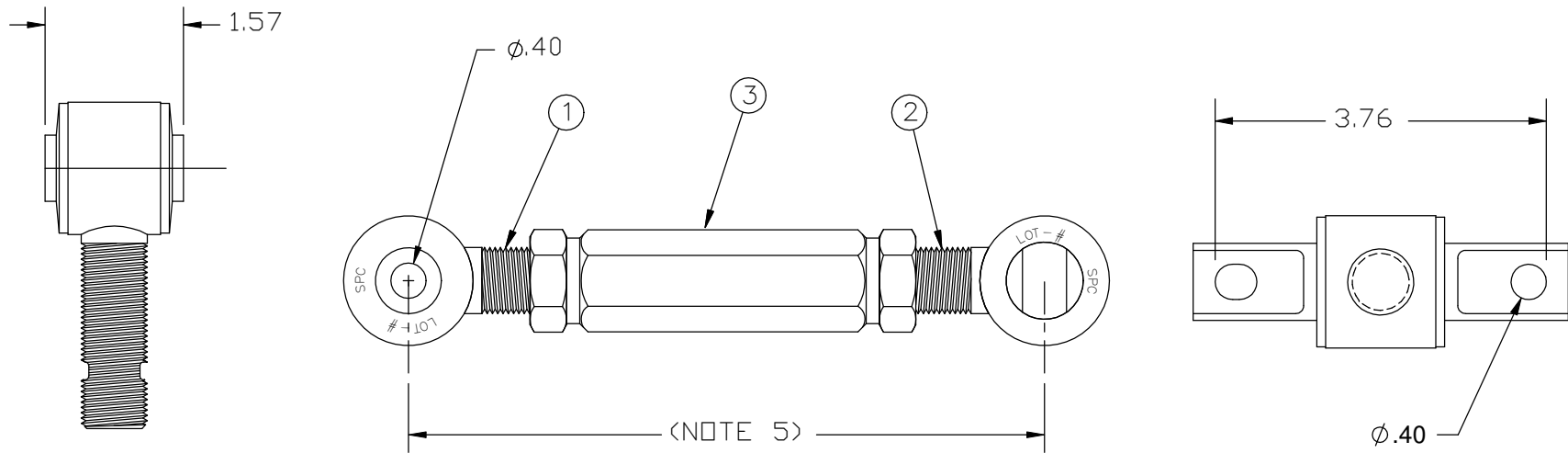

DO NOT SCALE DRAWING

KIT P/N 67030

SPECIALTY PRODUCTS COMPANY

COMPANY CONFIDENTIAL PROPRIETARY INFORMATION;
REPRODUCTION OR UNAUTHORIZED USE PROHIBITED

10.5"x8.0"

IP 045

ADJ. CONTROL ARM

SHEET 1 OF 1

REV. -

DRAWN BY: WDS

SCALE: 1:2

APPROVED BY:

DATE: 12/30/99

NOTES:

DIMENSIONS & TOLERANCES IN INCH & DECIMAL DEGREE
UNSPECIFIED TOLERANCES: X.X±10 ,X.XX ±03 ,X.XXX ±01 ,ANGLES .5°
CONFORMS TO SS-100, UNLESS OTHERWISE SPECIFIED