

PART NO.	DEG. CHANGE	("A")
231911	2.75°	.406
231921	3.00°	.381
231931	3.25°	.356
231941	3.50°	.324

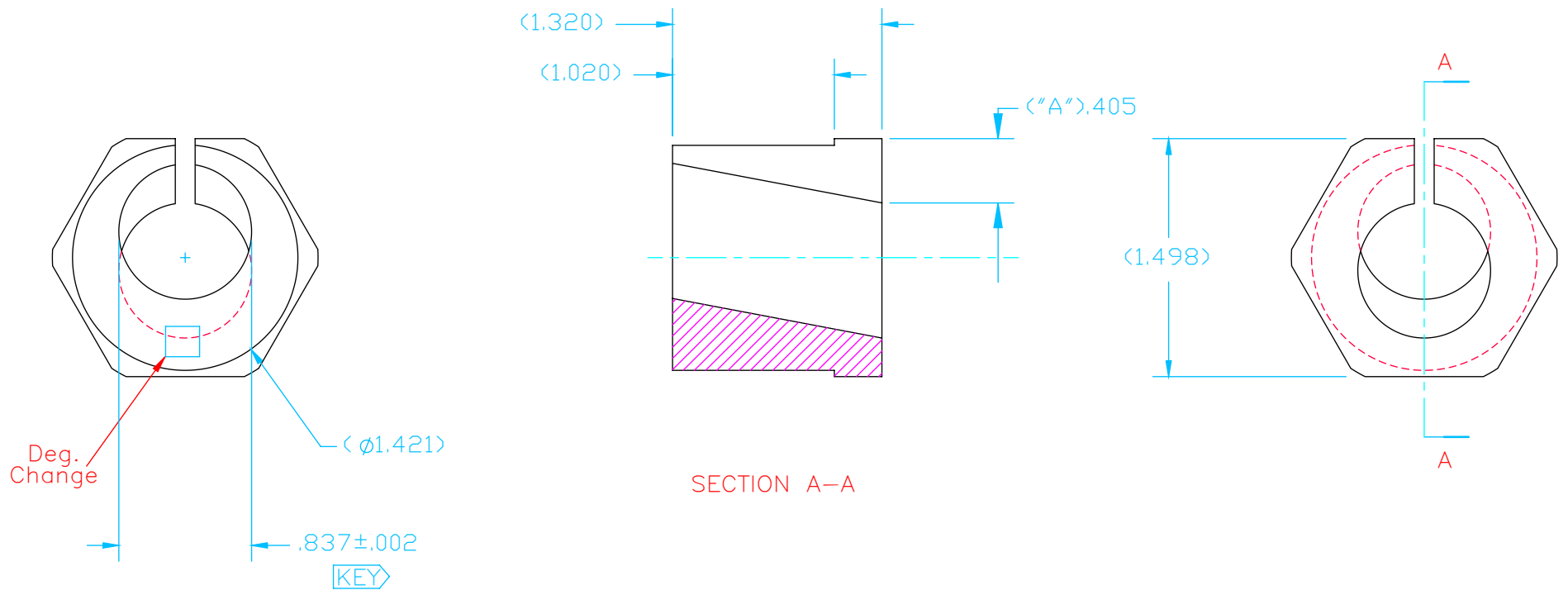

FINISH: CLEAR ZINC

SPECIALTY PRODUCTS COMPANY

231911-231941

BUSHING

SHEET 1 OF 1

REV. C

**FOR RECEIVING-INSPECTION USE**